



SERVICE MANUAL

MODEL : SB74

Stylish Powerful Portable Boom Box

SERVICE MANUAL

CAUTION

BEFORE SERVICING THE UNIT, READ THE "SAFETY PRECAUTIONS" IN THIS MANUAL.

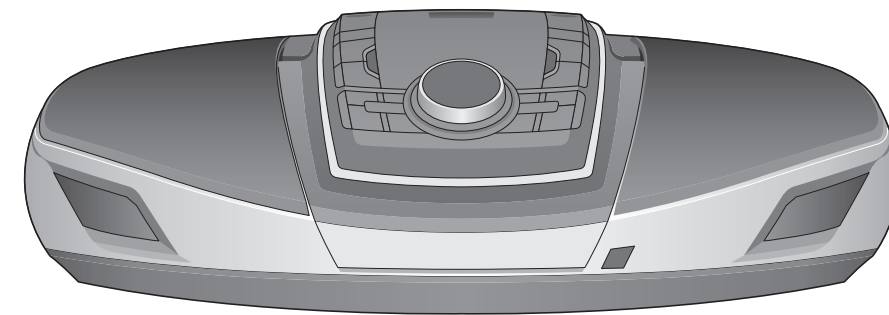

MODEL : SB74



[CONTENTS]

SECTION 1. GENERAL

- SERVICING PRECAUTIONS..... 1-2
- ESD PRECAUTIONS..... 1-4
- PROGRAM DOWNLOAD GUIDE..... 1-5
- SPECIFICATIONS 1-6

SECTION 2. EXPLODED VIEWS

- CABINET AND MAIN FRAME SECTION (SB74) 2-1
- PACKING ACCESSORY SECTION..... 2-5

SECTION 3. ELECTRICAL PART

- TROUBLESHOOTING GUIDE..... 3-1
- WAVEFORMS OF MAJOR CHECK POINT..... 3-9
- WIRING DIAGRAM 3-14
- BLOCK DIAGRAMS 3-15
- CIRCUIT DIAGRAMS..... 3-17
- CIRCUIT VOLTAGE CHART 3-27
- PRINTED CIRCUIT DIAGRAMS 3-29

SECTION 4. REPLACEMENT PARTS LIST 4-1

SECTION 1. GENERAL

SERVICING PRECAUTIONS

NOTES REGARDING HANDLING OF THE PICK-UP

1. Notes for transport and storage

- 1) The pick-up should always be left in its conductive bag until immediately prior to use.
- 2) The pick-up should never be subjected to external pressure or impact.

Storage in conductive bag

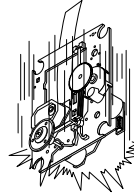
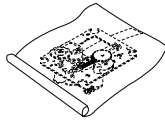

Drop impact

2. Repair notes

- 1) The pick-up incorporates a strong magnet, and so should never be brought close to magnetic materials.
- 2) The pick-up should always be handled correctly and carefully, taking care to avoid external pressure and impact. If it is subjected to strong pressure or impact, the result may be an operational malfunction and/or damage to the printed-circuit board.
- 3) Each and every pick-up is already individually adjusted to a high degree of precision, and for that reason the adjustment point and installation screws should absolutely never be touched.
- 4) Laser beams may damage the eyes!
Absolutely never permit laser beams to enter the eyes!
Also NEVER switch ON the power to the laser output part (lens, etc.) of the pick-up if it is damaged.

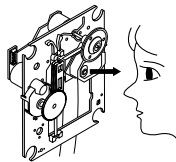

NEVER look directly at the laser beam, and don't allow contact fingers or other exposed skin.

5) Cleaning the lens surface

If there is dust on the lens surface, the dust should be cleaned away by using an air bush (such as used for camera lens). The lens is held by a delicate spring. When cleaning the lens surface, therefore, a cotton swab should be used, taking care not to distort this.

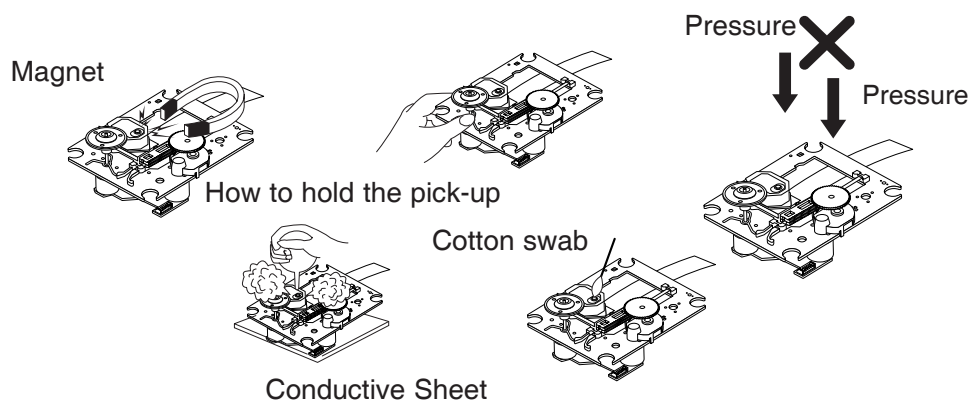

6) Never attempt to disassemble the pick-up.

Spring by excess pressure. If the lens is extremely dirty, apply isopropyl alcohol to the cotton swab. (Do not use any other liquid cleaners, because they will damage the lens.) Take care not to use too much of this alcohol on the swab, and do not allow the alcohol to get inside the pick-up.

NOTES REGARDING COMPACT DISC PLAYER REPAIRS

1. Preparations

- 1) Compact disc players incorporate a great many ICs as well as the pick-up (laser diode). These components are sensitive to, and easily affected by, static electricity. If such static electricity is high voltage, components can be damaged, and for that reason components should be handled with care.
- 2) The pick-up is composed of many optical components and other high-precision components. Care must be taken, therefore, to avoid repair or storage where the temperature of humidity is high, where strong magnetism is present, or where there is excessive dust.

2. Notes for repair

- 1) Before replacing a component part, first disconnect the power supply lead wire from the unit
- 2) All equipment, measuring instruments and tools must be grounded.
- 3) The workbench should be covered with a conductive sheet and grounded.
When removing the laser pick-up from its conductive bag, do not place the pick-up on the bag. (This is because there is the possibility of damage by static electricity.)
- 4) To prevent AC leakage, the metal part of the soldering iron should be grounded.
- 5) Workers should be grounded by an armband (1 M Ω)
- 6) Care should be taken not to permit the laser pick-up to come in contact with clothing, in order to prevent static electricity changes in the clothing to escape from the armband.
- 7) The laser beam from the pick-up should NEVER be directly facing the eyes or bare skin.

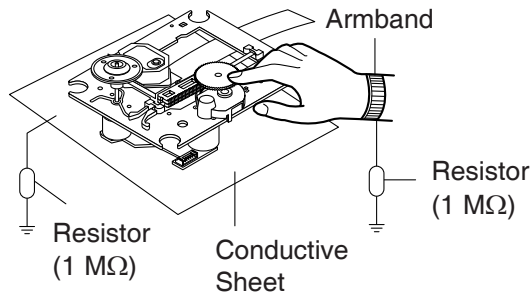

SAFETY PRECAUTIONS

Electrostatically Sensitive Devices (ESD)



Some semiconductor (solid state) devices can be damaged easily by static electricity. Such components commonly are called Electrostatically Sensitive Devices (ESD). Examples of typical ESD devices are integrated circuits and some field-effect transistors and semiconductor chip components. The following techniques should be used to help reduce the incidence of component damage caused by static electricity.

1. Immediately before handling any semiconductor component or semiconductor-equipped assembly, drain off any electrostatic charge on your body by touching a known earth ground. Alternatively, obtain and wear a commercially available discharging wrist strap device, which should be removed for potential shock reasons prior to applying power to the unit under test.
2. After removing an electrical assembly equipped with ESD devices, place the assembly on a conductive surface such as aluminum foil, to prevent electrostatic charge buildup or exposure of the assembly.
3. Use only a grounded-tip soldering iron to solder or unsolder ESD devices.
4. Use only an anti-static solder removal device. Some solder removal devices not classified as "anti-static" can generate electrical charges sufficient to damage ESD devices.
5. Do not use freon-propelled chemicals. These can generate electrical charges sufficient to damage ESD devices.
6. Do not remove a replacement ESD device from its protective package until immediately before you are ready to install it. (Most replacement ESD devices are packaged with leads electrically shorted together by conductive foam, aluminum foil or comparable conductive materials).
7. Immediately before removing the protective material from the leads of a replacement ESD device, touch the protective material to the chassis or circuit assembly into which the device will be installed.

CAUTION : BE SURE NO POWER IS APPLIED TO THE CHASSIS OR CIRCUIT, AND OBSERVE ALL OTHER SAFETY PRECAUTIONS.

8. Minimize bodily motions when handling unpackaged replacement ESD devices. (Otherwise harmless motion such as the brushing together of your clothes fabric or the lifting of your foot from a carpeted floor can generate static electricity sufficient to damage an ESD device).

CAUTION. GRAPHIC SYMBOLS

	THE LIGHTNING FLASH WITH APROWHEAD SYMBOL. WITHIN AN EQUILATERAL TRIANGLE, IS INTENDED TO ALERT THE SERVICE PERSONNEL TO THE PRESENCE OF UNINSULATED "DANGEROUS VOLTAGE" THAT MAY BE OF SUFFICIENT MAGNITUDE TO CONSTITUTE A RISK OF ELECTRIC SHOCK.
	THE EXCLAMATION POINT WITHIN AN EQUILATERAL TRIANGLE IS INTENDED TO ALERT THE SERVICE PERSONNEL TO THE PRESENCE OF IMPORTANT SAFETY INFORMATION IN SERVICE LITERATURE.

PROGRAM UPGRADE PROCESS

Important Notice : When upgrade the software running,

Do not shut down the power, it may damage the unit

1. Copy the software file into the USB flash, As the file name is [SB74_VXX.mcs]
2. Insert the USB flash into the USB host
3. Set Function to the USB position.

Appear onto the LCD

CHECKING UPGRADE SUCCESS

4. After finish, Un-plug the AC inlet about 2sec. Than connect the AC inlet source again.
5. Software upgrade completed.
6. You can check the software version.
7. At Power on mode, Press STOP button of the set and PLAY key of the RCU together
LCD shows SB74_VXX(version)

SPECIFICATIONS

GENERAL

Power supply	Refer to main label.
Power consumption	Refer to main label.
Net Weight	3.3 kg
External dimensions (W x H x D)	524 x 155 x 288 mm

CD

Laser	Semiconductor laser, wave length 780nm
Frequency response (Audio)	100Hz to 18KHz
Single to noise ratio	More than 55dB
Dynamic range (Audio)	More than 50dB

TUNER(FM)

Tuning range	87.5 ~ 108MHz
Intermediate Frequency	128KHz
Oscillator frequency	32.768KHz
Frequency response (Audio)	100 Hz ~ 10 KHz

PORTABLE IN

Out put Power	7.5 W + 7.5 W
In put sense	500 mV
Frequency response (Audio)	100 Hz ~ 18 KHz
Signal to Noise Ratio	More than 55dB

SPEAKER

Model	G-C40-55-8F-10W
Type	1 Way 1 Speaker
Impedance	8 Ω
Rfrequency Response	120 Hz ~ 20 KHz
Rated Input Power	8 W
Max. Input Power	10 W
Net Dimension (HxDxD)	42 x 102 x50 mm
Net Weight	240 g

Designs and specifications are subject to change without prior notice.

SECTION 2. EXPLODED VIEWS

• CABINET AND MAIN FRAME SECTION (SB74)

NOTES) THE EXCLAMATION POINT WITHIN AN EQUILATERAL TRIANGLE IS INTENDED TO ALERT THE SERVICE PERSONNEL TO THE PRESENCE OF IMPORTANT SAFETY INFORMATION IN SERVICE LITERATURE.

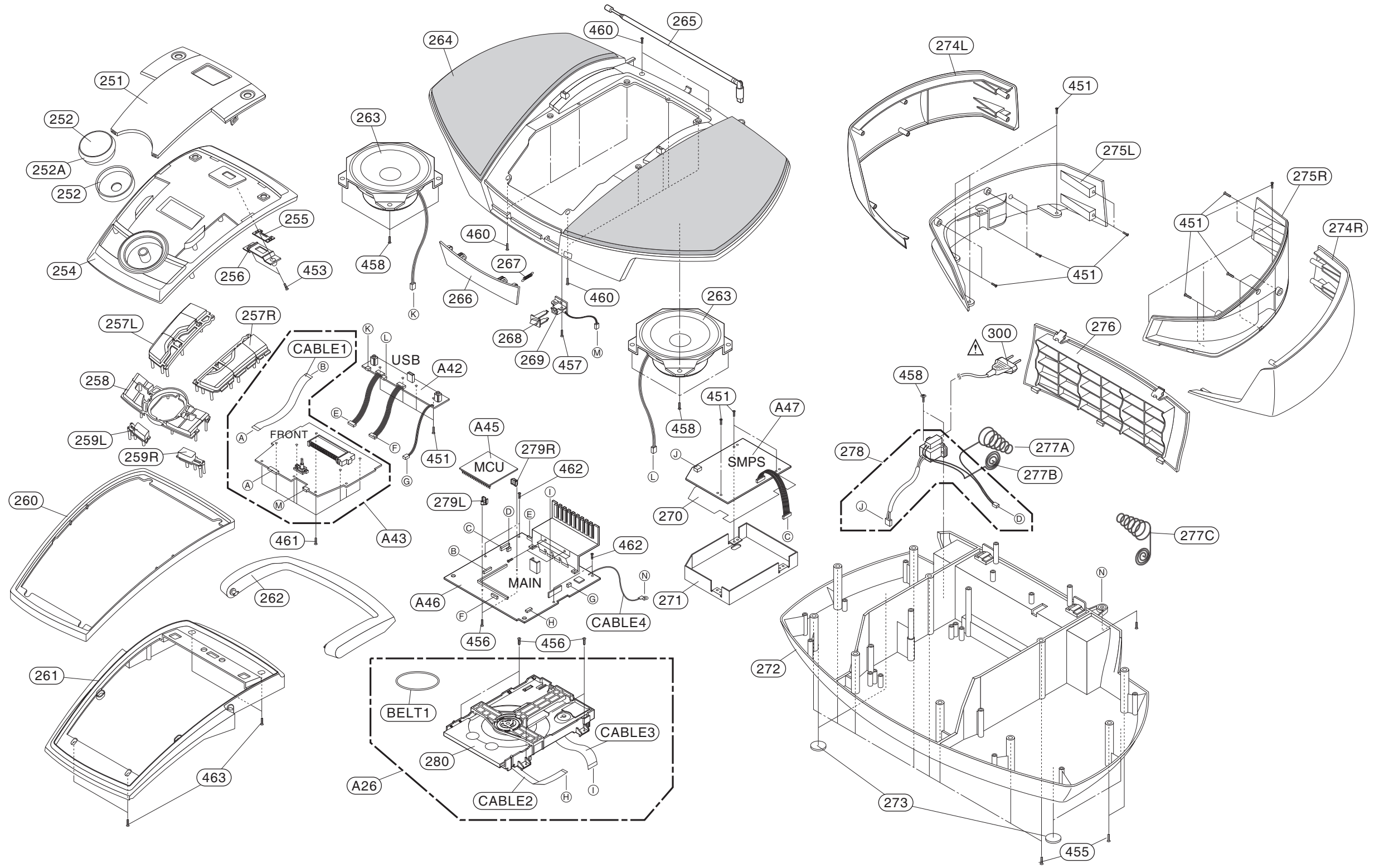

MEMO

Lined area for writing a memo on page 2-3.

MEMO

Lined area for writing a memo on page 2-4.

• PACKING ACCESSORY SECTION

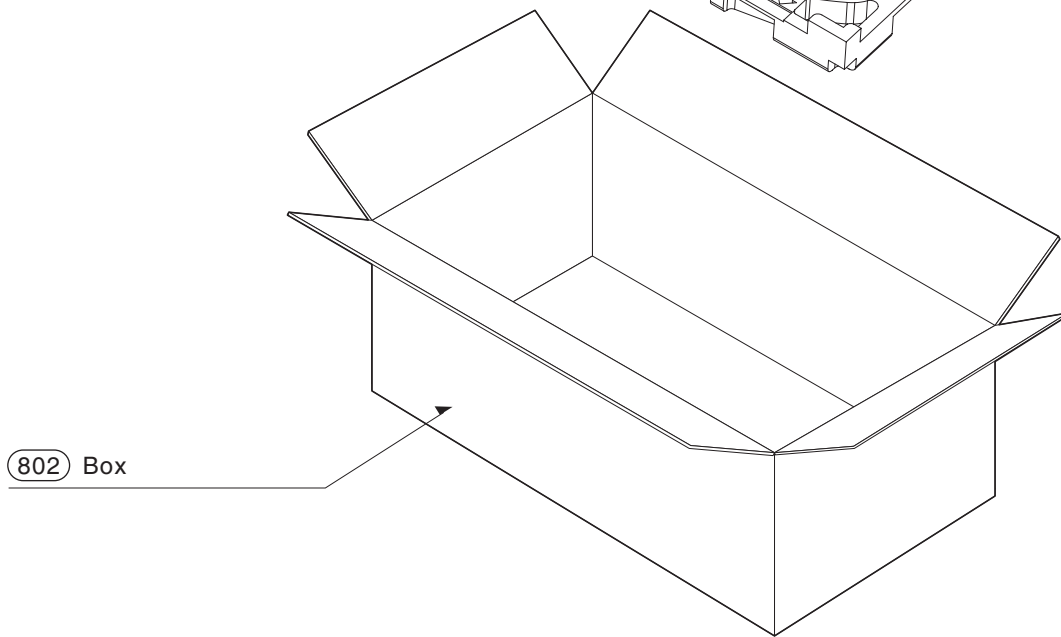
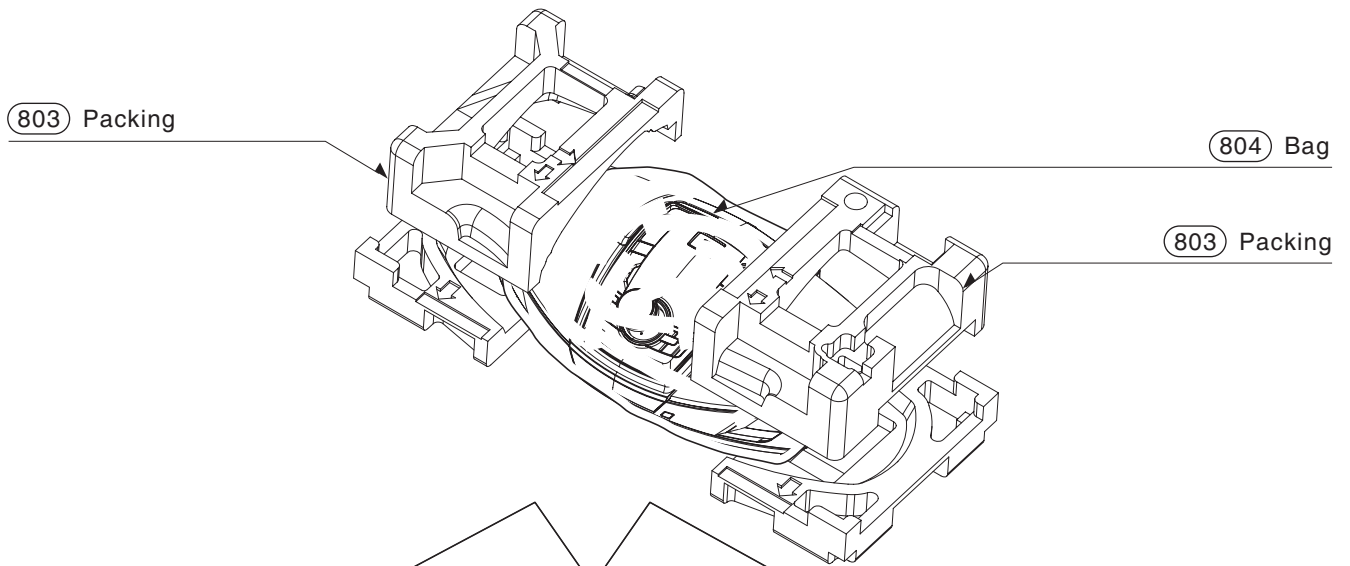
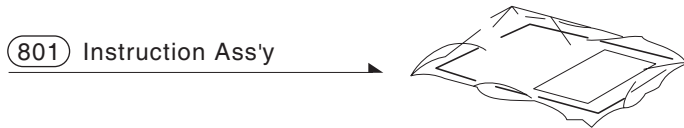

MEMO

A series of horizontal dotted lines for writing.

SECTION 3. ELECTRICAL PART

TROUBLESHOOTING GUIDE

1. SMPS PART

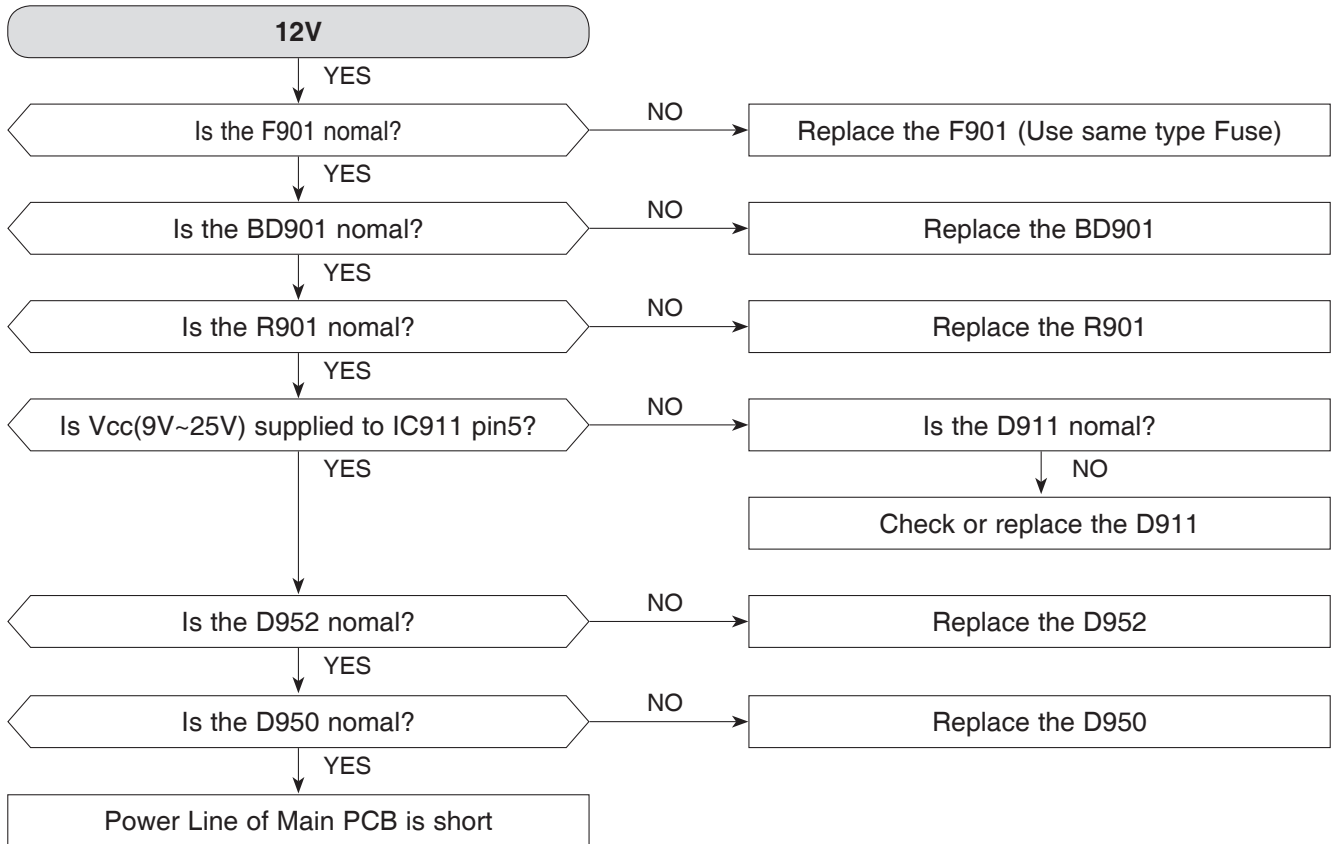

2. P-SENS PART

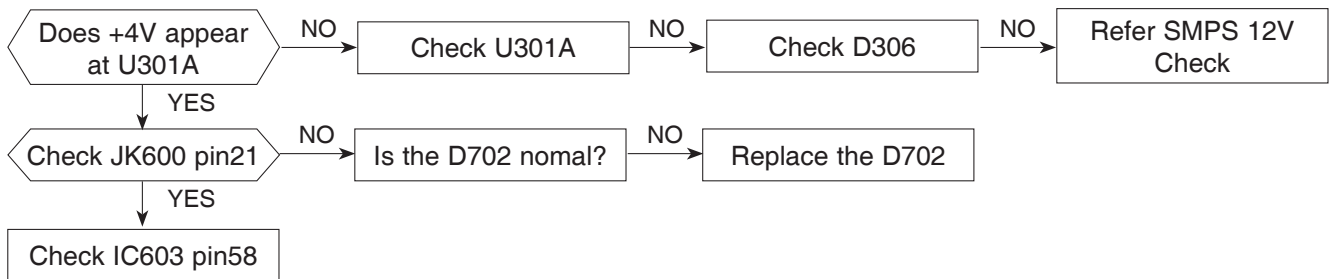

3. MUTING CIRCUIT (MUTE)

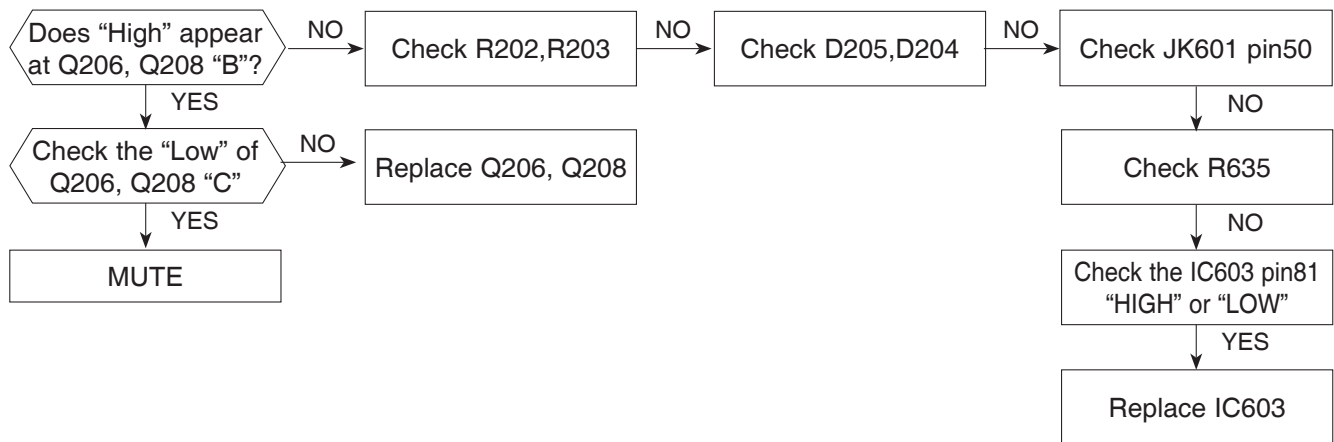

4. AUDIO ABNORMAL

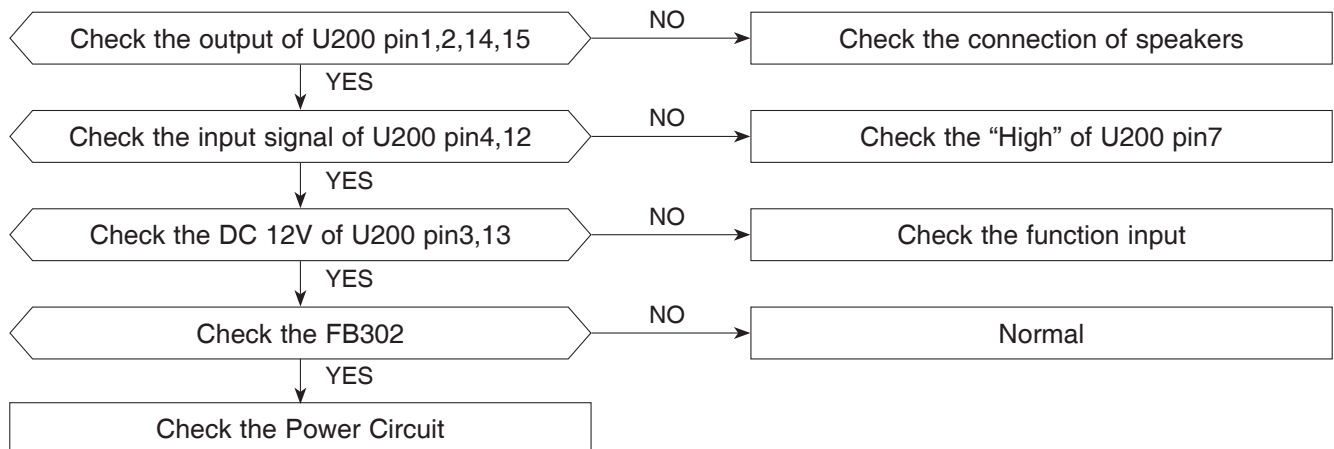

5. AUDIO ABNORMAL (FUNCTION MODE)

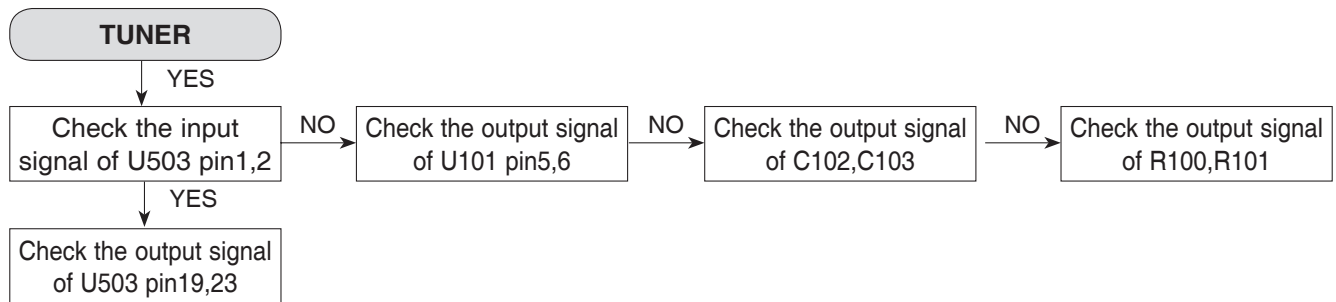
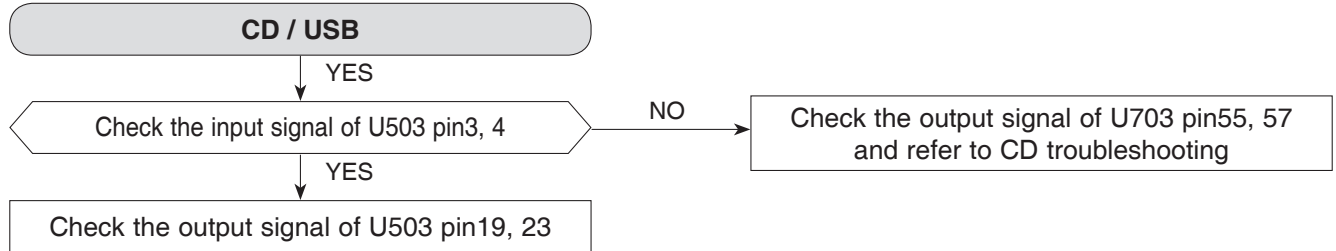
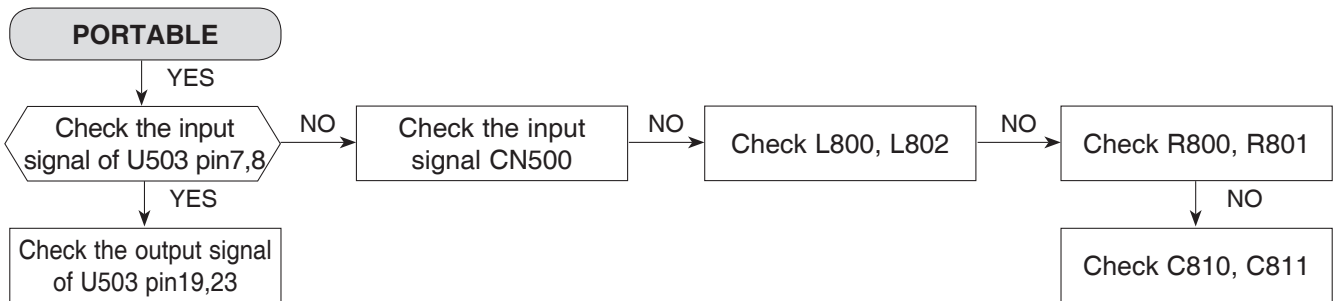

6. U302/3.3V ABNORMAL

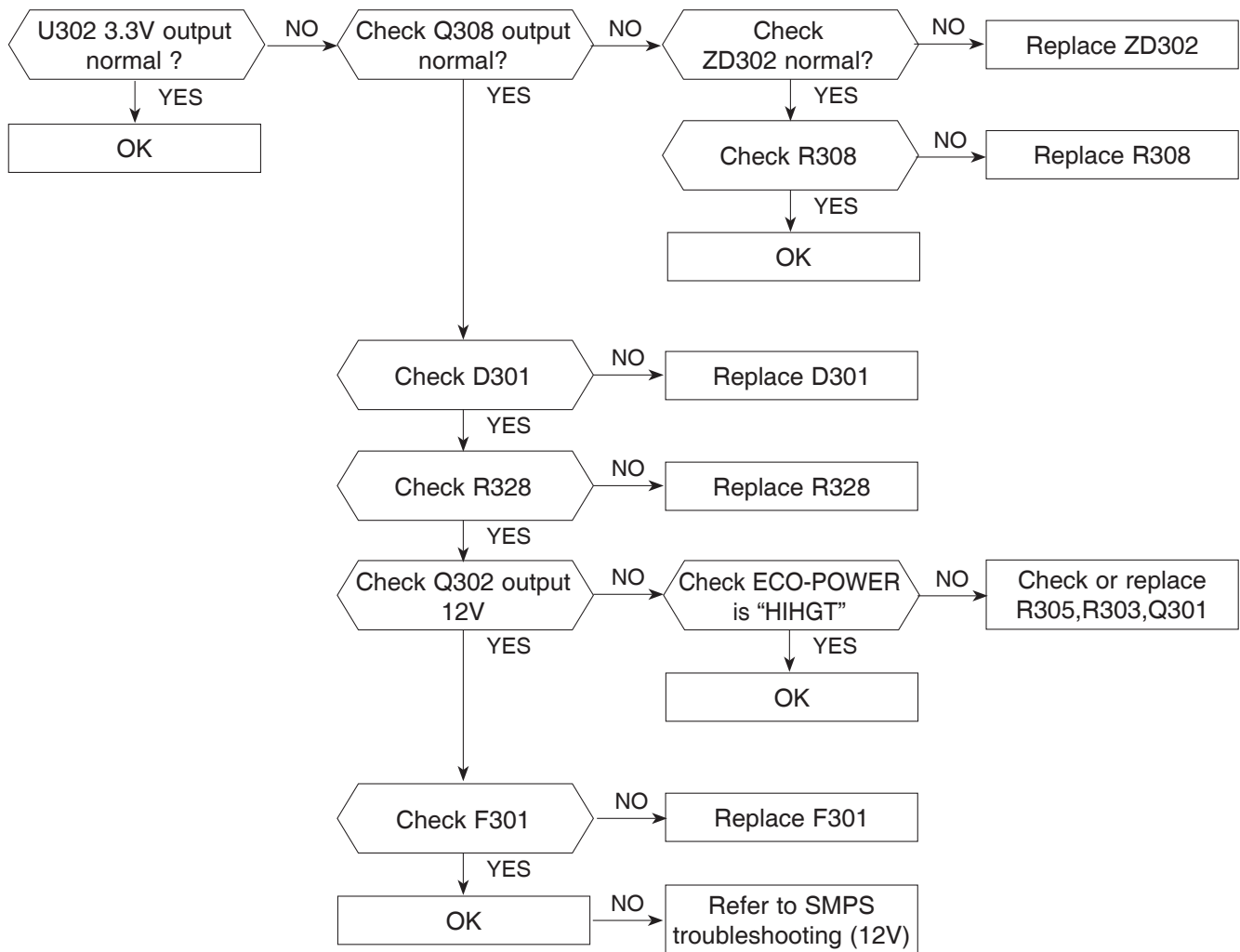

7. IC603 ABNORMAL

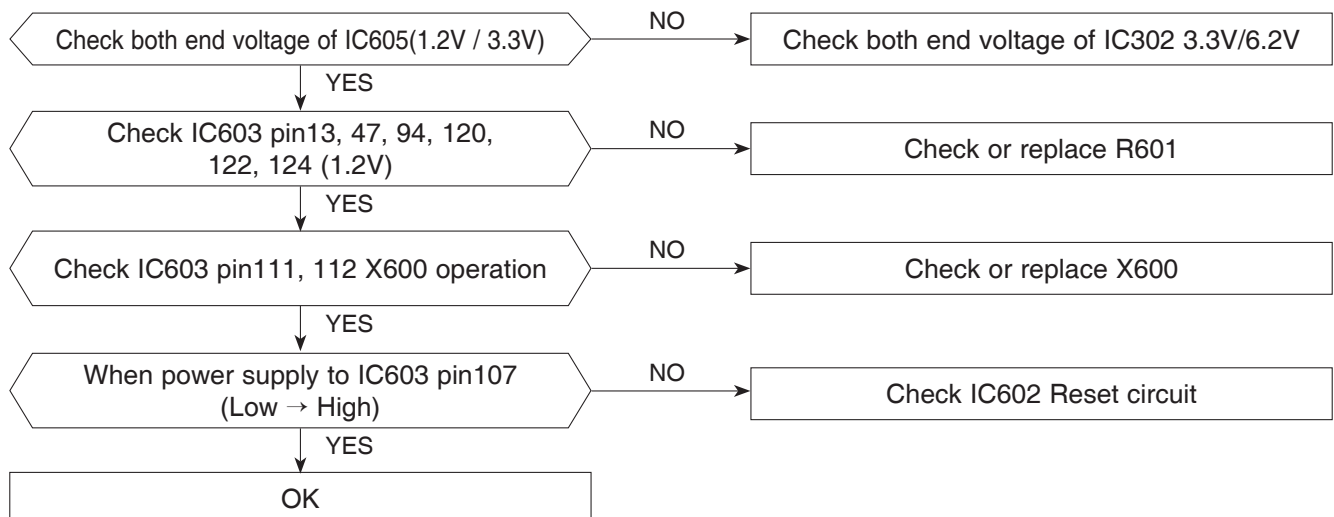

8. IC600 ABNORMAL

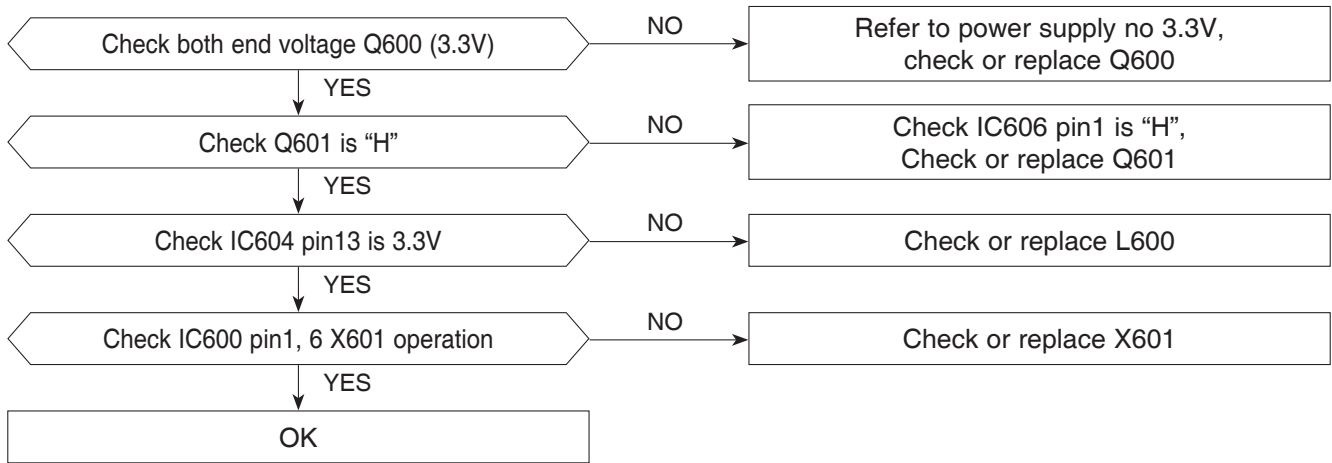

9. U654 ABNORMAL

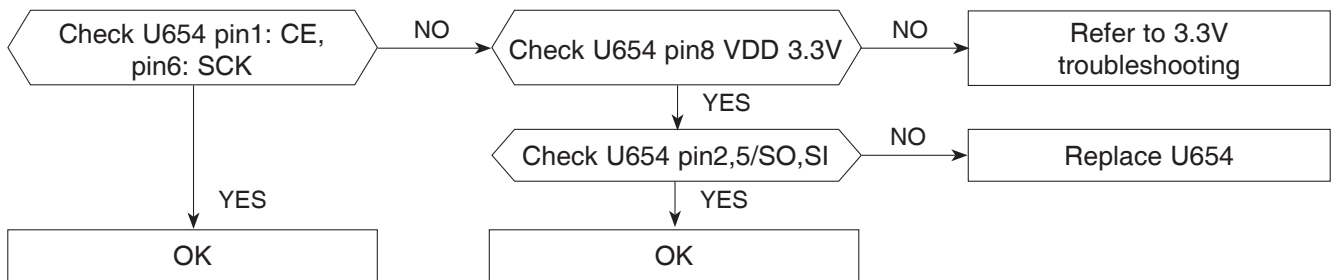

10. IC601 ABNORMAL

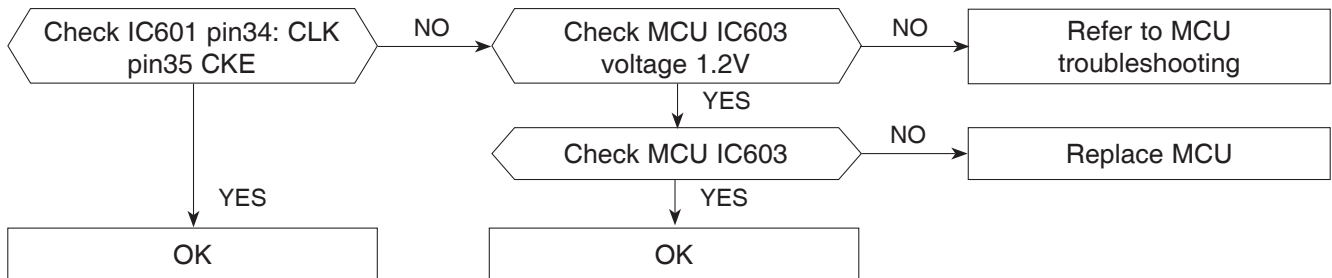

11. U503 ABNORMAL

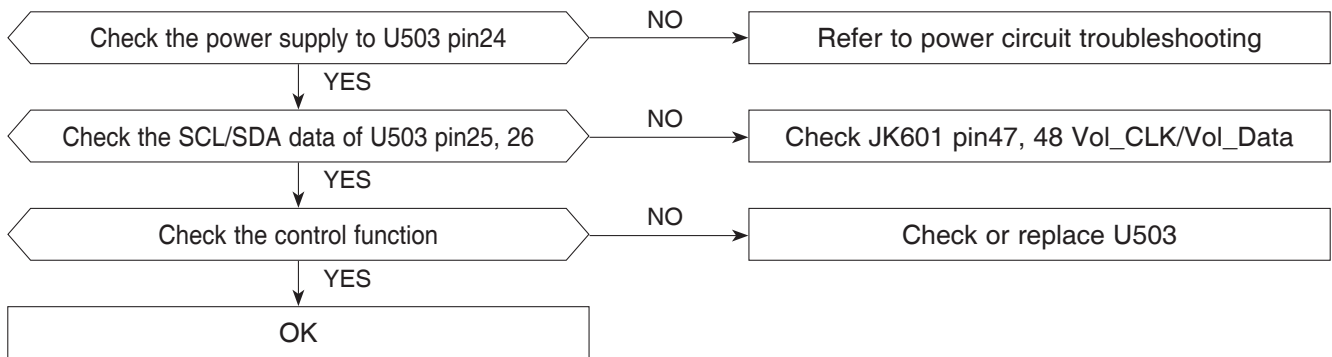

12. U501 ABNORMAL

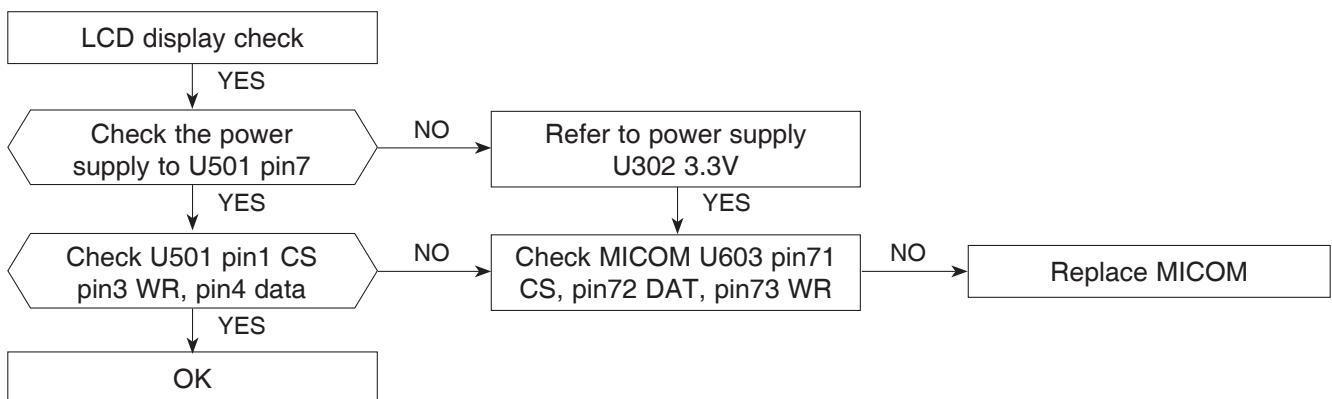

13. U101 FM TUNER MODULE

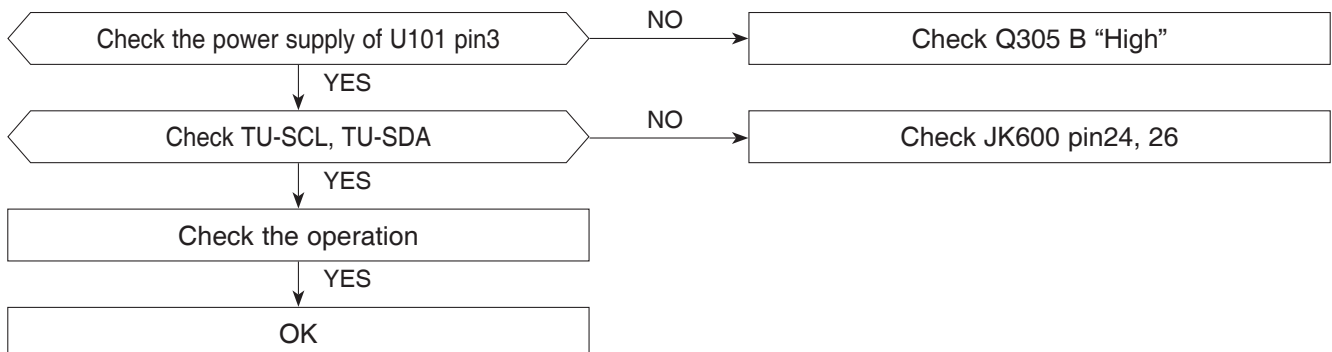

14. CD PART

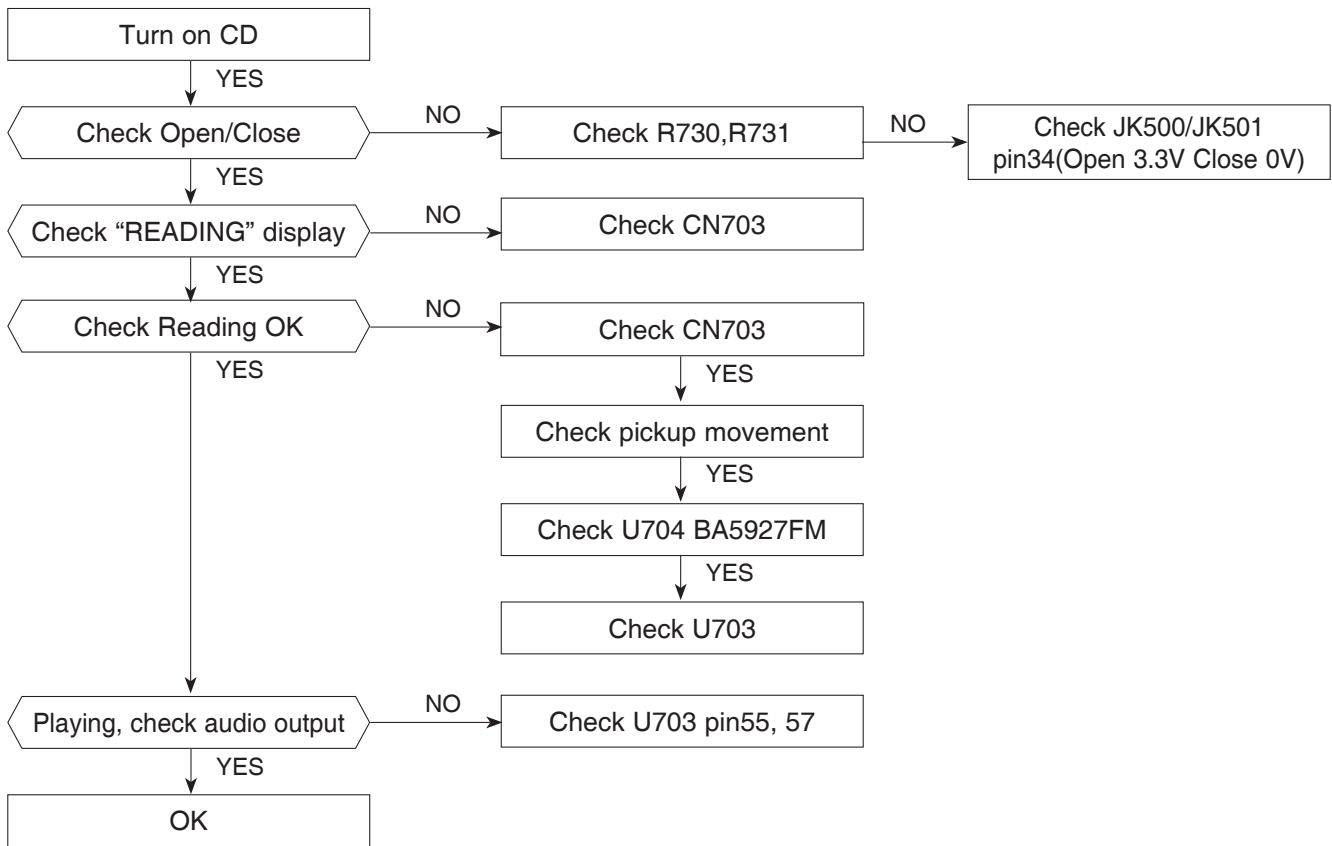

15. CD READING CHECK

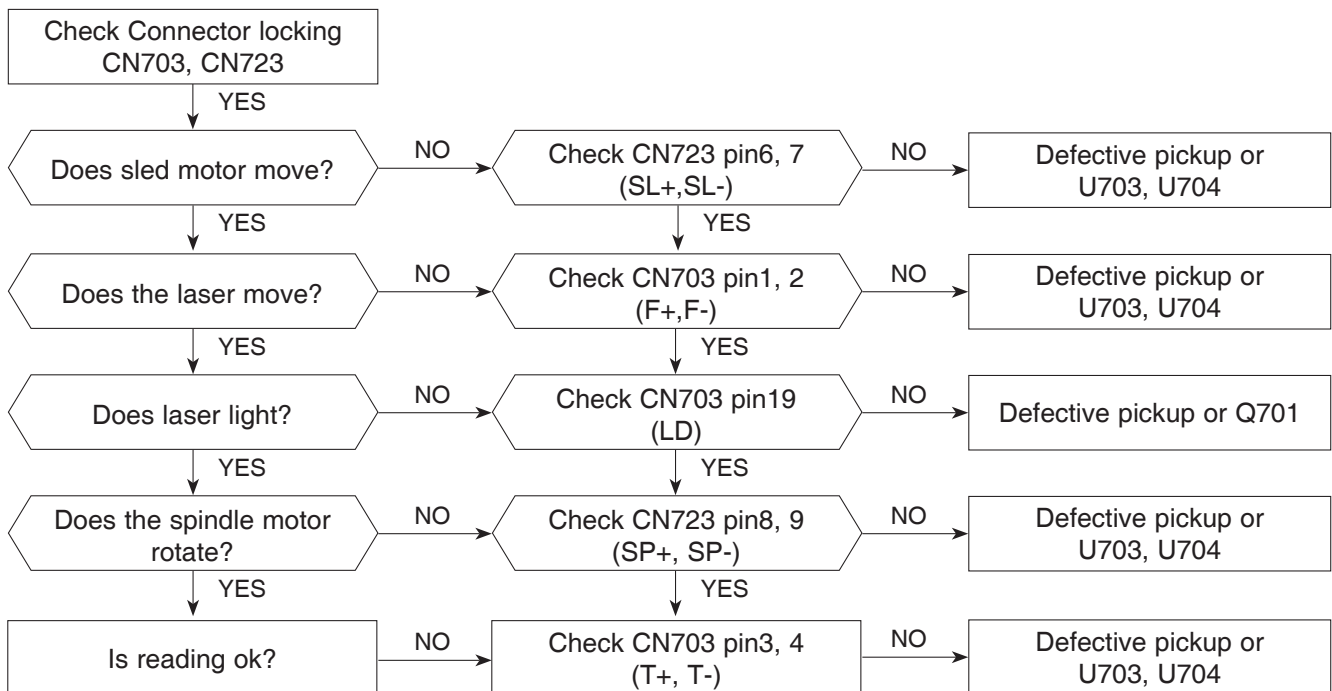

16. USB PART

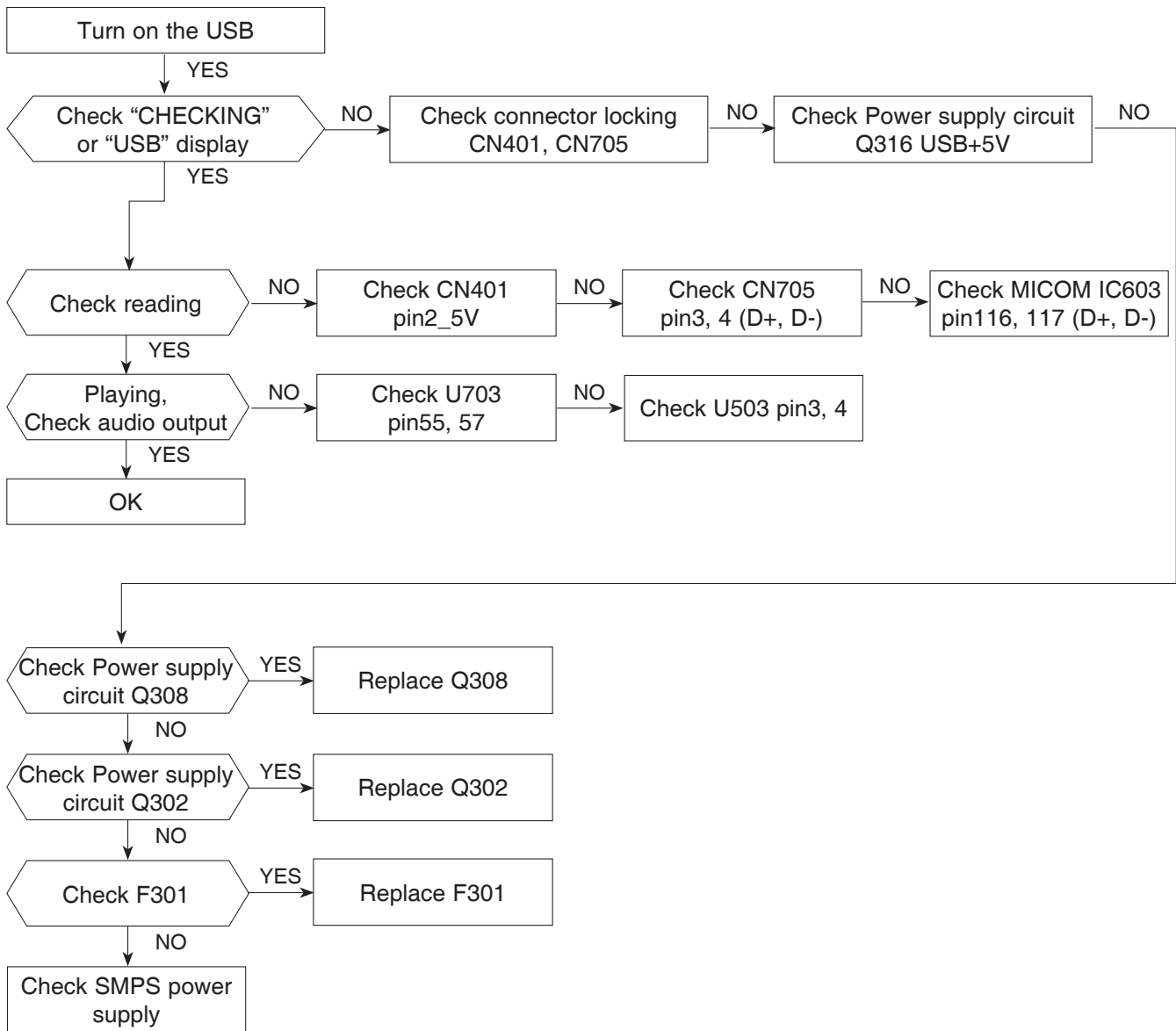

WAVEFORMS OF MAJOR CHECK POINT

1. SPINDLE DRIVE AND MOTOR WAVEFORM

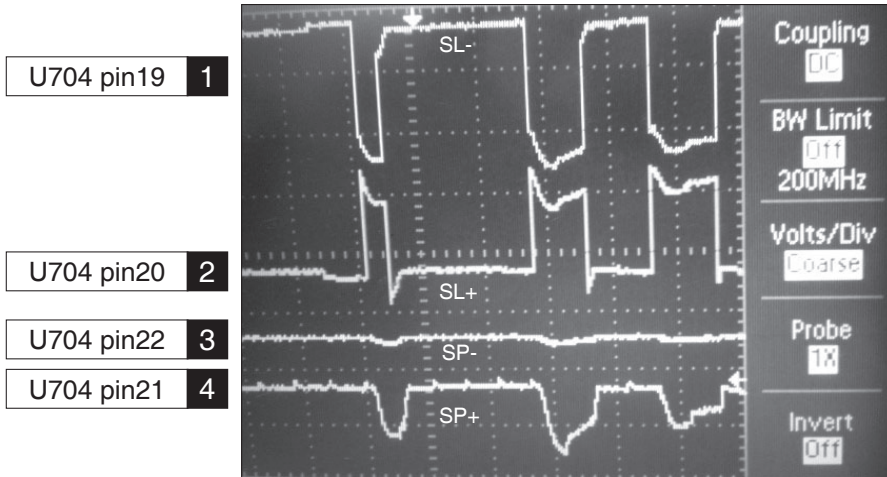

2. WHEN CD PLAYING FE/EE/TE/SP+ WAVEFORM

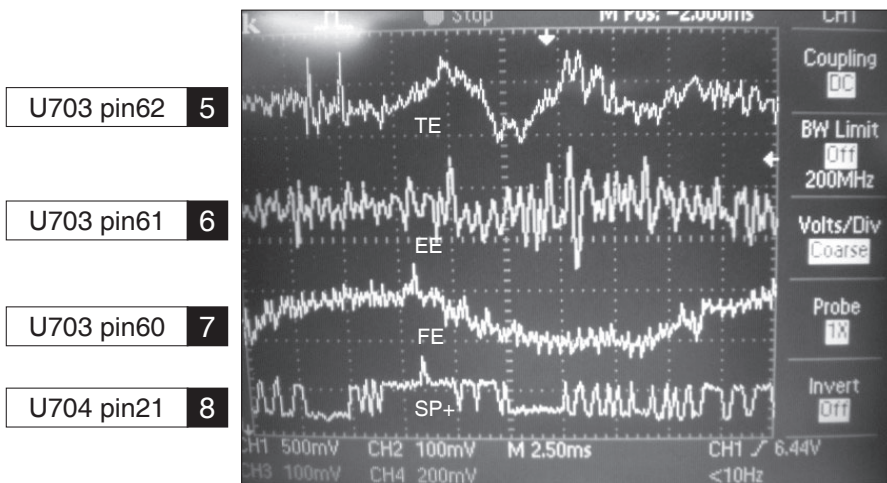

3. WHEN CD SEARCHING EE/TE/FE WAVEFORM

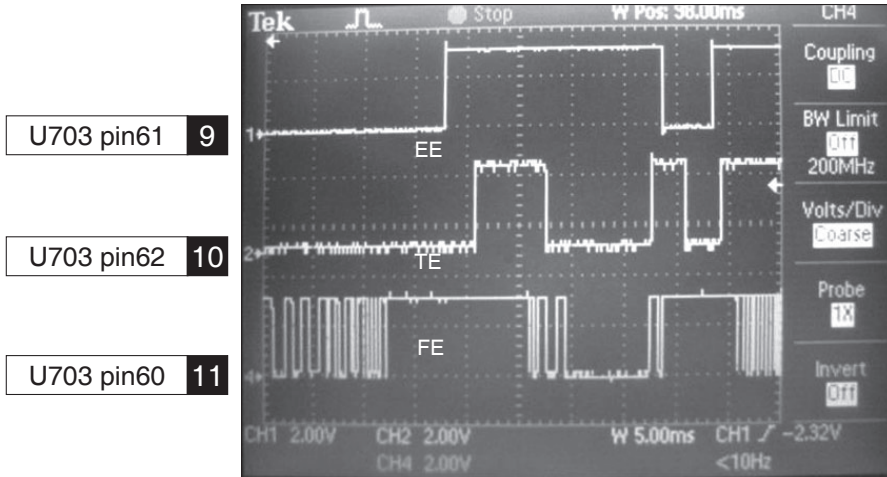

4. WHEN CD PLAYING FD/TD WAVEFORM

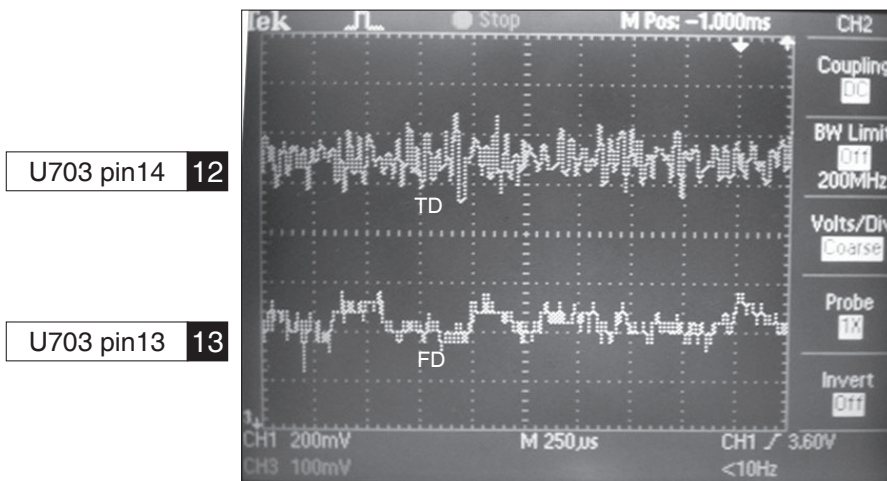

5. CD STOP ACTION SLE+/SP+/T+/F+ WAVEFORM

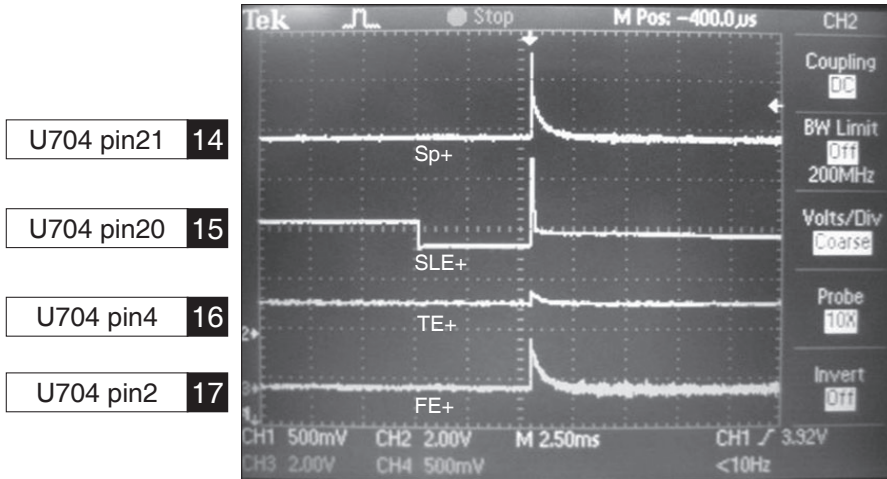

6. CD READING CD-MCK/DIN/RW/BUSY WAVEFORM

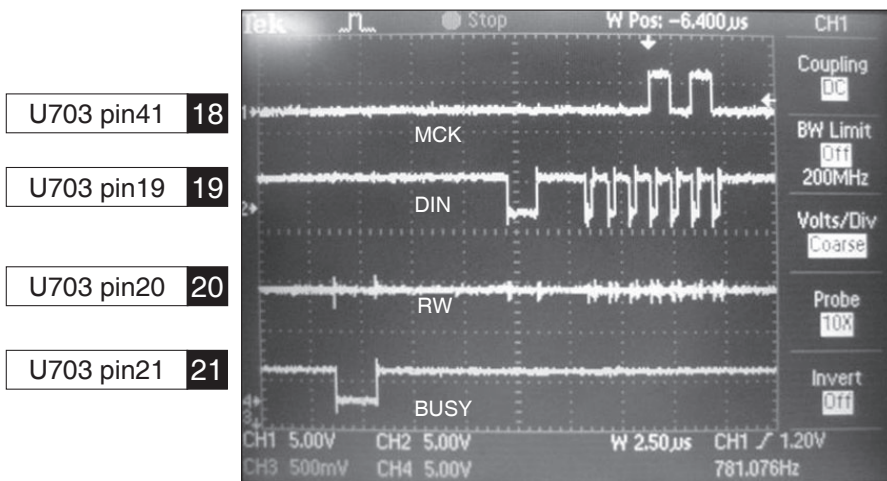

7. WHEN CD PLAYING RF WAVEFORM

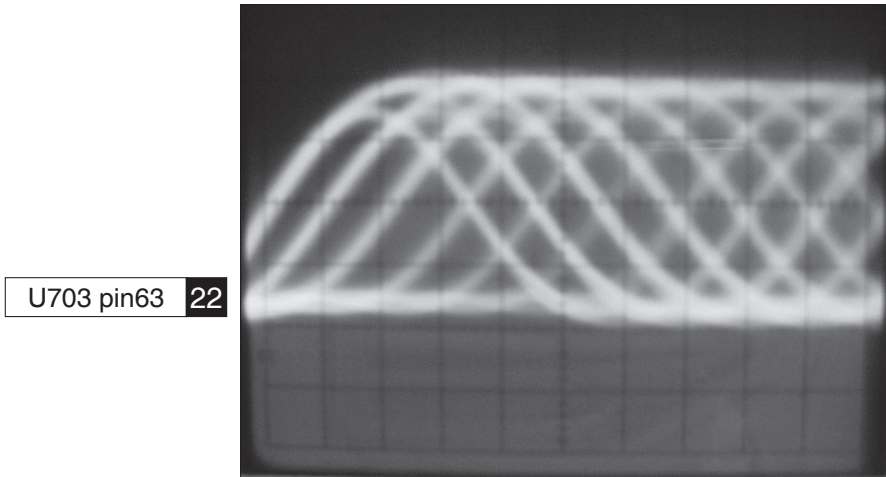

8. CD READING DAC-LRCK/BCK/MCK/DATA WAVEFORM

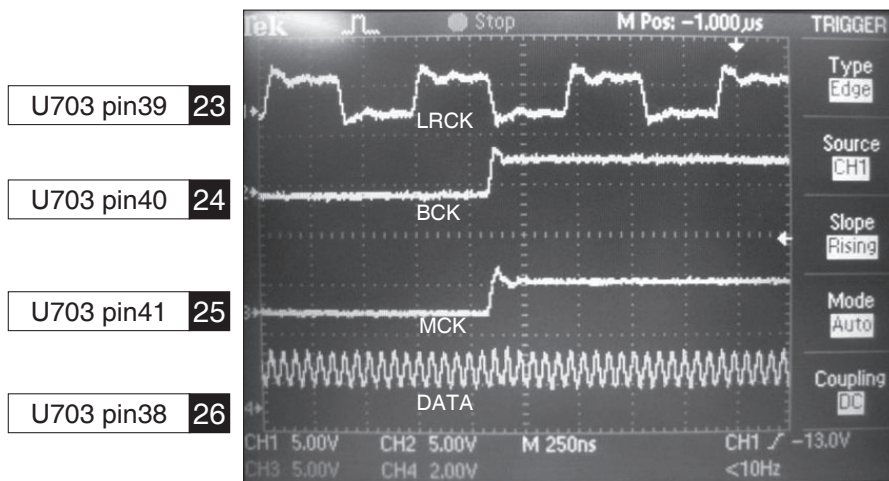

9. WHEN USB OPERATING D-/+5V/D+ WAVEFORM

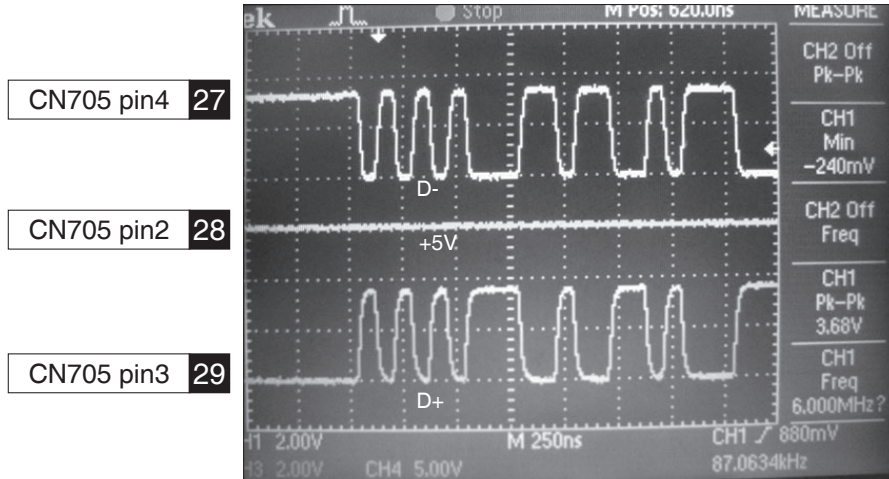

10. RADIO OPERATING TU-DA/CLK/RST WAVEFORM

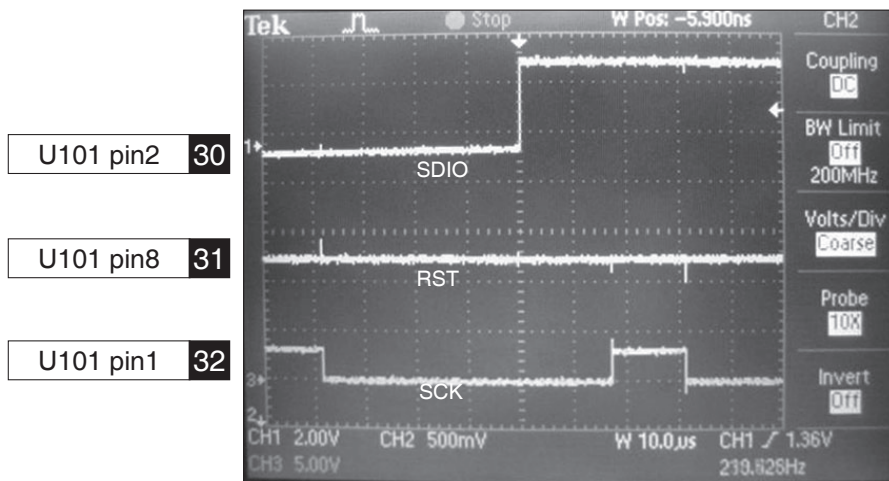

WIRING DIAGRAM

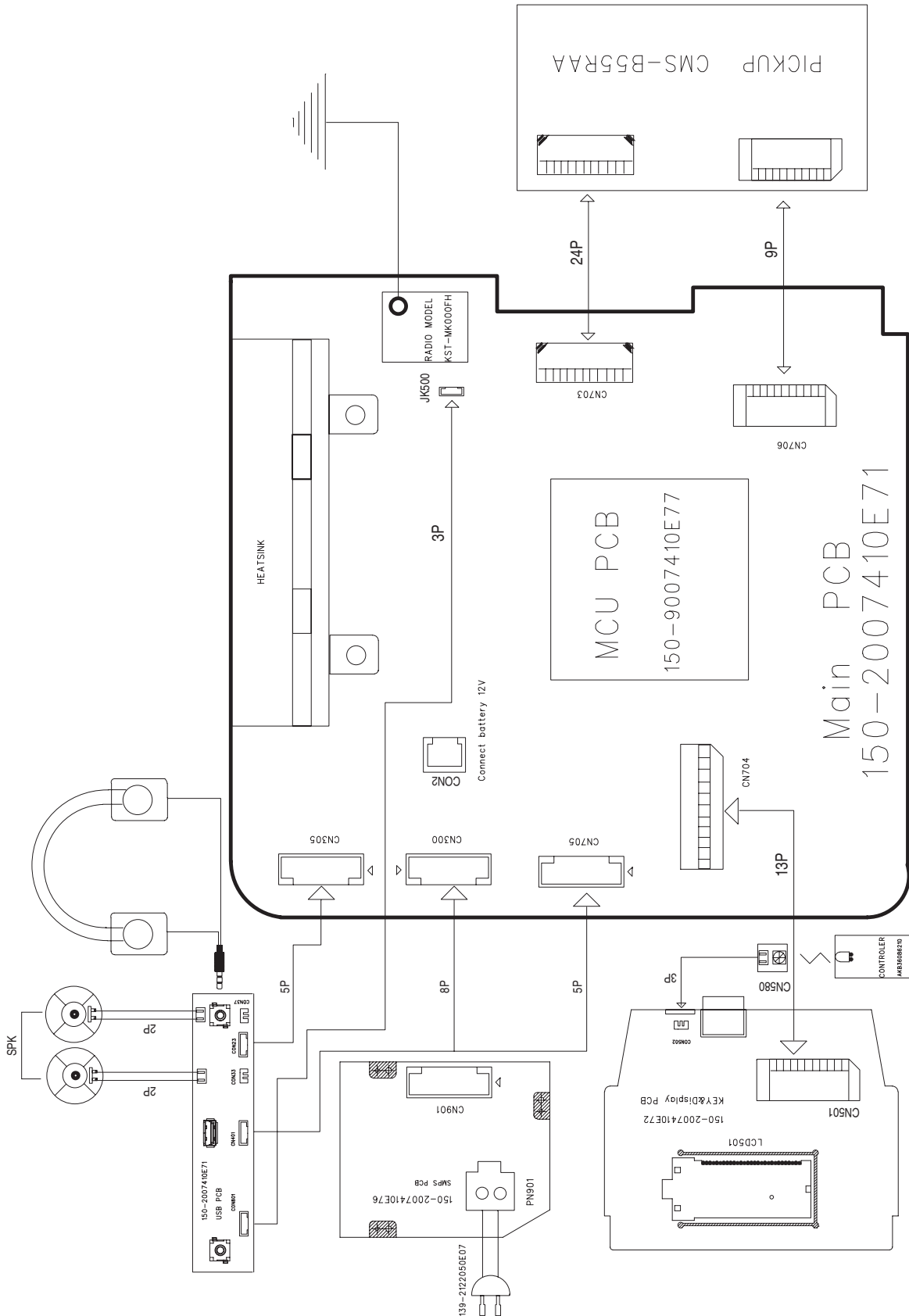

BLOCK DIAGRAM

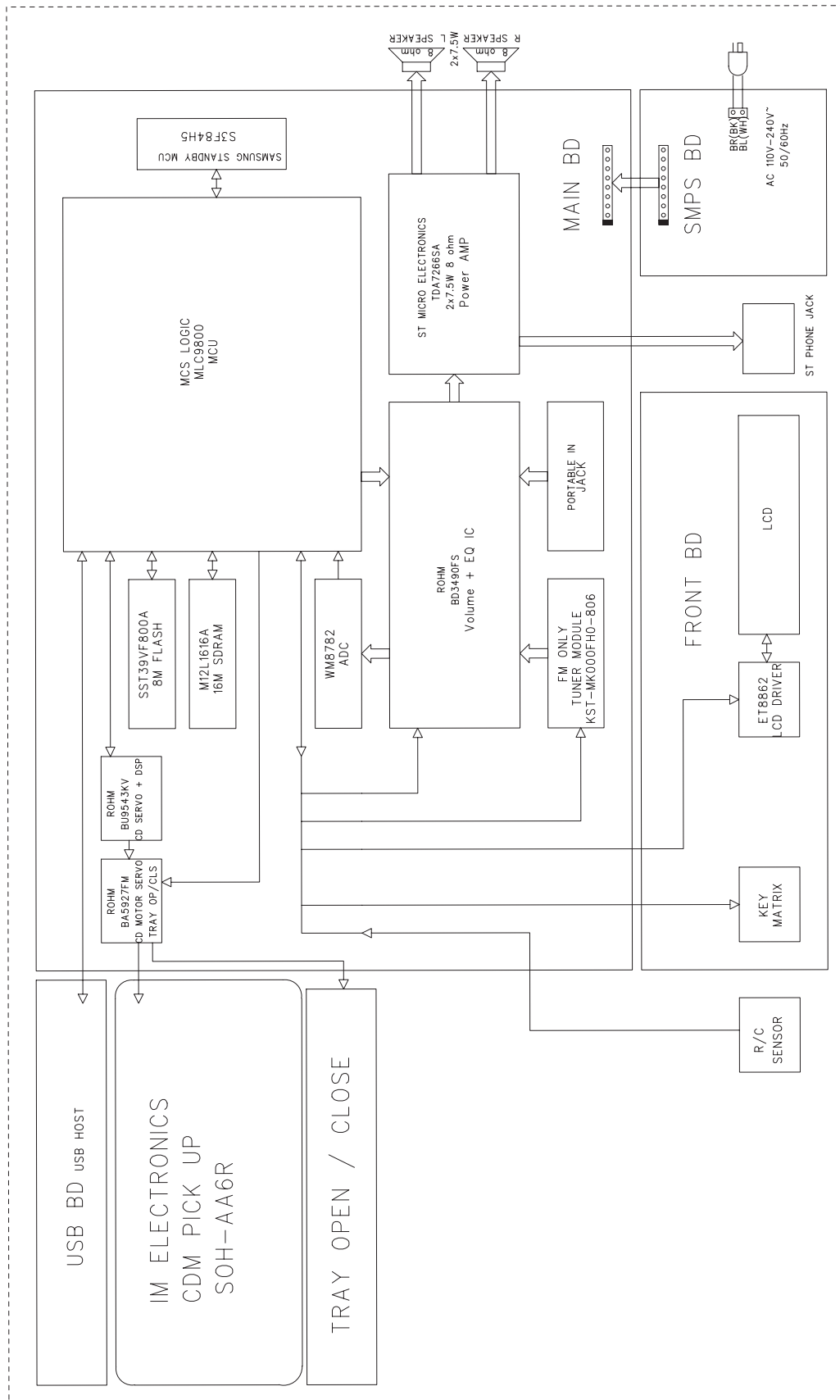

MEMO

A series of horizontal dotted lines for writing.

CIRCUIT DIAGRAMS

1. SMPS(POWER) CIRCUIT DIAGRAM

IMPORTANT SAFETY NOTICE

WHEN SERVICING THIS CHASSIS, UNDER NO CIRCUMSTANCES SHOULD THE ORIGINAL DESIGN BE MODIFIED OR ALTERED WITH OUT PERMISSION FROM THE LG CORPORATION. ALL COMPONENTS SHOULD BE REPLACED ONLY WITH TYPES IDENTICAL TO THOSE IN THE ORIGINAL CIRCUIT.

SPECIAL COMPONENTS ARE SHADED ON THE SCHEMATIC FOR EASY IDENTIFICATION. THIS CIRCUIT DIAGRAM MAY OCCASIONALLY DIFFER FROM THE ACTUAL CIRCUIT USED. THIS WAY, IMPLEMENTATION OF THE LATEST SAFETY AND PERFORMANCE IMPROVEMENT CHANGES INTO THE SET IS NOT DELAYED UNTIL THE NEW SERVICE LITERATURE IS PRINTED.

NOTE :

1. Shaded(■) parts are critical for safety. Replace only with specified part number.
2. Voltages are DC-measured with a digital voltmeter during Play mode.

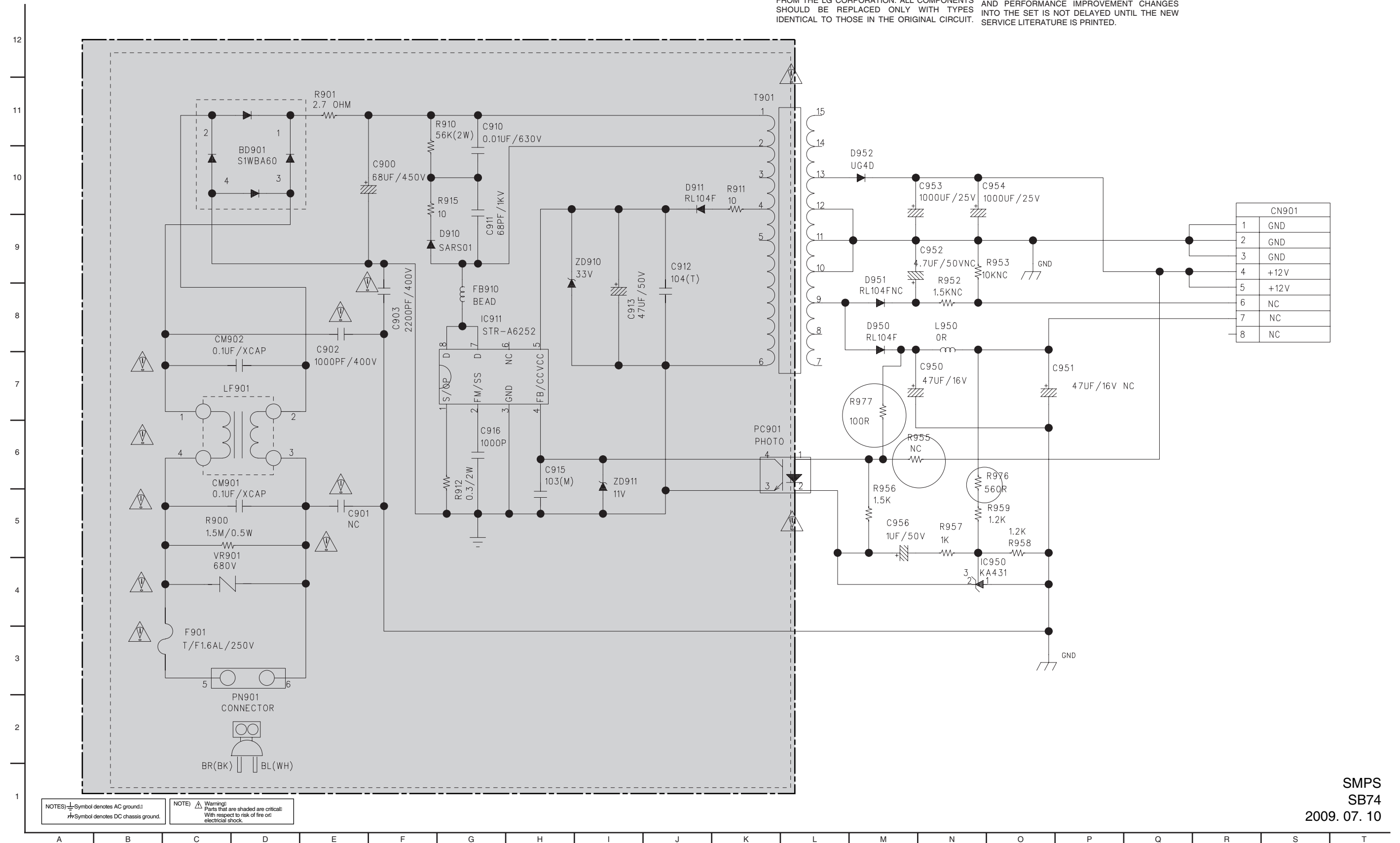

CN901	
1	GND
2	GND
3	GND
4	+12V
5	+12V
6	NC
7	NC
8	NC

NOTES) ⊥ Symbol denotes AC ground.
≡ Symbol denotes DC chassis ground.

NOTE) ⚠ Warning!
Parts that are shaded are critical!
With respect to risk of fire or electrical shock.

SMPS
SB74
2009. 07. 10

2. MAIN CIRCUIT DIAGRAM

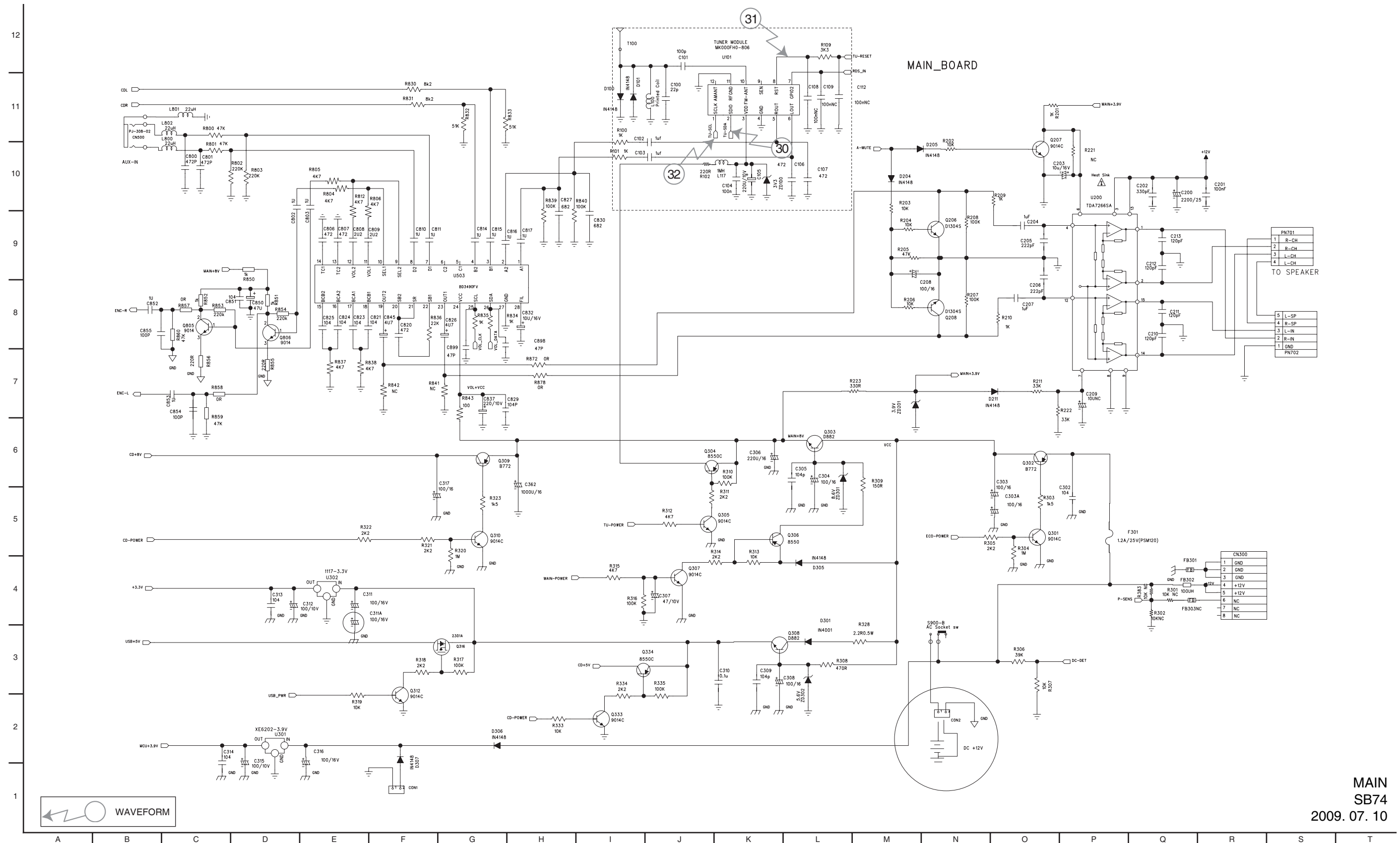

MAIN
SB74
2009. 07. 10

3. CD CIRCUIT DIAGRAM

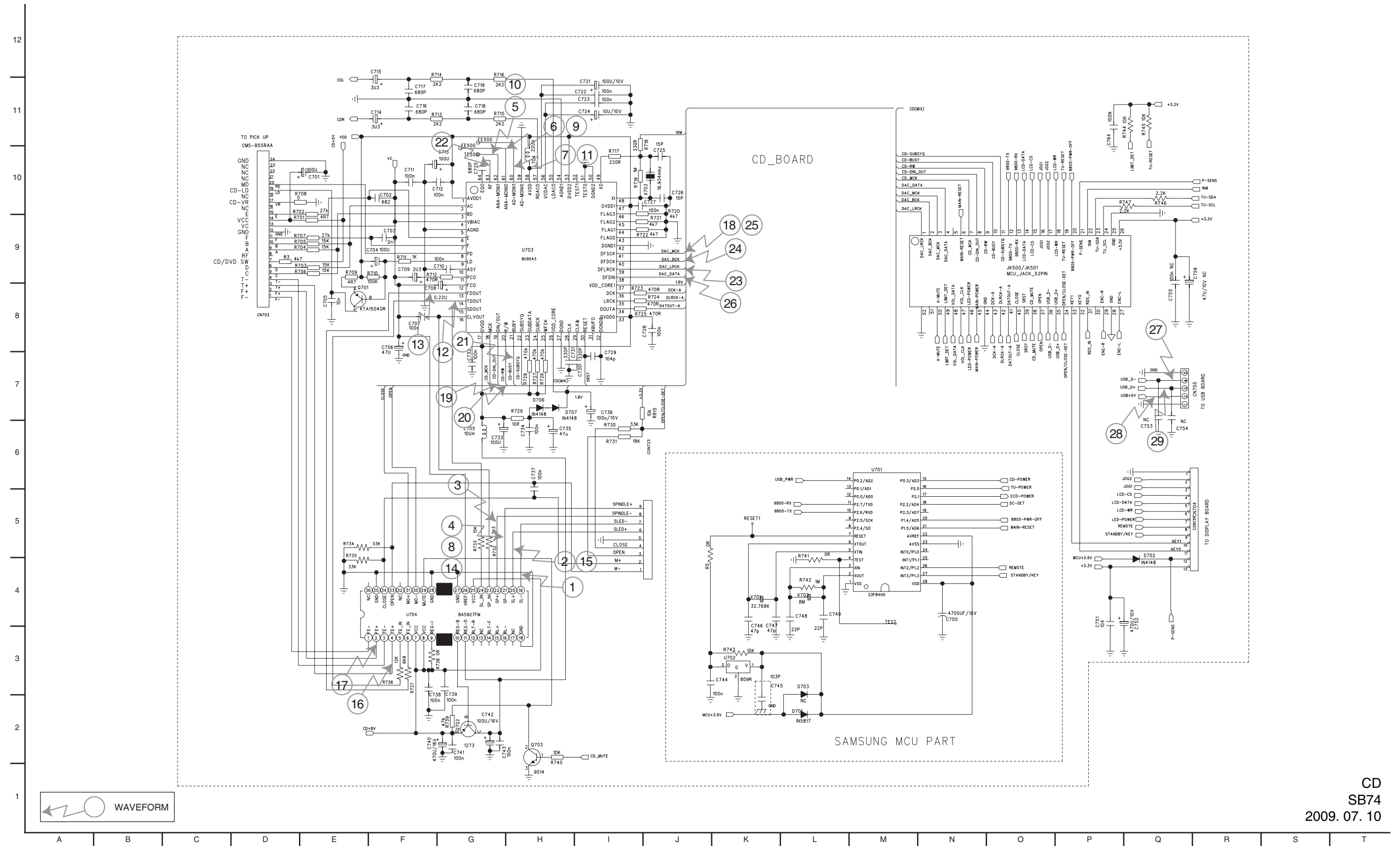

CD
SB74
2009. 07. 10

4. MCU9800 CIRCUIT DIAGRAM

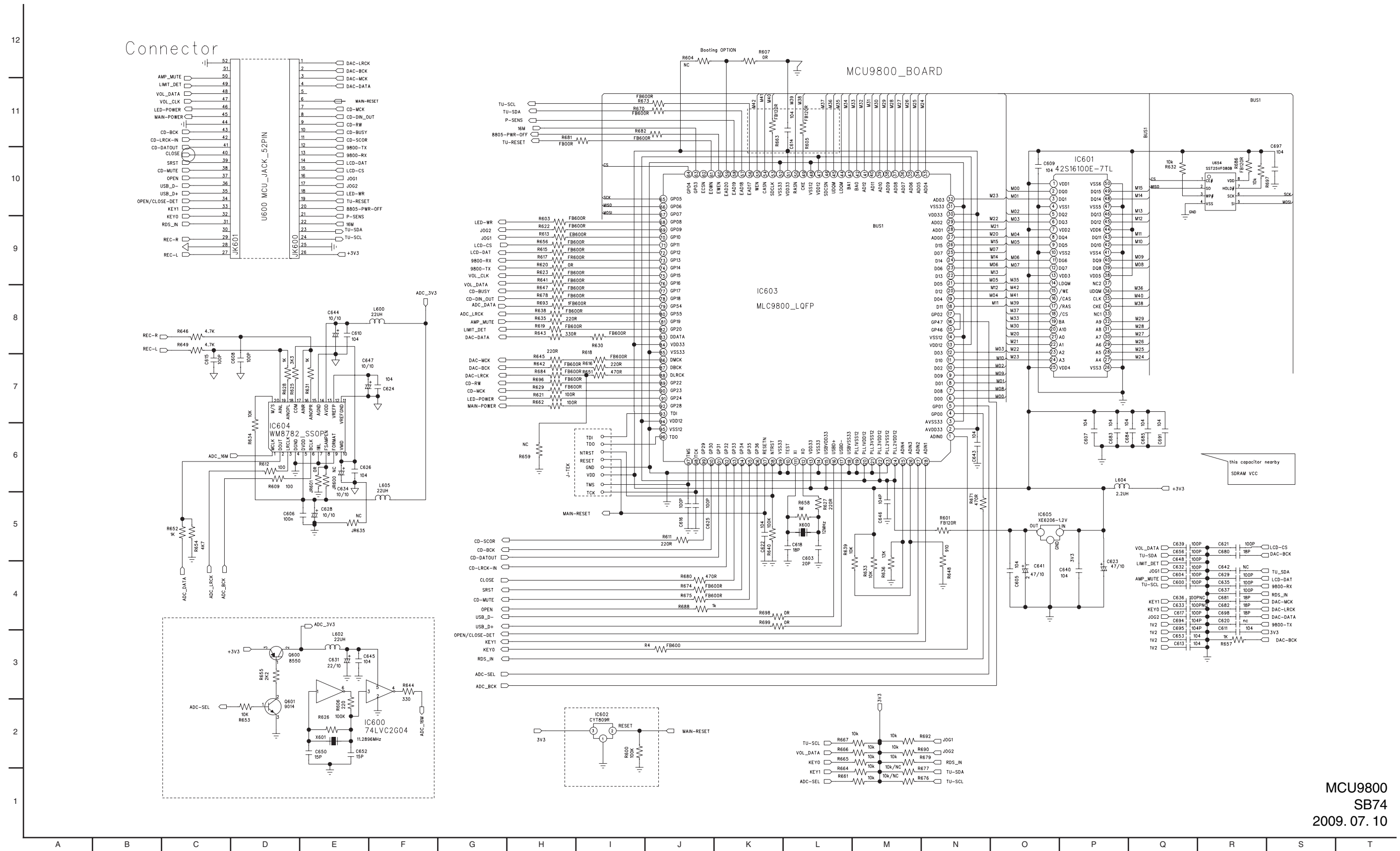

MCU9800
SB74
2009. 07. 10

5. LCD/USB/PH CIRCUIT DIAGRAM

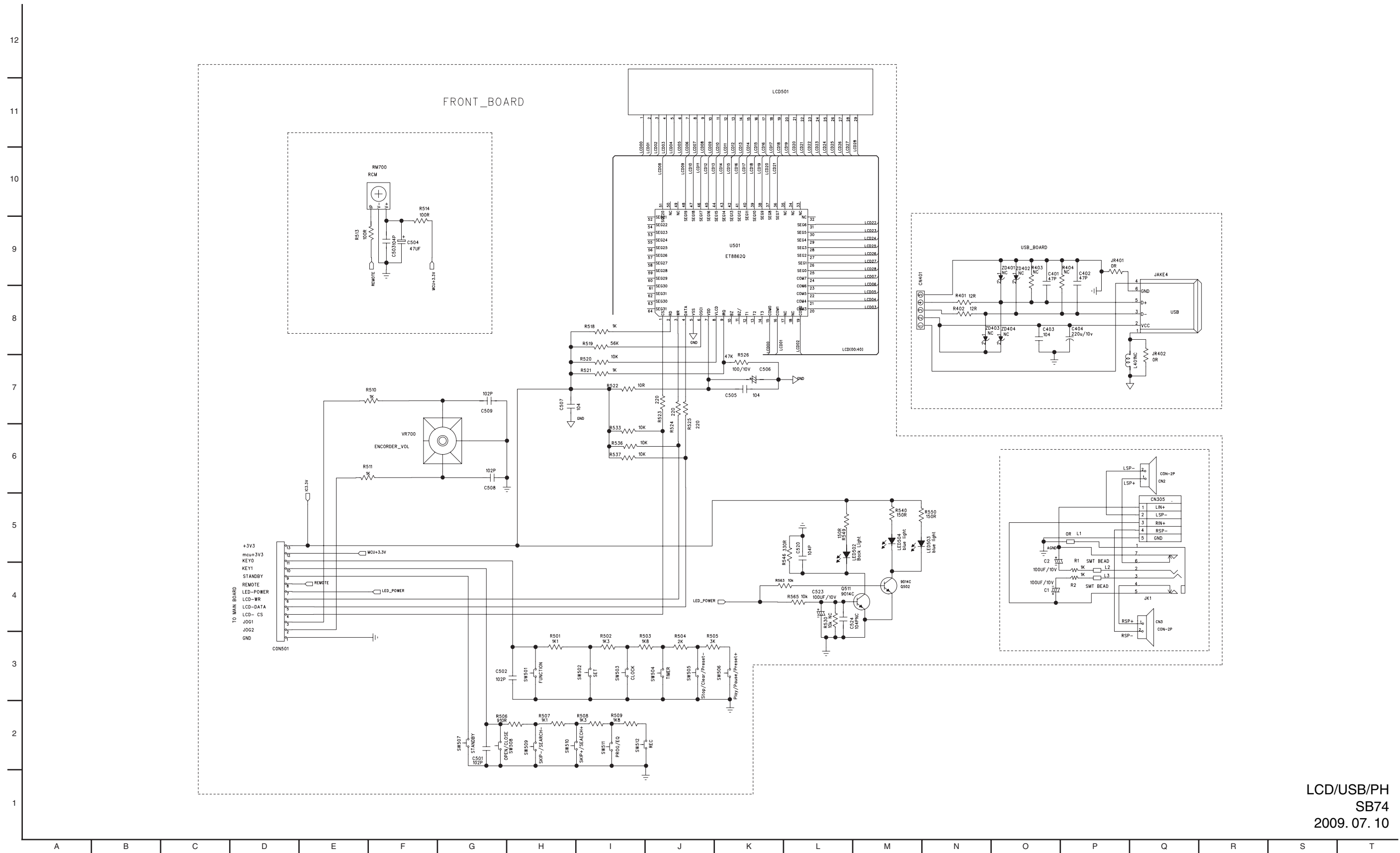

LCD/USB/PH
SB74
2009. 07. 10

CIRCUIT VOLTAGE CHART

Pin No.	Voltage
U501	
1	2.29
2	2.3
3	2.59
4	0.68
5	GND
6	3.3
7	3.3
8	2.99
9	3.23
10--14	NC
15	1.67
16	1.67
17	NC
18	NC
19--22	1.67
23	NC
24	NC
25--31	1.66
32--35	NC
36--48	1.66
51	1.66
49	NC
50	NC
52-61	1.66
62	NC
63	NC
64	NC
IC600	
1	1.25
2	GND
3	2.35
4	0.09
5	3.31
6	1.96
IC601	
1	3.25
2	2.12
3	2.12
4	DGND
5	2.12
6	2.12
7	3.25
8	2.12
9	2.12
10	DGND
11	2.15
12	2.15
13	3.25
14	0.9
15	1.53
16	2.93
17	3.09
18	0.9
19	0.9
20	0.9
21	0.9
22	0.9
23	0.9
24	0.9
25	3.25
26	DGND

Pin No.	Voltage
27	0.9
28	0.9
29	0.9
30	0.9
31	0.9
32	0.9
33	NC
34	0.9
35	1.53
36	0.9
37	NC
38	3.25
39	2.12
40	2.12
41	DGND
42	2.15
43	2.15
44	3.25
45	2.15
46	2.15
47	DGND
48	2.15
49	2.15
50	DGND
IC603	
1	3.25
2	3.25
3	AGND
4	3.25
5	3.2
6	2.12
7	2.12
8	2.12
9	2.12
10	2.12
11	2.12
12	2.12
13	1.2
14	AGND
15	0.38
16	3.1
17	0.38
18	2.15
19	2.15
20	2.15
21	2.15
22	2.15
23	2.15
24	2.15
25	2.15
26	2.15
27	2.15
28	0.89
29	0.89
30	3.25
31P	DGND
(32-46)	0.9
47	1.2
48	DGND
49	3.02
50	3.09
51	3.25

Pin No.	Voltage
52	DGND
53	1.53
54	1.53
55	2.93
56	2.93
57	2.93
58	3.25
59	3.25
60-62	3.25
63	1.36
64	2.12
65	2.68
66	0.01
67	1.31
68	0.01
69	3.18
70	0.28
71	3.21
72	0.47
73	3.21
74	3.24
75	3.25
76	3.25
77	3.3
78	2.12
79	0.01
80	0.02
81	3.16
82	2.76
83	1.64
84	3.25
85	DGND
86	1.65
87	0.77
88	1.06
89	1.59
90	3.2
91	1.24
92	1.24
93	2.14
94	1.3
95	DGND
96	2.1
97	1.8
98	1.33
99	0.08
100	1.61
101	1.6
102	1.67
103	0.05
104	9.4mV
105	3.25
106	9.4mV
107	3.26
108	0.05
109	DGND
110	DGND
111	1.55
112	1.35
113	3.3
114	DGND
115	3.3

Pin No.	Voltage
116	0.06
117	3.08
118	DGND
119	DGND
120	1.20V
121	DGND
122	1.20V
123	DGND
124	1.2
125	1.85
126	0.3
127	1.5
128	3.24
IC604	
1	0.02
2	0.02
3	0.05
4	DGND
5	3.3
6	0.03
7	DGND
8	3.28
9	DGND
10	0.04
11	GND
12	0.06
13	3.25
14	AGND
15	0.19
16	0.19
17	0.04
18	0.19
19	0.19
20	0.04
IC605	
1	GND
2	3.31
3	1.2
IC654	
1	3.25
2	0.01
3	2.12
4	DGND
5	1.31
6	2.68
7	2.12
8	3.25
U200	
1	7.74
2	7.75
3	15.52
4	1.49
5	NC
6	7.78
7	7.45
8	GND
9	GND
10	NC
11	NC
12	1.48
13	15.52
14	7.74

Pin No.	Voltage
15	7.75
U301A	
1	GND
2	11.45
3	3.96
U302	
1	GND
2	3.3
3	5.43
U503	
1	4.17
2	4.17
3	4.17
4	4.17
5	4.17
6	4.17
7	4.17
8	4.17
9	4.17
10	4.17
11	4.17
12	4.17
13	4.17
14	4.17
15	4.18
16	4.2
17	4.2
18	4.17
19	4.18
20	4.17
21	4.17
22	4.17
23	4.17
24	8.36
25	3.21
26	3.21
27	GND
28	4.19
U701	
1	GND
2	1.37
3	1.49
4	GND
5	1.32
6	1.65
7	3.34
8	NC
9	NC
10	3.32
11	3.29
12	NC
13	NC
14	3.32
15	3.3
16	3.25
17	3.18
18	3.56
19	NC
20	3.21
21	3.21
22	3.34
23	GND

Pin No.	Voltage
24	NC
25	NC
26	3.34
27	3.34
28	3.34
U703	
1	3.3
2	1.65
3	1.65
4	1.65
5	AGND
6	1.65
7	1.65
8	0.01
9	3.02
10	1.65
11	1.65
12	1.65
13	1.65
14	1.65
15	1.65
16	1.65
17	3.3
18	3.19
19	0.12
20	3.19
21	3.3
22	3.3
23	0.12
24	3.27
25	1.65
26	1.81
27	DGND
28	1.65
29	3.19
30	3.16
31	NC
32	DGND
33	3.29
34	1.65
35	1.68
36	1.61
37	1.81
38	1.42
39	1.62
40	1.3
41	1.65
42	DGND
43	DGND
44	1.65
45	1.65
46	0.32
47	3.28
48	1.23
49	1.3
50	DGND
51	DGND
52	NC
53	3.28
54	AGND
55	1.65
56	1.65

Pin No.	Voltage
57	1.65
58	3.28
59	DGND
60	0.73
61	1.65
62	1.65
63	1.65
64	1.95
U704	
1	3.56
2	3.52
3	3.54
4	3.53
5	1.64
6	1.64
7	7.74
8	7.74
9	7.74
10	7.16
11	3.31
12	NC
13	NC
14	NC
15	NC
16	NC
17	NC
18	GND
19	3.56
20	3.56
21	3.56
22	3.56
23	1.65
24	1.65
25	7.66
26	1.65
27	GND
28	GND
29	3.01
30	3.25
31	0
32	NC
33	3.25-6.01
34	3.25-6.01
35	GND
36	NC

PRINTED CIRCUIT BOARD DIAGRAMS

1-1. MAIN P.C. BOARD DIAGRAM (TOP VIEW)

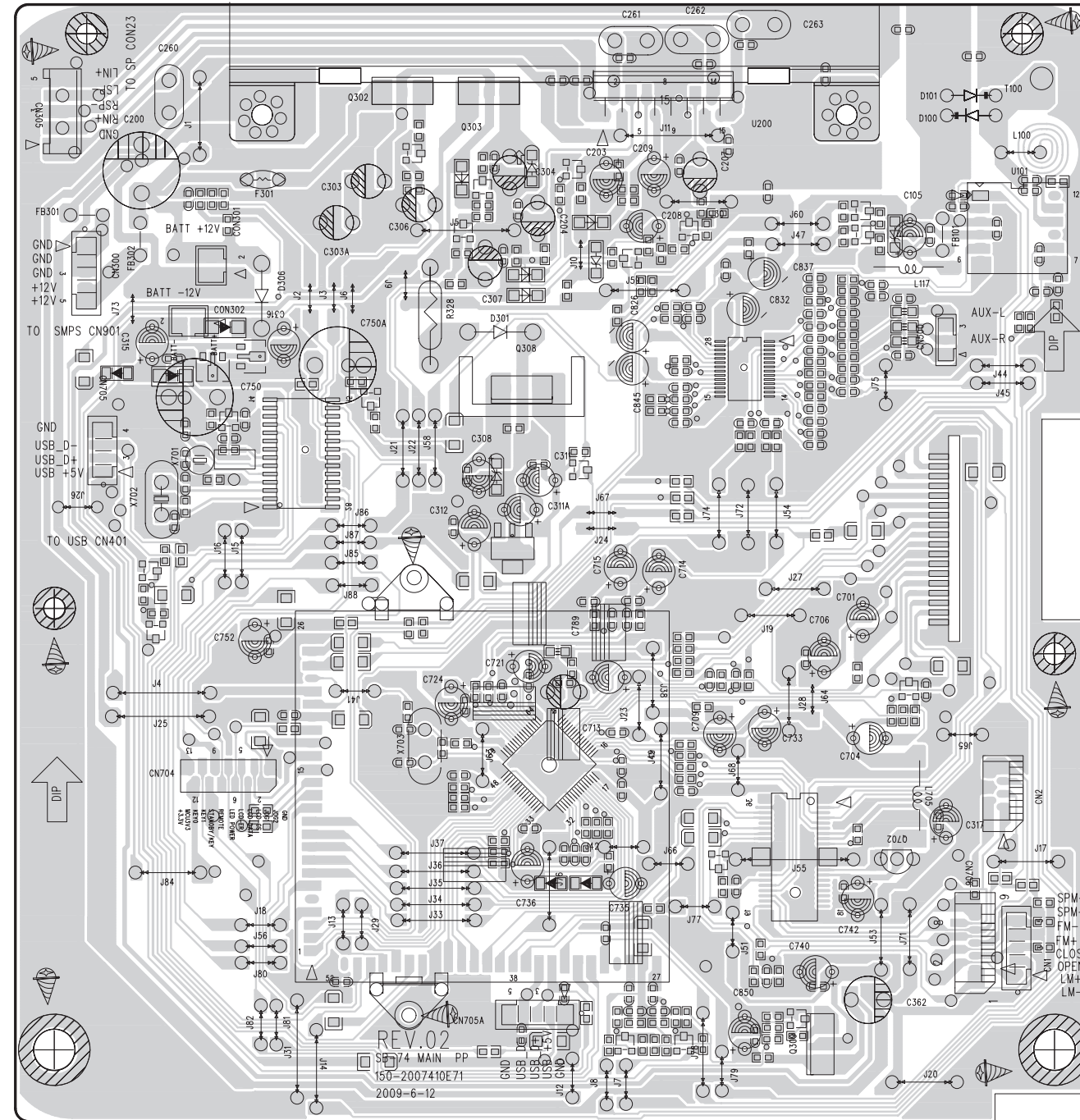

1-2. MAIN P.C. BOARD DIAGRAM (BOTTOM VIEW)

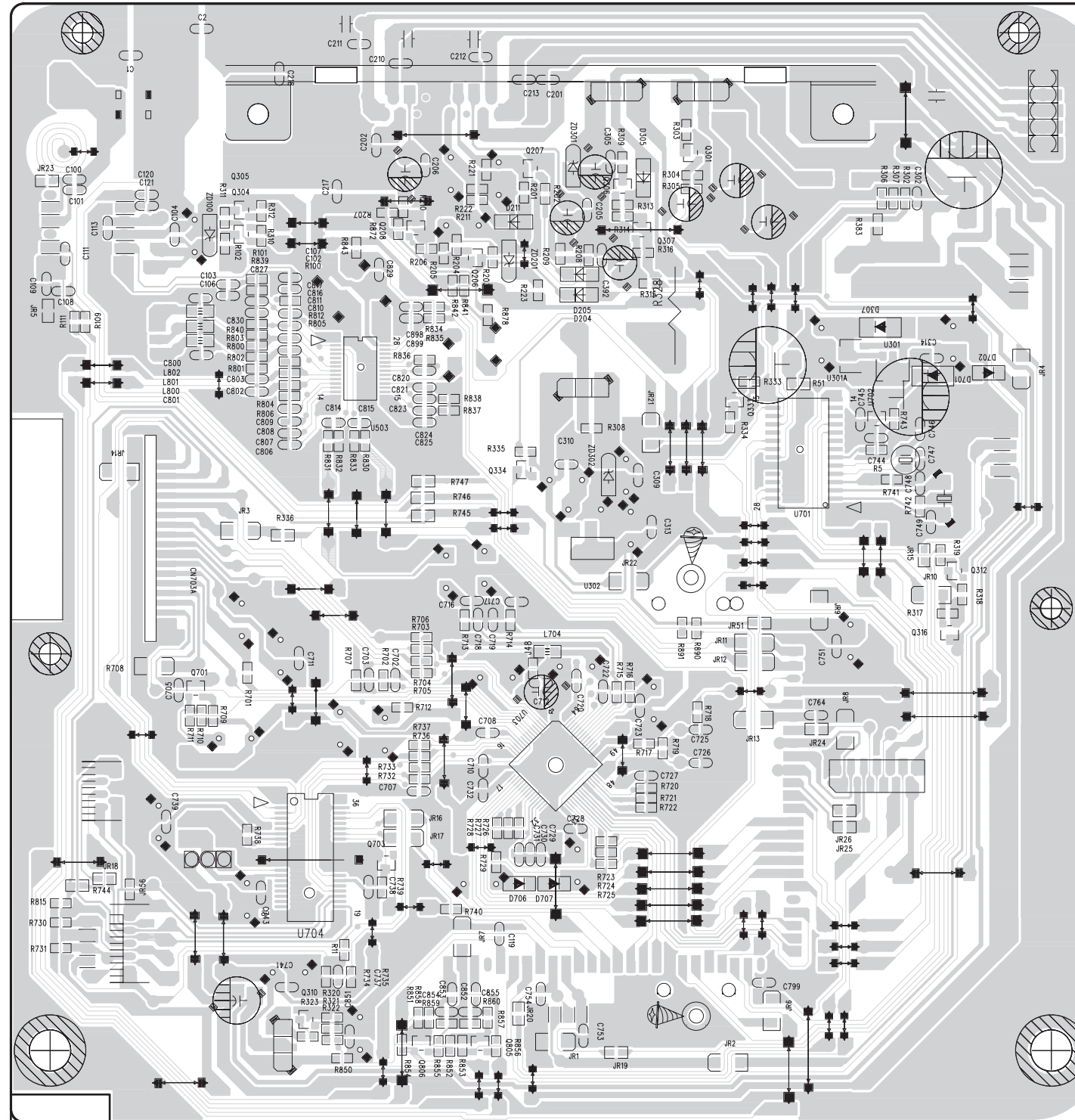

2. SMPS P.C. BOARD DIAGRAM

NOTE: Warning
 Parts that are shaded are critical With respect to risk of fire or electrical shock.

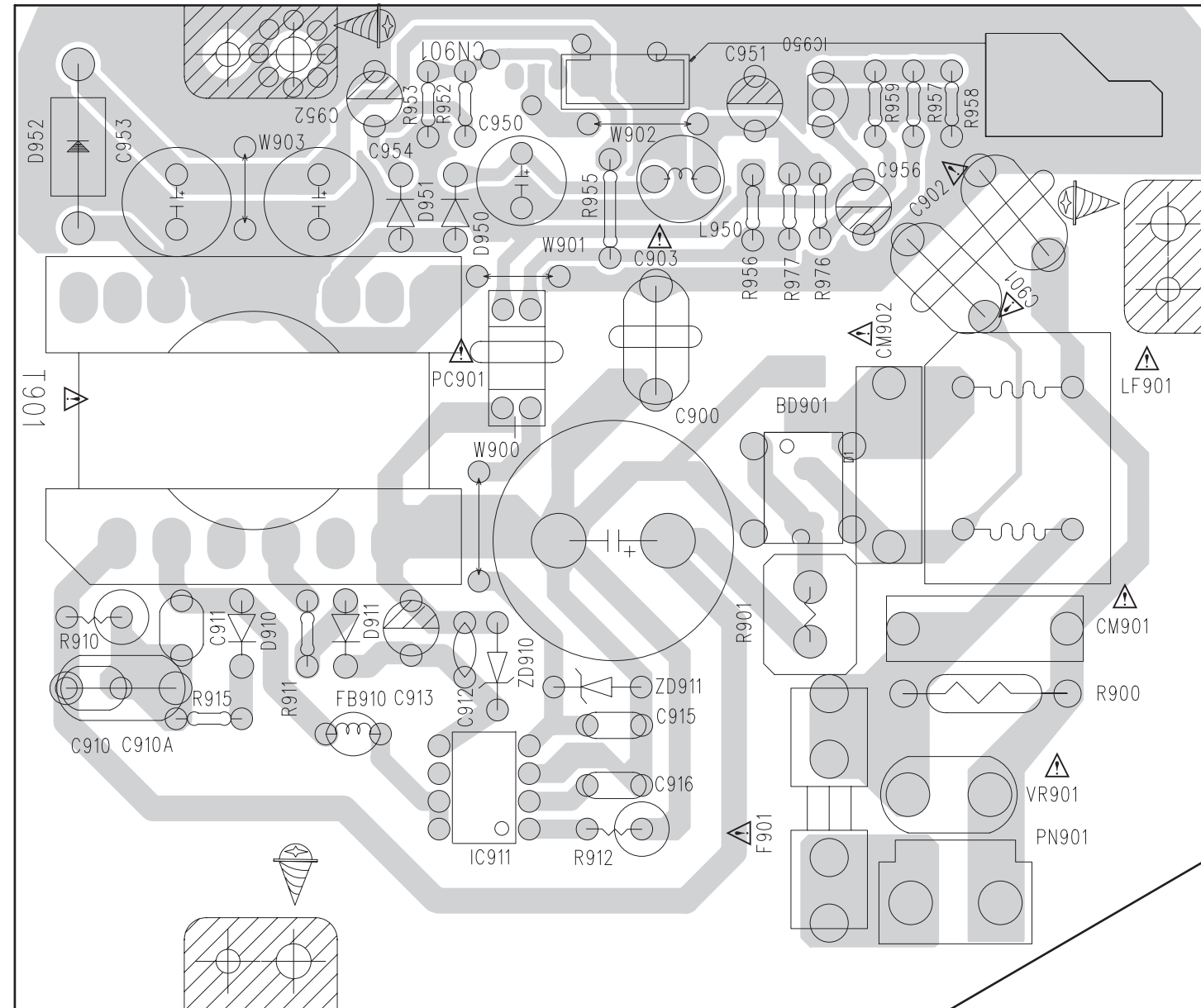

3-1. MCU9800 P.C. BOARD DIAGRAM (TOP VIEW)

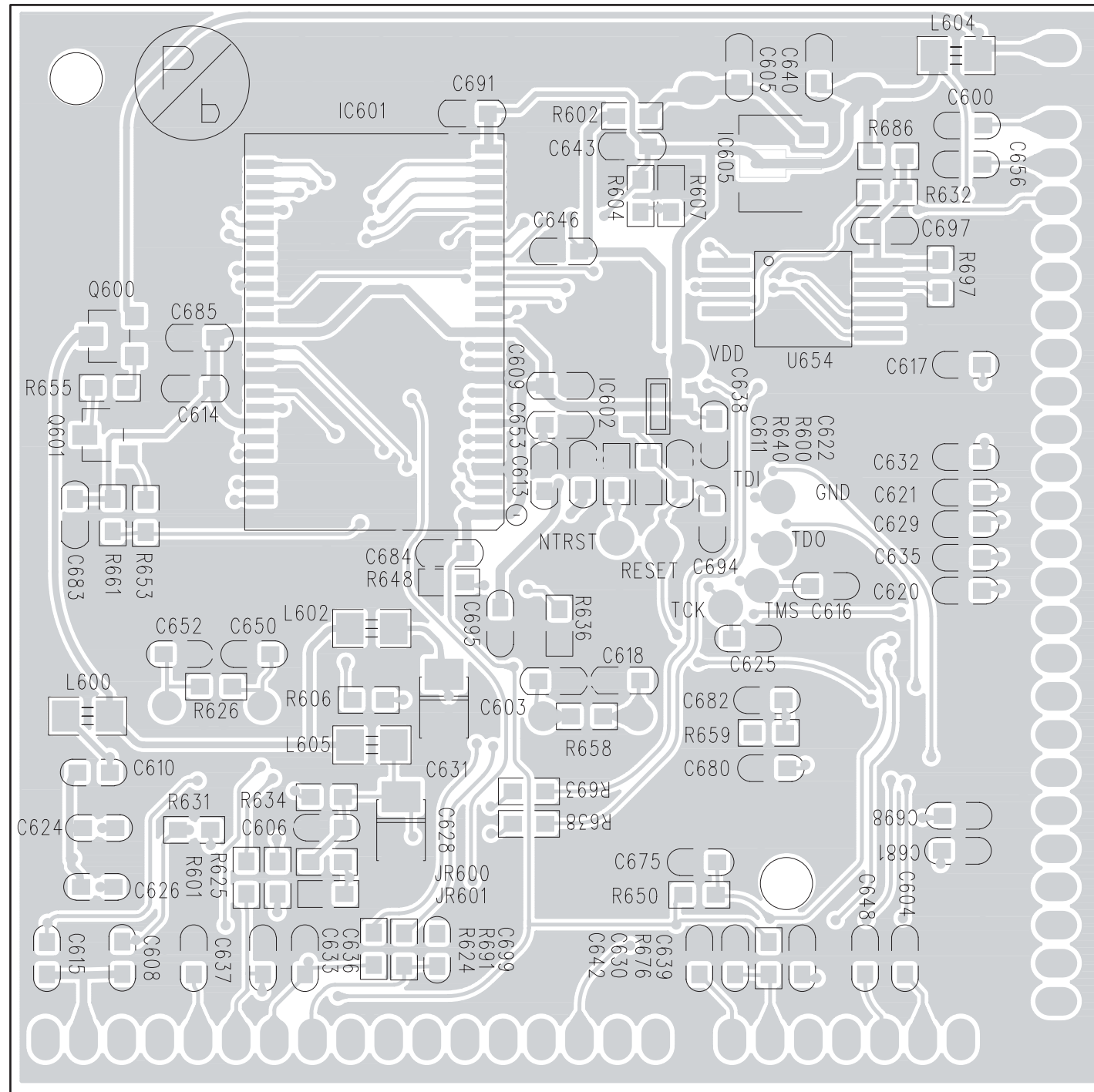

3-2. MCU9800 P.C. BOARD DIAGRAM (BOTTOM VIEW)

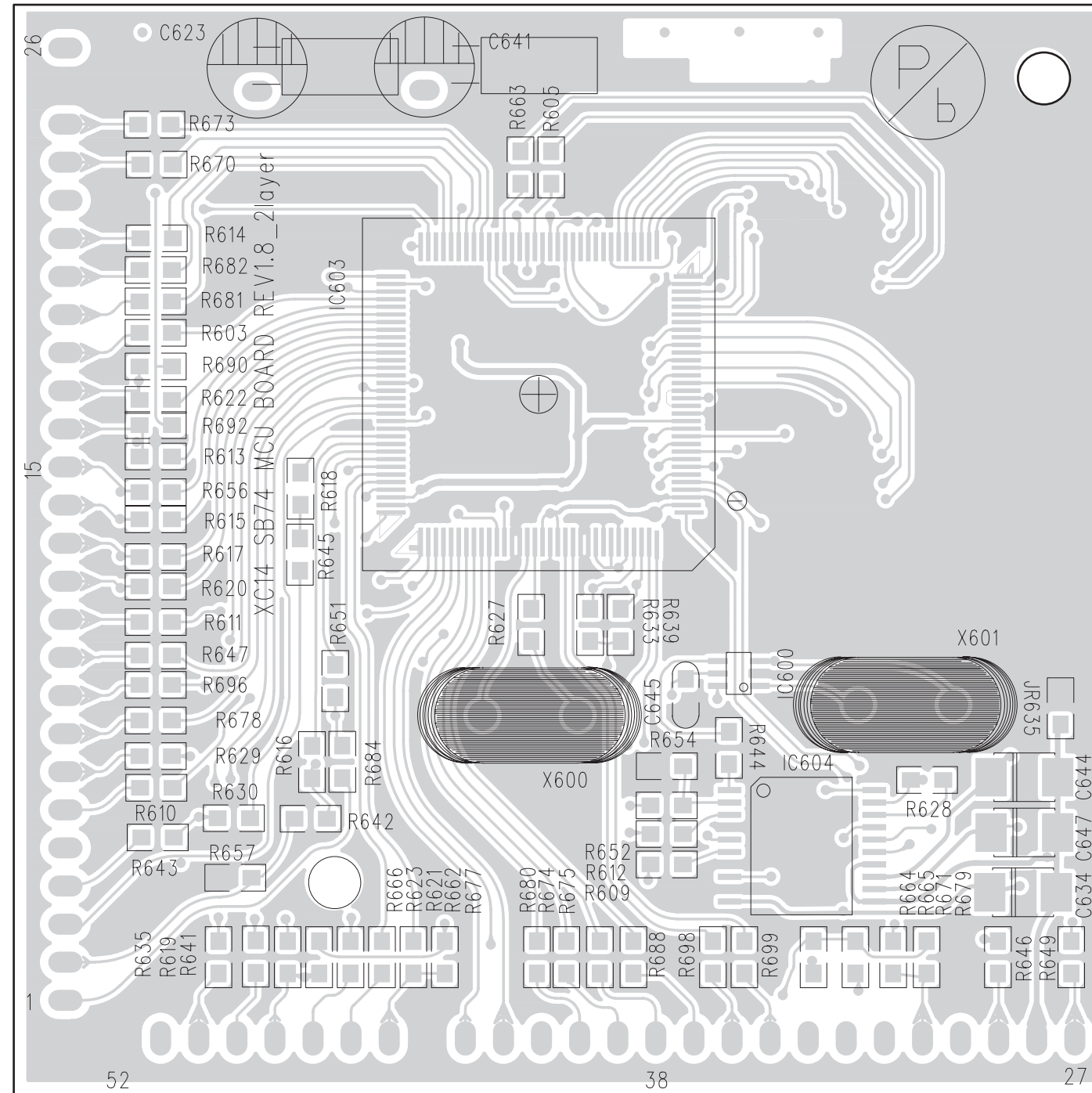

4. FRONT P.C. BOARD DIAGRAM

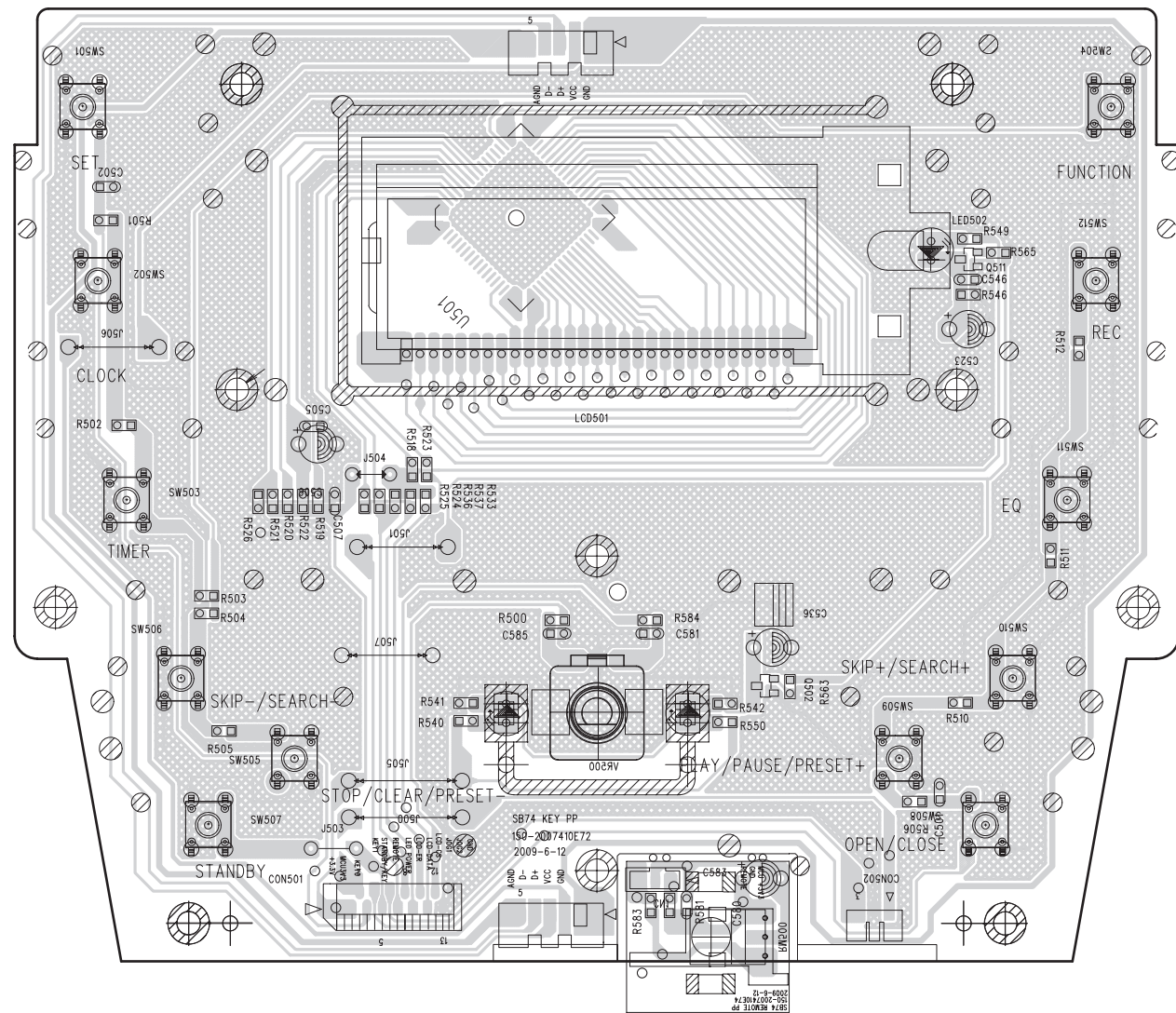
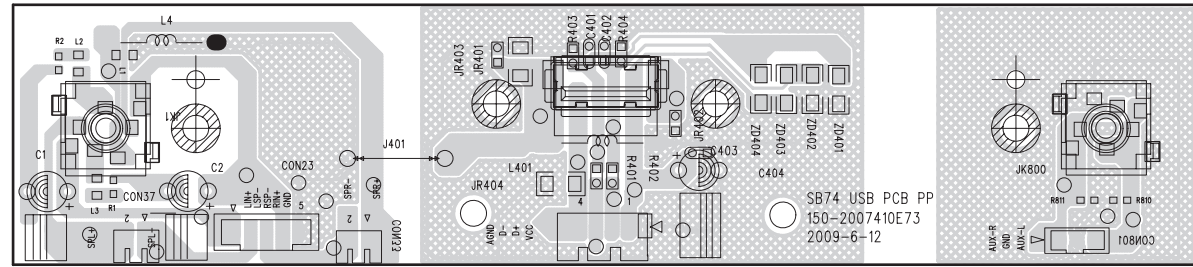

5. CD JACK P.C. BOARD DIAGRAM

