

7. Circuit diagram

7-1 [220V/50, 60Hz, 230~240V/50Hz] SR-28/29, SR-32/33

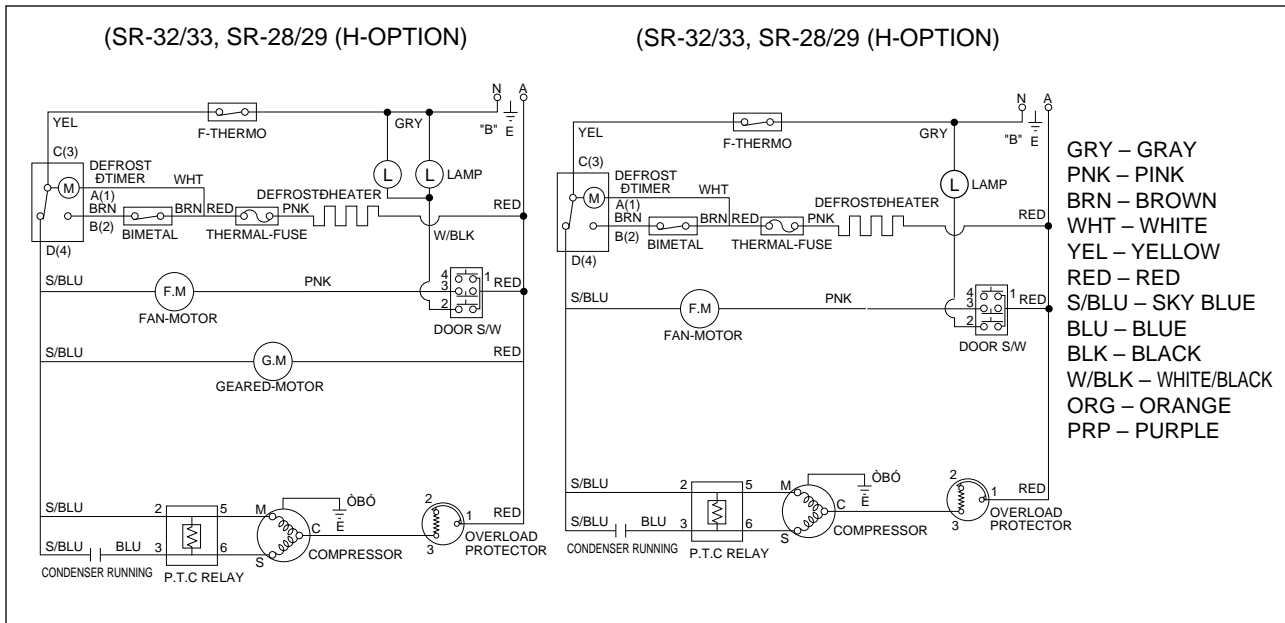

7-2 [110V/ 60Hz, 115V/60Hz, 127V/60Hz] SR-28/29, SR-32/33

