

TOSHIBA

Leading Innovation >>>

SERVICE MANUAL

LCD Color Television

32P1300D(G)

CONTENTS

1. IMPORTANT NOTICE
2. GREEN PRODUCT PROCUREMENT
3. LEAD-FREE SOLDER
4. SAFETY INSTRUCTION
5. SERVICE MODE
6. INTERCONNECT
7. EXPLODED VIEW
8. SET ID and PANEL ID

IMPORTANT NOTICE

WARNING:

You are requested that you shall not modify or alter the information or data provided herein without prior written consent by Toshiba. Toshiba shall not be liable to anybody for any damages, losses, expenses or costs, if any, incurred in connection with or as a result of such modification or alteration.

THE INFORMATION OR DATA HEREIN SHALL BE PROVIDED "AS IS" WITHOUT ANY WARRANTY OF ANY KIND, EITHER EXPRESS OR IMPLIED WARRANTY OF MERCHANTABILITY AND FITNESS FOR A PARTICULAR PURPOSE.

Toshiba shall not be liable for any damages, losses, expenses or costs, if any, incurred in connection with or as a result of use of any information or data provided herein.

GREEN PRODUCT PROCUREMENT

The EC is actively promoting the WEEE & RoHS Directives that define standards for recycling and reuse of Waste Electrical and Electronic Equipment and for the Restriction of the use of certain Hazardous Substances. From July 1, 2006, the RoHS Directive will prohibit any marketing of new products containing the restricted substances.

Increasing attention is given to issues related to the global environmental. Toshiba Corporation recognizes environmental protection as a key management tasks, and is doing its utmost to enhance and improve the quality and scope of its environmental activities. In line with this, Toshiba proactively promotes Green Procurement, and seeks to purchase and use products, parts and materials that have low environmental impacts.

Green procurement of parts is not only confined to manufacture. The same green parts used in manufacture must also be used as replacement parts.

LEAD-FREE SOLDER

This product is manufactured using lead-free solder as a part of a movement within the consumer products industry at large to be environmentally responsible. Lead-free solder must be used in the servicing and repair of this product.

**WARNING: This product is manufactured using lead free solder.
DO NOT USE LEAD BASED SOLDER TO REPAIR THIS PRODUCT!**

The melting temperature of lead-free solder is higher than that of leaded solder by 30°C to 40°C (54°F to 72°F). Use of a soldering iron designed for lead-based solders to repair product made with lead-free solder may result in damage to the component and or PCB being soldered. Great care should be made to ensure high-quality soldering when servicing this product especially when soldering large components, through-hole pins, and on PCBs as the level of heat required to melt lead-free solder is high.

SAFETY INSTRUCTION

WARNING: BEFORE SERVICING THIS CHASSIS, READ THE "SAFETY PRECAUTION" AND "PRODUCT SAFETY NOTICE" INSTRUCTIONS BELOW.

Safety Precaution

WARNING: SERVICING SHOULD NOT BE ATTEMPTED BY ANYONE UNFAMILIAR WITH THE NECESSARY PRECAUTIONS ON THIS RECEIVER. THE FOLLOWING ARE THE NECESSARY PRECAUTIONS TO BE OBSERVED BEFORE SERVICING THIS CHASSIS.

1. An isolation transformer should be connected in the power line between the receiver and the AC line before any service is performed on the receiver.
2. Always disconnect the power plug before any disassembling of the product. It may result in electrical shock.
3. When replacing a chassis in the cabinet, always be certain that all the protective devices are put back in place, such as nonmetallic control knobs, insulating covers, shields, isolation resistor-capacitor network, etc.
4. Always keep tools, components of the product, etc away from the children, These items may cause injury to children.
5. Depending on the model, use an isolation transformer or wear suitable gloves when servicing with the power on, and disconnect the power plug to avoid electrical shock when replacing parts. In some cases, alternating current is also impressed in the chassis, so electrical shock is possible if the chassis is contacted with the power on.
6. Always use the replacement parts specified for the particular model when making repairs. The parts used in products require special safety characteristics such as inflammability, voltage resistance, etc. therefore, use only replacement parts that have these same characteristics. Use only the specified parts when the  mark is indicated in the circuit diagram or parts list.
7. Parts mounting and routing dressing of wirings should be the same as that used originally. For safety purposes, insulating materials such as isolation tube or tape are sometimes used and printed circuit boards are sometimes mounted floating. Also make sure that wirings is routed and clamped to avoid parts that generate heat and which use high voltage. Always follow the manufactured wiring routes / dressings.

8. Always ensure that all internal wirings are in accordance before re-assembling the external casing after a repairing completed. Do not allow internal wiring to be pinched by cabinets, panels, etc. Any error in reassembly or wiring can result in electrical leakage, flame, etc., and may be hazardous.
9. NEVER remodel the product in any way. Remodeling can result in improper operation, malfunction, or electrical leakage and flame, which may be hazardous.
10. Touch current check. (After completing the work, measure touch current to prevent an electric shock.)
 - Plug the AC cord directly into the AC outlet. Do NOT use an isolation transformer for this check.
 - Connect a measuring network for touch currents between each exposed metallic part on the set and a good earth ground such as a water pipe.

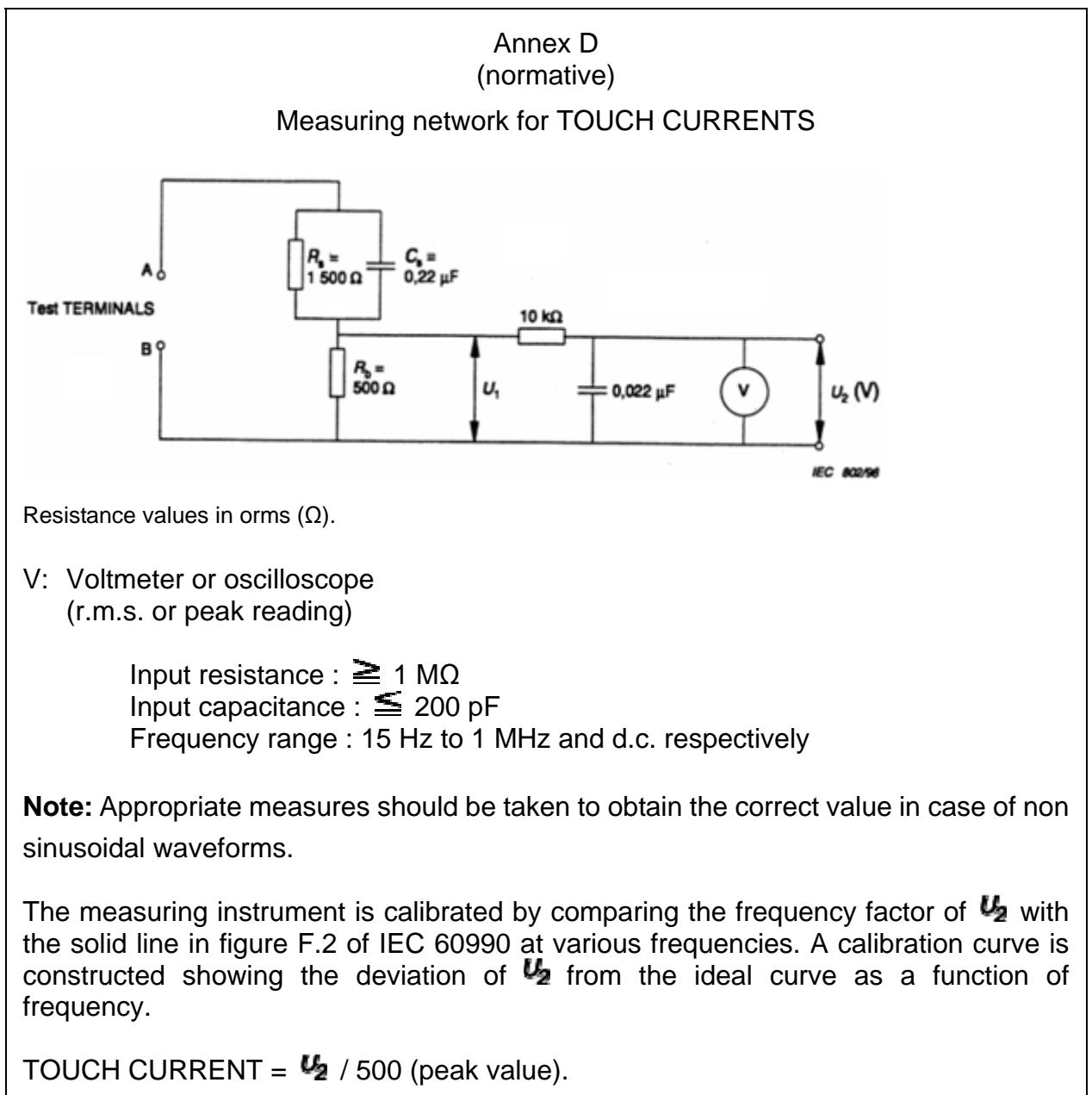

- The potential at any point (TOUCH CURRENT) expressed as voltage U_1 and U_2 does not exceed the following value:

The part or contact of a TERMINAL is not HAZARDOUS LIVE if:

- a) The open-circuit voltage should not exceed 35 V (peak) a.c. or 60 V d.c. or, if a) is not met.
- b) The measurement of the TOUCH CURRENT shall be carried out in accordance with IEC 60990, with the measuring network described in **Annex D** of this standard.

The TOUCH CURRENT expressed as voltages U_1 and U_2 , does not exceed the following values:

- for a.c. : $U_1 = 35$ V (peak) and $U_2 = 0.35$ V (peak);
- for d.c. : $U_1 = 1.0$ V

Note: The limit values of $U_2 = 0.35$ V (peak) for a.c. and $U_1 = 1.0$ V for d.c. correspond to the values 0.7 mA (peak) a.c. and 2.0 mA d.c.





Product Safety Notice

Many electrical and mechanical parts in this chassis have special safety-related characteristics. These characteristics are often passed unnoticed by a visual inspection and the protection afforded by them cannot necessarily be obtained by using replacement components rated for higher voltage, wattage, etc. Replacement parts which have these special safety characteristics are identified in this manual and its supplements; electrical components having such features are identified by the international hazard symbols on the schematic diagram and the parts list.

Before replacing any of these components, read the parts list in this manual carefully. The use of substitute replacement parts which do not have the same safety characteristics as specified in the parts list may create electrical shock, fire, or other hazards.

SERVICE MODE

ENTERING SERVICE MODE

- 1) Press  button once on Remote Control.
- 2) Press  button again and keep pressing.
- 3) While pressing the  button, press  /  button on TV set.

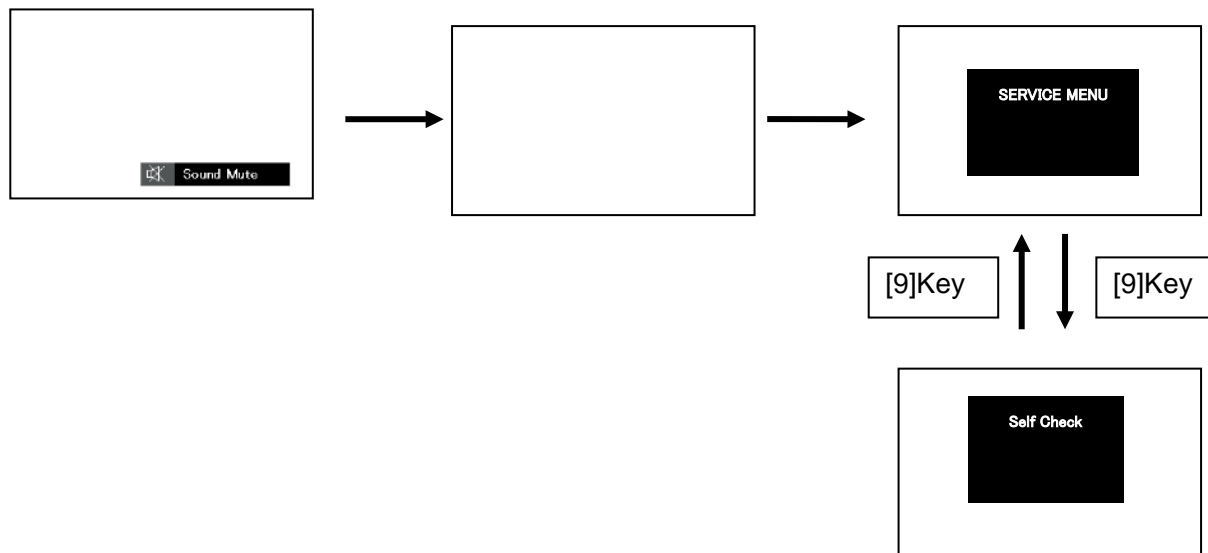

ADJUSTING ITEMS IN THE SERVICE MODE

Special setting

	Item	Value	Purpose
	Vertical Line	Normal, Special	if the picture have "Vertical Line problem", user can use the "special setting" to improve this problem
A	V Lock	Normal, Special	if the picture have "up-down jitter problem", user can use the "special setting" to improve this problem
B	White Tail	Normal, 1, 2, 3, 4	if the picture have "White Tail problem", user can adjust the setting to improve this problem
	Color Flicker	Normal, Special	When the color of the screen is flashing user can use the "special setting" to improve this problem
	White Peak	Normal, Special	if the picture have "bright dark flashing problem", user can use the "special setting" to improve this problem
C	H Jitter	Normal, _00, _01, _02, _03, _04, _05	if the picture have "left- right jitter problem", user can use the "special setting" to improve this problem
A	Vsync Threshold	Normal, 1,2	if the vsync of the signal is not locking ,user can use the "special setting" to improve this problem Normal is current condition. 1 is current special + add one register (for Mumbai Ch2). 2 is 3 combination (Change IFD Gain+V th+ V PLL)(for Delhi Ch2).
D	IF AGC Speed	196,206,216,219,222,248,250,251,Default,89,105,121,137,158,172,185	the default setting is the 196, user can use this setting to change the if AGC speed When user changes setup, setting value is held to each CH.
	LogDebug	Enable/Disable	Default: Disable for TEST purpose
E	Signal det.Hsync	Normal/Special	Normal is current condition (Vsync and Hsync) Special is new condition (Hsync only)
	Factory Reset		Execute Factory Reset (Shipment condition)
F	CH WIDTH VIDEO SYS	Normal/Special	Normal is current condition Special is new condition (VIDEO SYSTEM:PAL-G) When user changes setup, setting value is held to each CH. PAL-G is Tuner si2156 control setting.
D	Agc loop 1 dn sample	Normal/Special	Normal is current condition (" 3 " Setting) Special is new condition (" 0 " Setting) When user changes setup, setting value is held to each CH.

A : These item are similar phenomenon. So please try both items.

B : The picture have white horizontal flare or some portion lost horizontal synchronize (disarray).

In this case please try to change "White tail" 1, 2, 3, or 4. Then please choose the best one.

C : If the picture have horizontal jitter please try to change this "H Jitter" 01, 02, 03, 04, and 05.

Then please select the best one.

D : If the picture have horizontal bar noise or unlock synchronize please try to reduce this value.

E : If the picture have full screen Picture jumping up / down please try a change to "special".

F : If the picture have horizontal stripes please try a change to "special".

SELF CHECK

- "Self Check" screen is shown by pressing "9" button on Remote Control during display of the Service mode adjustment menu.
- "Self Check" screen should not be erased by timeout.

Self Check OSD		
1	TV Model	32P1300D_A_LGD
2	Model ID	0x03
3	Boot Version	00000
4	APP SW Version	00000
5	PQ Data Version	00
6	AQ Data Version	00
7	Language H	Enable
8	CEC Playback Control	Disable
9	HDCP Key	Pass [EEPROM]
10	POT	00000
11	MAIN FORMAT	1080i 60
12	MAIN TUNER FREQ	00000000
13		

Item	Explanation /Data Format
TV Model	"Model name"+"_"+"Suffix(A or B)"+"_"+"Panel vender" e.g. 32P1300D_A_LGD Model name : 29P1300D, 32P1300D Suffix: A Panel vender : LGD:LGD , CMI:CMI
Model ID	Model ID indicating panel size and vender Display 1 byte data.(Hex)
Boot Version	Version information of boot code.
APP SW Version	Version information of Application SW.
PQ Data Version	Version information of Picture Quality Data.
AQ Data Version	Version information of Audio Quality Data.
Language H	Manu Language option for VQ model Enable : Enable to select Menu Language for VQ model. Disable : Disable to select Menu Language for VQ model.
CEC Playback Control	Pass through of playback control keys option for HDMI-CEC Enable : Playback control keys are handled as pass through. Disable : Playback control keys are not handled as pass through.
HDCP key	HDCP key in the memory Pass(FLASH) : HDCP key is detected in Flash-ROM Pass(EEPROM) : HDCP Key is detected in External EEPROM Fail : HDCP key is not detected
POT	Power On Time Total time the TV has been powered on. (Unit: Hours) (Decimal) * Writing the POT data to Flash ROM should be done only once in an hour. (The time less than one hour can be ignored.) * POT should be cleared to 0 by the ship-out factory command (40EE00FF).
MAIN FORMAT	Video format information (e.g. 480i60, 1080i50, 1024 x 768 @60Hz)
MAIN TUNER FREQ.	Displays tuned frequency (Unit: kHz) (Decimal)

MODEL ID TABLE

Model ID	Inch & Vendor	Model Name in Self Check OSD
0x00	Not used	
0x01	29P1300_CMI 29P1300D_CMI	29P1300_A_CMI 29P1300D_A_CMI
0x02	Reserved	
0x03	32P1300_LGD	32P1300_A_LGD
0x04	32P1300_LGD 32P1300D_LGD	32P1300_A_LGD 32P1300D_A_LGD
0x05	32P1300_AUO(TBD)	32P1300_A_AUO
0x06	32P1300_CMI(TBD)	32P1300_A_CMI
0x07	Reserved	
0x08	24P1300_CMI	24P1300_A_CMI
0x09	Reserved	
0x0A	Reserved	
0x0B	Reserved	

Note

P1300D (East Euro) is the following two Model.

- 29P1300D_CMI
- 32P1300D_LGD

SETTING HOTEL MODE

Hotel mode allows for customizing specified TV operations that are suitable for hotel use.

ENTERING HOTEL MODE MENU

Hotel Mode Menu should be shown by the following operation.

- 1) Press **X** button once on the Remote Control.
- 2) Press **X** button again and keep pressing.
- 3) While pressing the **X** button, press “+” button on TV set.



(Hotel Mode Settings Menu)

DISPLAY OF HOTEL MODE MENU

- The Hotel Mode Menu should always be shown in English regardless of the Menu Language setting.
(Translation of the words in the Hotel Mode Menu will not be provided.)

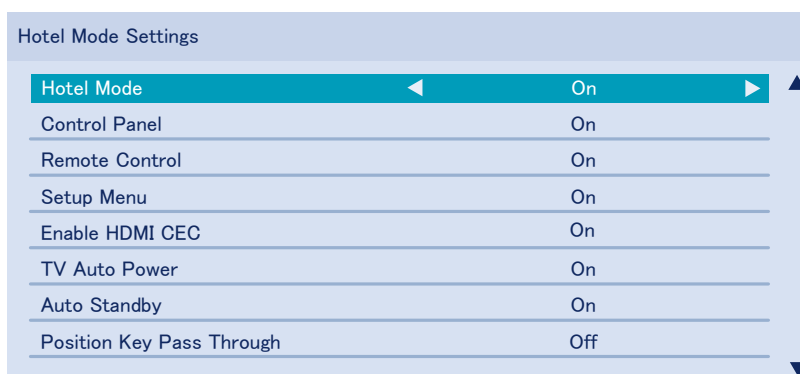

(Example of Menu Image)

OPERATING HOTEL MODE MENU

- To enable Hotel Mode, use the ◀ or ▶ arrow keys while “Hotel Mode” item is highlighted to select “On”. Once Hotel Mode is on, the Hotel Mode settings will be enabled for adjusting.
- Use ▲ and ▼ buttons to access the hotel mode settings.
Use ◀ and ▶ buttons to change the settings.
See the table below for explanation of each setting.
- Press Exit when finished adjusting the settings.

Item	Options	Description	Factory settings
Hotel Mode	Off	Disable Hotel Mode. All the settings of Hotel Mode are disabled.	Off
	On	Enable Hotel Mode	
Control Panel	On	Allow use of all Control panel buttons	On
	Off	Prohibit use of all control panel buttons. But, Power Off -> On by control panel POWER button is not prohibited. (Power On -> Off is prohibited.) * Entering Service mode/Hotel mode Menu/Hotel Clone is not prohibited. * Control panel buttons are available during Service mode.	
Remote Control	On	Remote Enabled	On
	Off	Remote Disabled * The following remote codes are not disabled. - SOUND MUTE (40BF10) - Super User mode (40BFFE) - S mode (40EEC3) * Remote Enabled during Service mode/Hotel mode Menu/Hotel Clone.	
Setup Menu	On	Allow access to SETUP menu	On
	Off	Prohibit access to the setup menu.	
	Off (Except Language)	Prohibit access to all items in the setup menu except for the Language setting.	
Enable HDMI CEC	On	Enable to use CEC feature	Off
	Off	"TV Auto Power" and "Auto Standby" and "Position Key Pass Through" are grayed out. CEC feature will not be available regardless the settings.	
TV Auto Power	On	Control power On/Off from external device	On
	Off	Prohibit control of power On/Off from external device	
Auto Standby	On	Execute standby to external device	On
	Off	Prohibit control of standby to external device	
Position Key Pass Through	On	Pass through position keys to external device.	Off
	Off	Prohibit "pass through" to external device.	
Max Volume	0-100	Set maximum volume level. It limits the volume level which can be set by Volume button. If you set it to 70, Volume bar can not go to 71 or higher.	100

Change POS/VIDEO	Off	TV Tunes to the last channel or input viewed when powered on	Off
	On	TV tunes to preset "POS/VIDEO" (channel or input) when TV is powered on.	
	On (AC)	TV tunes to preset "POS/VIDEO" (channel or input) only when AC power is applied. When TV is powered on by power button, tune to the last channel or input.	
POS/VIDEO (only available when "Change POS/VIDEO" is On)	0-99	0-99 (TV Channel Position)	0
	VIDEO	Number of input is depends on model.	
	HDMI	Number of input is depends on model.	
Change Volume	Off	TV volume level does not change when TV powers on	Off
	On	TV volume level is forced to "Volume" level when TV is powered on	
Volume (only available when "Change Volume" is On)	0-100	Volume level when TV is powered on (Level bar is displayed)	30
Change Picture Mode	Off	Picture setting mode does not change when TV is powered on	Off
	On	Picture setting mode is forced to "Picture Mode" mode when TV is powered on	
Picture Mode (only available when "Change Picture Mode" is On)	Dynamic	Dynamic	Standard
	Standard	Standard	
	Mild	Mild	
	Movie	Movie	
TV Power	Disabled	TV returns to previous Standby/On State when AC power is applied	Disabled
	Force On	Power TV on when AC power is applied	
	Force Standby	Put TV in Standby when AC power is applied	
Position Change on HDMI Input	Enabled	RF tuning via P▲, P▼, BACK, and number buttons is allowed. (Normal operation)	Enabled
	Disabled	When viewing HDMI input, RF tuning via P▲, P▼, BACK, and number buttons is disabled.	

RESETTING HOTEL MODE SETTINGS

- Hotel Mode settings should be reset by special remote code for Factory Ship out.
(Default values will be restored)
- Hotel Mode settings should NOT be reset by “Reset TV” on the SETUP menu.
(To prevent users from cancelling Hotel Menu settings that has been specially set by the hotel)

CLONING HOTEL MODE SETTINGS

- Hotel Mode settings should be copied to other TV by HOTEL CLONE function.





SETTING HOTEL MODE VIA CLONE MENU

The following settings can be copied between sets using the clone menu:

- Hotel Mode menu settings
- ATV Channel Setup
 - Programme (position)
 - System
 - Colour System
 - Programme Skip
 - Signal Class
 - Channel
 - Manual Fine Tuning
 - Signal Booster
 - Label

COPYING HOTEL MODE SETTINGS FROM TV TO USB DRIVE

- 1) Configure the hotel mode settings via the Hotel Mode Menu (see previous sections for instructions).
- 2) Setup channel list via Setup Menu.
- 3) Access the Hotel Clone menu using steps a-c.

- a) Press  button once on the Remote Control.
- b) Press  button again and keep pressing.
- c) While pressing the  button, press  button on TV set.

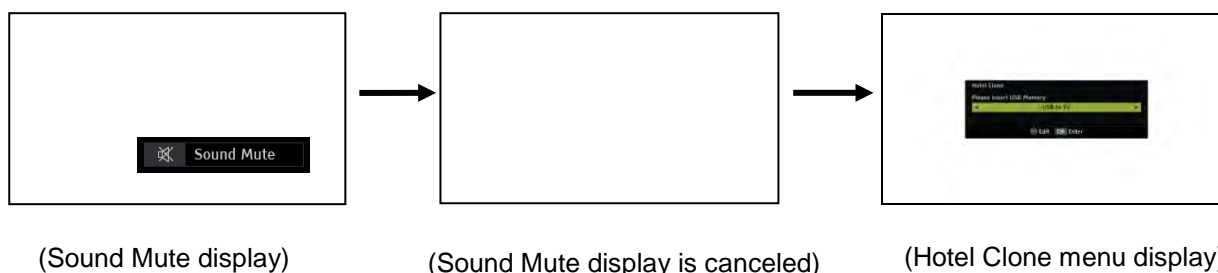





- 4) Select “TV to USB” using the ◀ or ▶ arrow keys.



- 5) Insert USB Drive and press OK to copy settings to the USB drive.
- 6) Wait for window that indicates the copying process is complete before removing the USB drive.

COPYING HOTEL MODE SETTINGS FROM USB DRIVE TO TV

1) Access the Hotel Clone menu using steps a-c.

- a) Press  button once on the Remote Control.
- b) Press  button again and keep pressing.
- c) While pressing the  button, press "" button on TV set.

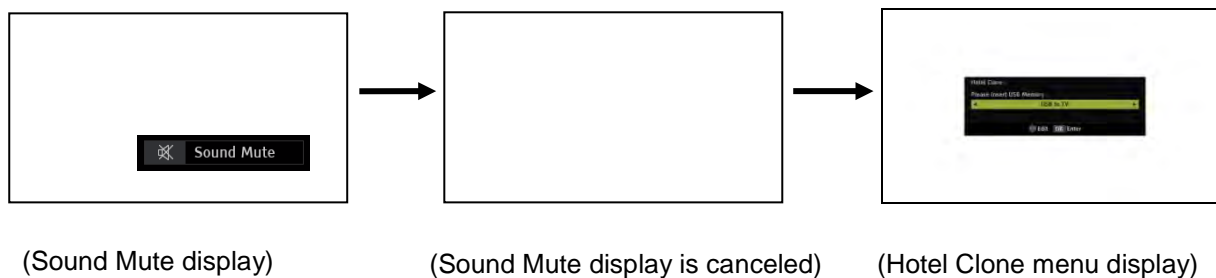

2) Select "USB to TV" using the ◀ or ▶ arrow keys.

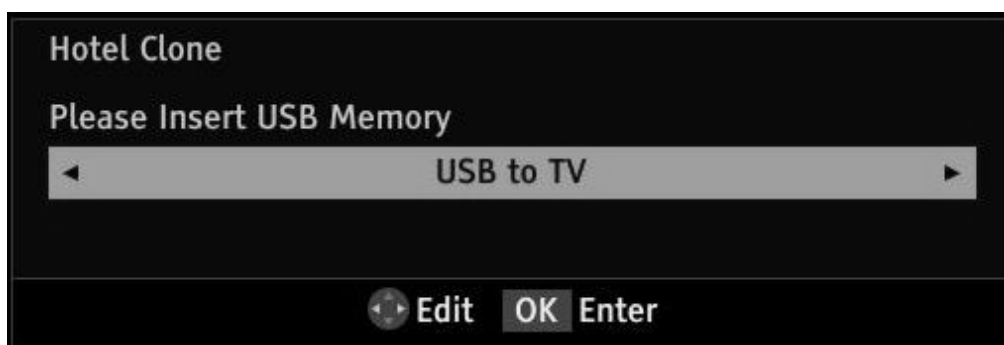

- 3) Insert USB Drive that settings have previously been saved to and press OK to copy settings to the TV.
- 4) Wait for settings to be copied.

When the copying has finished successfully, the message "The TV will reboot when this window is closed." will be displayed. If the copying is not successful, an error message will be displayed.
- 5) Exit the menu and the TV will reboot.
- 6) Remove the USB drive.

Note:

If TV status is "out of Box" condition, when turn on the TV first, "Quick Setup" screen will be displayed. Before copying data to TV from USB by using Hotel Clone function, it is necessary to execute Auto Tuning for the purpose of disappearing the "Quick Setup" screen.

TV SOFTWARE UPGRADE

Steps to Upgrade TV-Microcomputer Software via USB Flash Memory.

- 1) Unplug the TV.
- 2) Prepare a USB device which contains the software update.
- 3) Insert the USB device into the USB terminal of the TV.
- 4) Plug in TV and watch LED on the front of the set.
- 5) You can see Orange LED on TV during updating.
Please never power off during updating.
- 6) You can see Green LED that lights without blinking on TV after the update has completed.
- 7) Unplug the TV.
- 8) Remove the USB device.
- 9) Plug in the TV.
- 10) If updating succeeded, TV will turn on normally. (Normal: No LED blinking).
- 11) If updating failed, the LED of TV will show another condition. (LED disappears or keeps orange).
In this case, please Re-Update the Software.

Note:

Remove HDMI apparatus at the time of the software update.

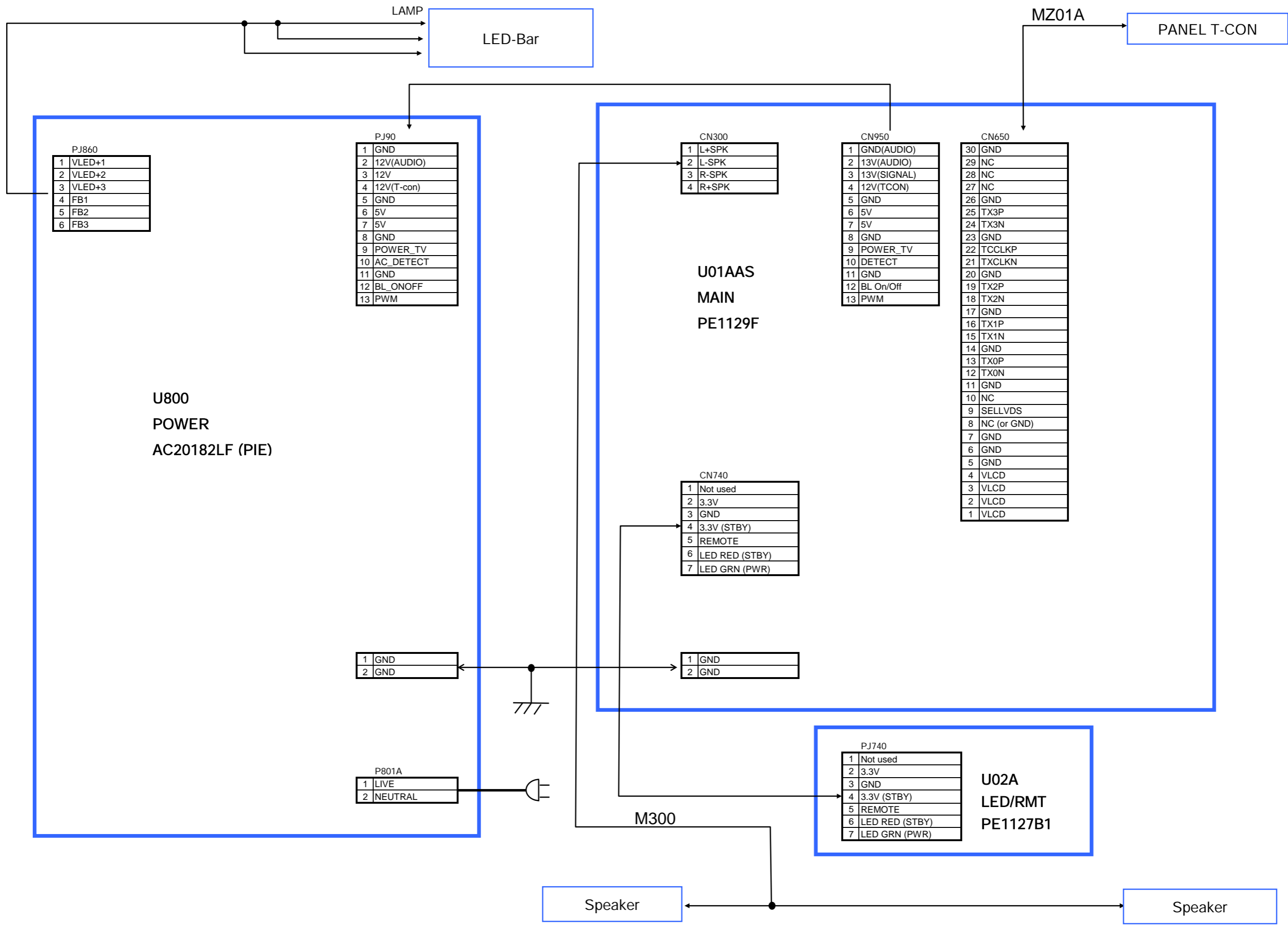

EXPLODED VIEW

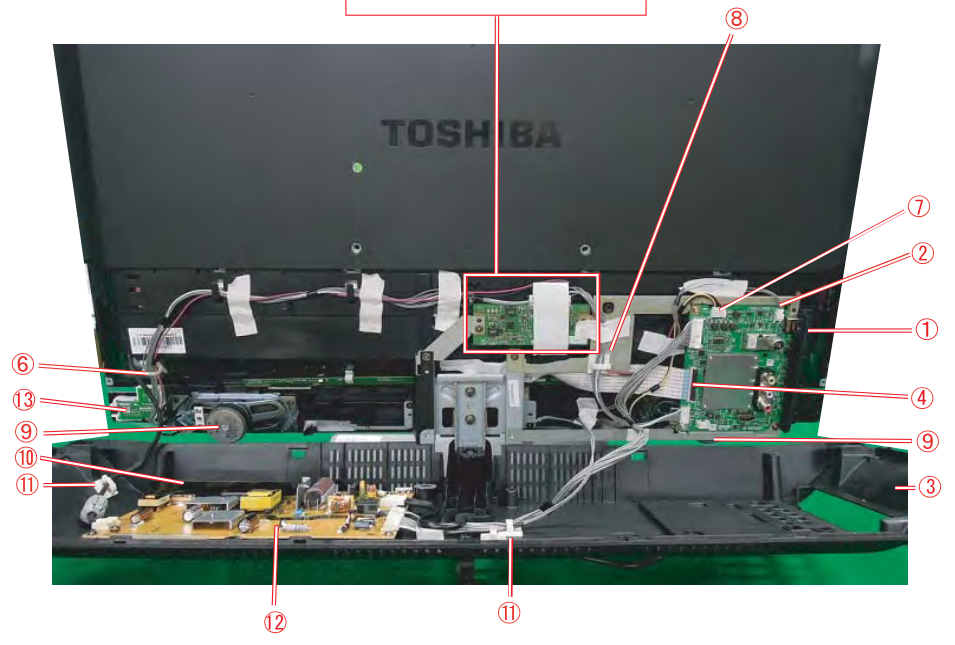

32P1300D

No.	Location	Toshiba Service Part	Description
1	A321S	75035262	KEY PLATE ASSY (FOR SERVICE USE)
2	⚠ U01AAS	75035263	PC BOARD ASSY, MAIN(FOR SERVICE USE), PE1129F, LG
3	⚠ A401S	75034381	COVER ASSY, UNIT (FOR SERVICE USE)
4	MZ01A	75035259	CABLE, FFC, 30P P1.0 L260 2-FOLD-SHIELD
5	MZ02A	75035260	CABLE, FFC, 50P P0.5 L140 2-FOLD-SHIELD
6	PP02	75018648	CLAMP, LWST-0512
7	M300	75031134	WIRE HARNESS, P24284-YRT205_05(S)E/YRT110_05(S)E L220/770,4P
8	PP03	75018648	CLAMP, LWST-0512
9	W661	75025502	SPEAKER, SPK1537AR, 40X120 8OHM 10W
10	⚠ E02	75034123	SHEET, INSULATOR, POWER
11	PP22	75018648	CLAMP, LWST-0512
12	⚠ U800	75034314	PC BOARD ASSY, POWER UNIT, LIPS, AC20182LF
13	⚠ U02A	75034308	PC BOARD ASSY, LED_RMT, B910PE1127B1
14	A401C	75026939	PIECE, BAND CLAMP, 40TL838
15	A421	75035257	STAND ASSY, LEG
16	A422	75035256	BASE ASSY, STAND, LEG
17	⚠ P801	75035247	CORD, POWER, E-EUROPE, 132325/2

SAFETY PRECAUTION
 The parts identified by ⚠ mark are critical for safety. Replace only with part number specified. The mounting position of replacement is to be identical with originals.
 The substitute replacement parts which do not have the same safety characteristics as specified in the parts list may create shock, fire or other hazards.

(1) can be opened and removed upwards.

Note:
 These photographs are samples.
 These photographs differ from the mass-production product.

SET ID and PANEL ID

Panel ID in Global Serial No.

Total digits Max 14	YWK YWK <u>3 digits</u>	SET ID *** <u>3 digits</u>	SERIAL ***** <u>6 digits</u> (A00001-Z99999)	Panel ID ** <u>2 digits</u>
------------------------	-------------------------------	----------------------------------	---	-----------------------------------

YWK

Y: Year	8	2008	WK: Week	01	WK01
	9	2009		02	WK02
	A	2010		03	WK03
	B	2011		04	WK04
	C	2012		⋮	⋮
	⋮	⋮		53	WK53

Panel vendor Information (Panel ID)

13th digit:

Marking	Panel Vendor	Marking	Panel Vendor	Marking	Panel Vendor
A	AUO	J	TJP MODULE	S	SHARP
B	BriView	K	SAMSUNG	T	CSOT
C	CMO	L	LPL/LGD	U	TJP/CMI
D	CHILIN	M	TCL (BMS)	V	TJP/SAM
E		N		W	TJP/AUO
F		P	CPT	X	TEVP/CMI
G	TJP/LGD	Q		Y	TEVP/SAM
H	IPS	R		Z	TEVP/AUO

14th digit:

1-9

When the panel version is updated within the same panel vendor, the last digit will be incremented by 1.

Model/Panel Information

Model	SET ID	Panel ID	Panel
29P1300D	8B8	U1	V290BJ1-PE1 (Open Cell, CMI)
32P1300D	7B3	G1	LC320DXJ-SFE1 (Open Cell, LG)
39P2300D	9B9	U1	V390HJ1-P02 (Open Cell, CMI)
		W1	T390HVN04.0 SKD (Open Cell, AUO)

TOSHIBA CORPORATION

REV. 00
Jul./24/2013

SCHEMATIC DIAGRAMS

PRODUCT NAME 32P2300 (代表機種)

UNIT NAME LED/REMOTE

PWA NAME _____

PWB NAME PE1127

展開機種
<TJP>
24P2300/29P2300/39P2300
24P1300/29P1300/32P1300

UNIT NO. _____

PWA NO. B910PE1127A1/B1

PWB NO. PE1127A1(P2300)/B1(P1300)

PAGE	FUNCTION	REV	PAGE	FUNCTION	REV
1	Cover	00	26		
2	LED/REMOTE/OPT SENS.	00	27		
3			28		
4			29		
5			30		
6			31		
7			32		
8			33		
9			34		
10			35		
11			36		
12			37		
13			38		
14			39		
15			40		
16			41		
17			42		
18			43		
19			44		
20			45		
21			46		
22			47		
23			48		
24			49		
25			50		

REV. MARK	CONTENTS	APPROVED BY	REVISED BY	REGISTERED
00	New release			

APPROVED BY <p style="text-align: center;">MATSUDA</p>	CHECKED BY	DESIGNED BY <p style="text-align: center;">YAJIMA</p>	TITLE <p style="text-align: center;">LED/RMT BOARD</p>	TOTAL <p style="text-align: center;">2</p>	PAGE NO. <p style="text-align: center;">1</p>	REV. MARK <p style="text-align: center;">00</p>	DRAWING. NO. <p style="text-align: center;">PE1127</p>
---	------------	--	---	---	--	--	---

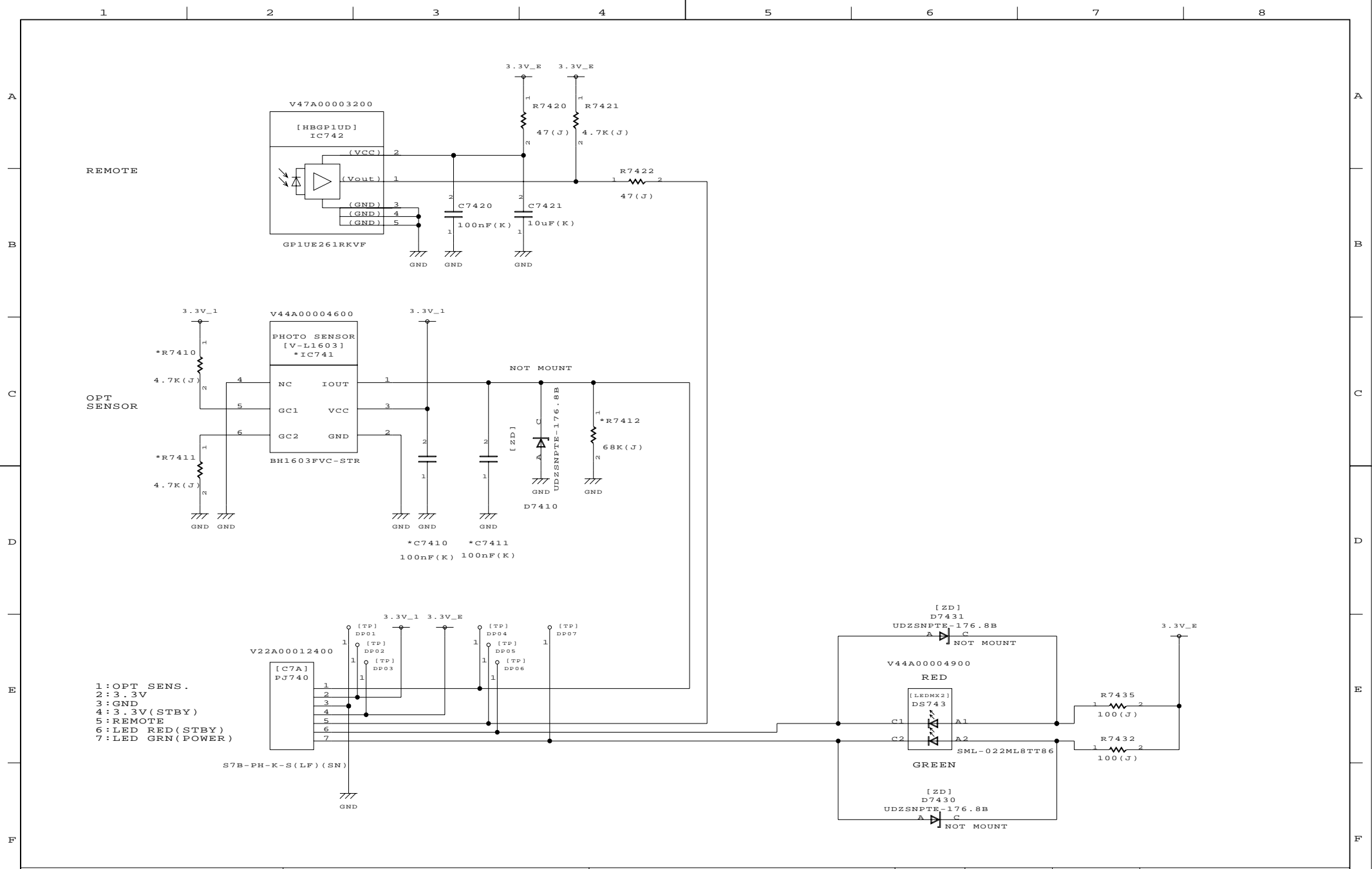

DESIGNED BY YAJIMA	TITLE LED/RMT BOARD	FUNCTION LED/REMOTE/OPT	SH.NO. 100	PAGE NO. 2	REV.MARK 00	DRAWING.NO. PE1127
------------------------------	-------------------------------	-----------------------------------	----------------------	----------------------	-----------------------	------------------------------

SCHEMATIC DIAGRAMS

32P1300

PRODUCT NAME '13 ASEAN ANALOG LCD TV

UNIT NAME MP DPL

PWA NAME _____

PWB NAME PE1129ZA

展開機種
<TJP>
24P1300 29P1300

<TEVP>

UNIT NO. _____

PWA NO. _____

PWB NO. _____

PAGE	SH.	FUNCTION	REV	PAGE	SH.	FUNCTION	REV	PAGE	SH.	FUNCTION	REV	PAGE	SH.	FUNCTION	REV
1	001	Cover		26	750	Tuner		51				76			
2	002	Revision		27	901	SoC 3.3V Power		52				77			
3	101	RTD2648(Analog Video I/F)		28	902	SoC 1.8V Power		53				78			
4	102	RTD2648(Analog Video & IF)		29	903	SoC 1.0V Power		54				79			
5	103	RTD2648(Analog Audio I/F)		30	906	3.3V2 Power		55				80			
6	104	RTD2648(HDMI I/F)		31	907	1.8V2 Power		56				81			
7	105	RTD2648(LVDS I/F)		32	911	VCC LCD		57				82			
8	106	RTD2648(NAND/SPI I/F)		33	912	Power Control		58				83			
9	107	RTD2648(GPIO,USB I/F)		34	950	Main/Power B-B		59				84			
10	108	RTD2648(Peripheral I/F)		35	960	EMC		60				85			
11	109	RTD2648(Power and GND)		36				61				86			
12	110	Flash Memory		37				62				87			
13	111	Debug/Reset		38				63				88			
14	160	USB Connector(side)		39				64				89			
15	301	Audio Mute		40				65				90			
16	370	Audio D-AMP		41				66				91			
17	371	Audio D-AMP out		42				67				92			
18	601	AV Jack		43				68				93			
19	603	Video out (for test)		44				69				94			
20	650	LVDS Connector		45				70				95			
21	660	HDMI Connector		46				71				96			
22	661	HDMI HPD		47				72				97			
23	669	HDCP Key ROM		48				73				98			
24	700	LED/RMT I/F		49				74				99			
25	702	Tack Key I/F		50				75				100			

APPROVED BY	CHECKED BY	DESIGNED BY	TITLE	TOTAL	PAGE NO.	REV. MARK	DRAWING. NO.
MATSUDA	-	SASAKI	Circuit Diagram		01 MP	DPL	PE1129ZA

	1	2	3	4	5	6	7	8			
A	REV. MARK	CONTENTS	APPROVED BY	REVISED BY	REGISTERED	REV. MARK	CONTENTS	APPROVED BY	REVISED BY	REGISTERED	A
	#1	First Release 32P1300 MP DPL (PE1129ZA)	MATSUDA '13/3/6	SASAKI '13/3/6	SASAKI '13/3/6						
B											B
C											C
D											D
E											E
F											F

DESIGNED BY SASAKI	@Date 2013.03.06 17:05	TITLE Circuit Diagram	FUNCTION REVISION SHEET	SH.NO. 002	PAGE NO. 02	REV.MARK MP DPL	DRAWING.NO. PE1129ZA
-----------------------	---------------------------	--------------------------	----------------------------	---------------	----------------	--------------------	-------------------------

1 2 3 4 5 6 7 8

A
B
C
D
E
F

A
B
C
D
E
F

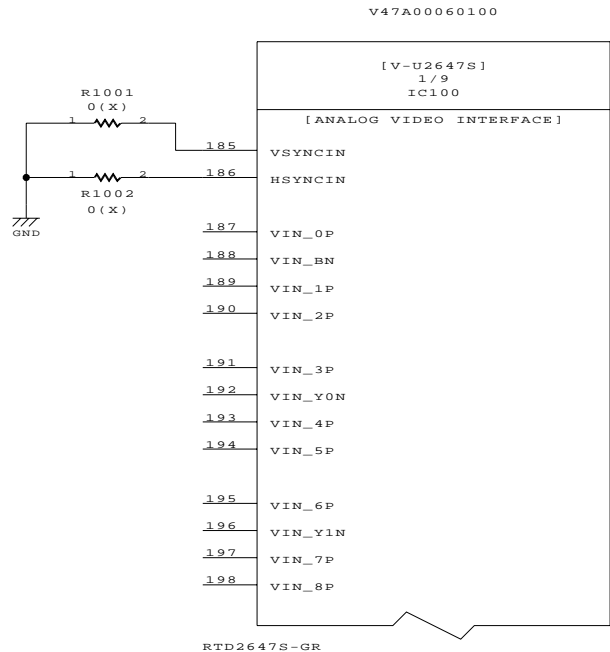

DESIGNED BY SEKIGUCHI	TITLE 24/29/32P1300	FUNCTION RTD2647(Analog Video I/F)	SH.NO. 101	PAGE NO. 03	REV.MARK MP DPL	DRAWING.NO. PE1129ZA
--------------------------	------------------------	---------------------------------------	---------------	----------------	--------------------	-------------------------

2013.03.06 17:05

TOSHIBA CORPORATION

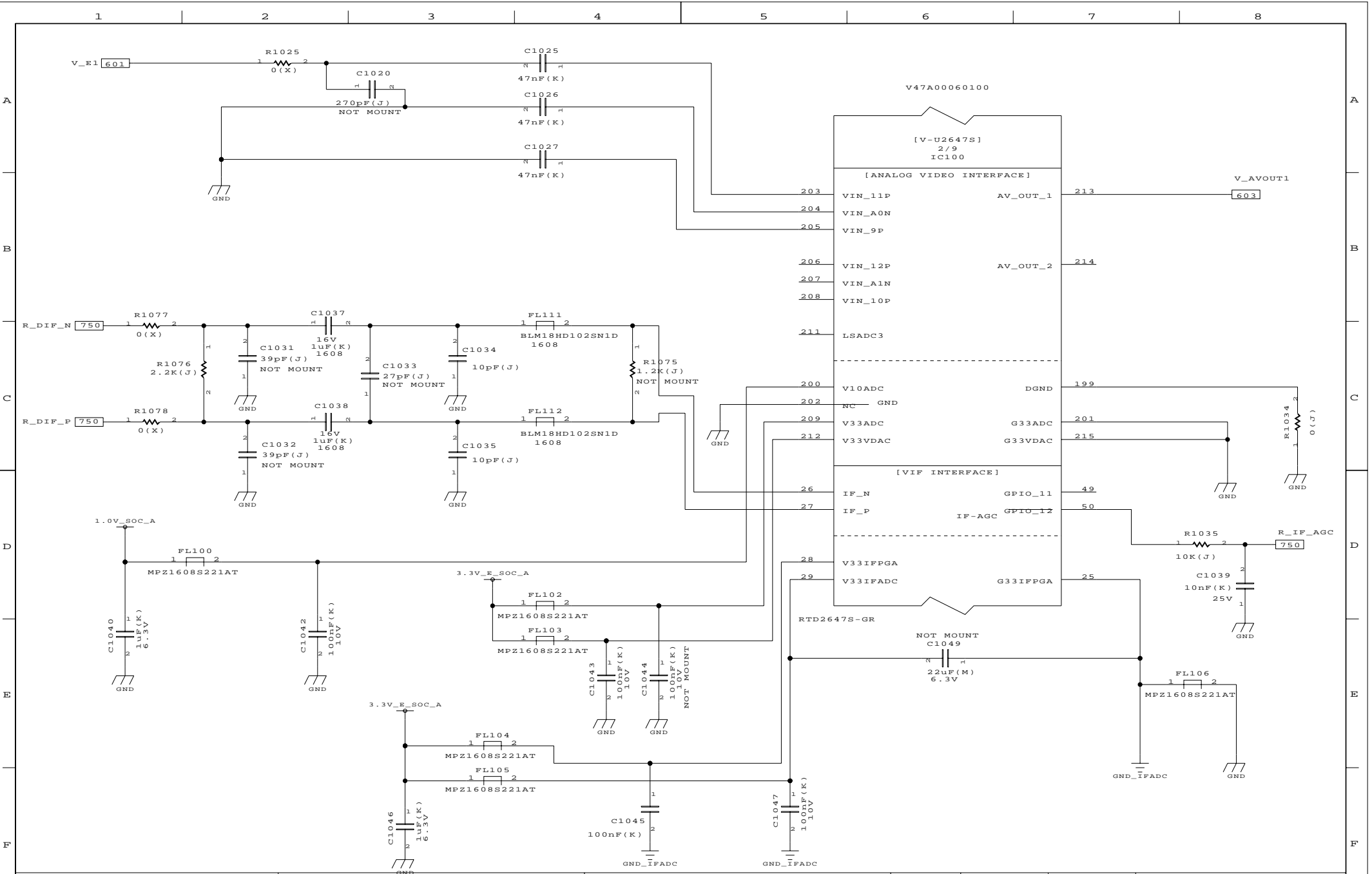

DESIGNED BY	TITLE	FUNCTION	SH.NO.	PAGE NO.	REV.MARK	DRAWING.NO.
SEKIGUCHI/KAWANABE	24/29/32P1300	RTD2647(Analog Video & IF)	102	04	MP DPL	PE1129ZA

2013.03.06 17:05

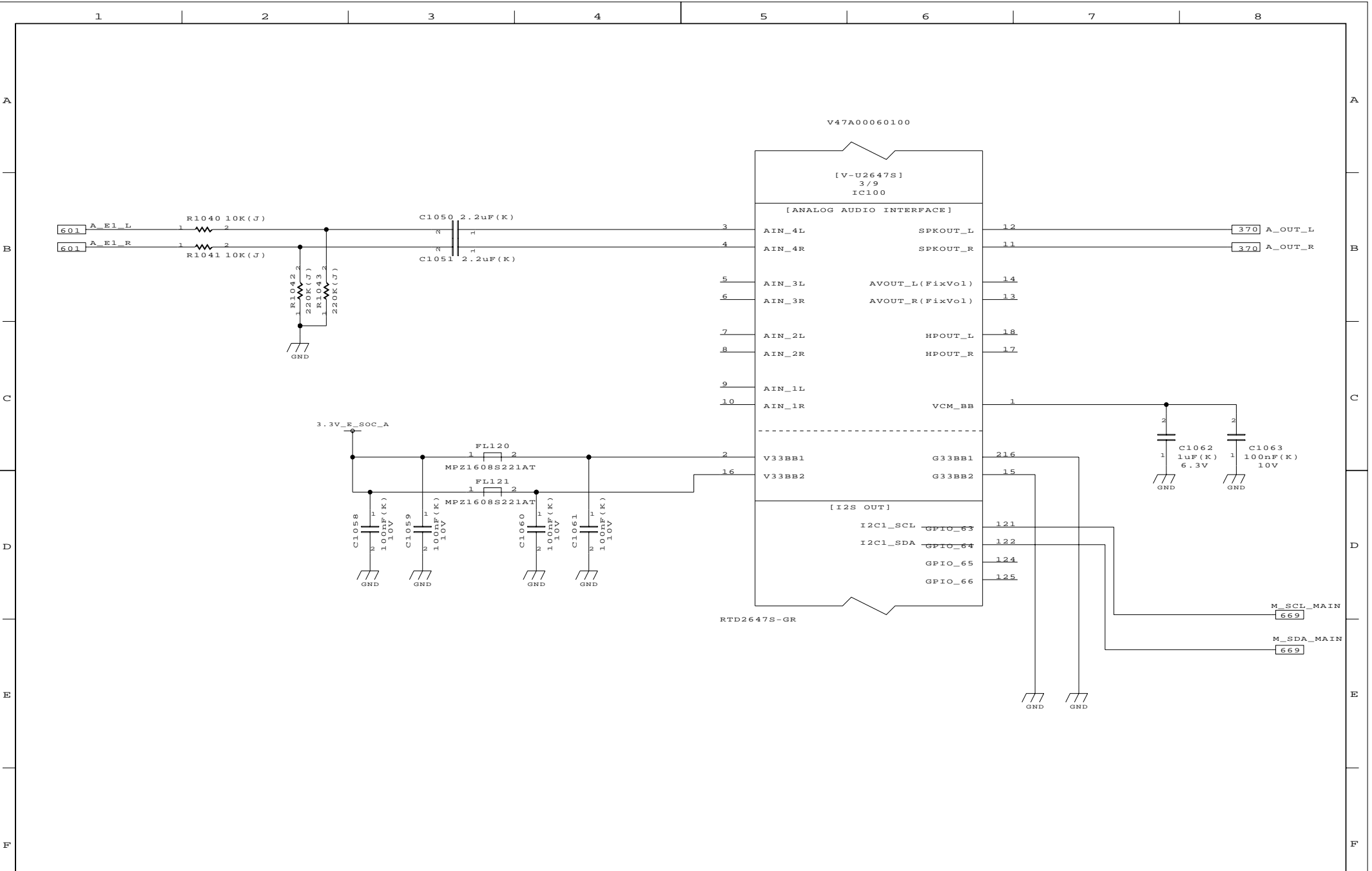

DESIGNED BY MORISHITA	TITLE 24/29/32P1300	FUNCTION RTD2647(Analog Audio I/F)	SH.NO. 103	PAGE NO. 05	REV.MARK MP DPL	DRAWING.NO. PE1129ZA
--------------------------	------------------------	---------------------------------------	---------------	----------------	--------------------	-------------------------

2013.03.0617:05

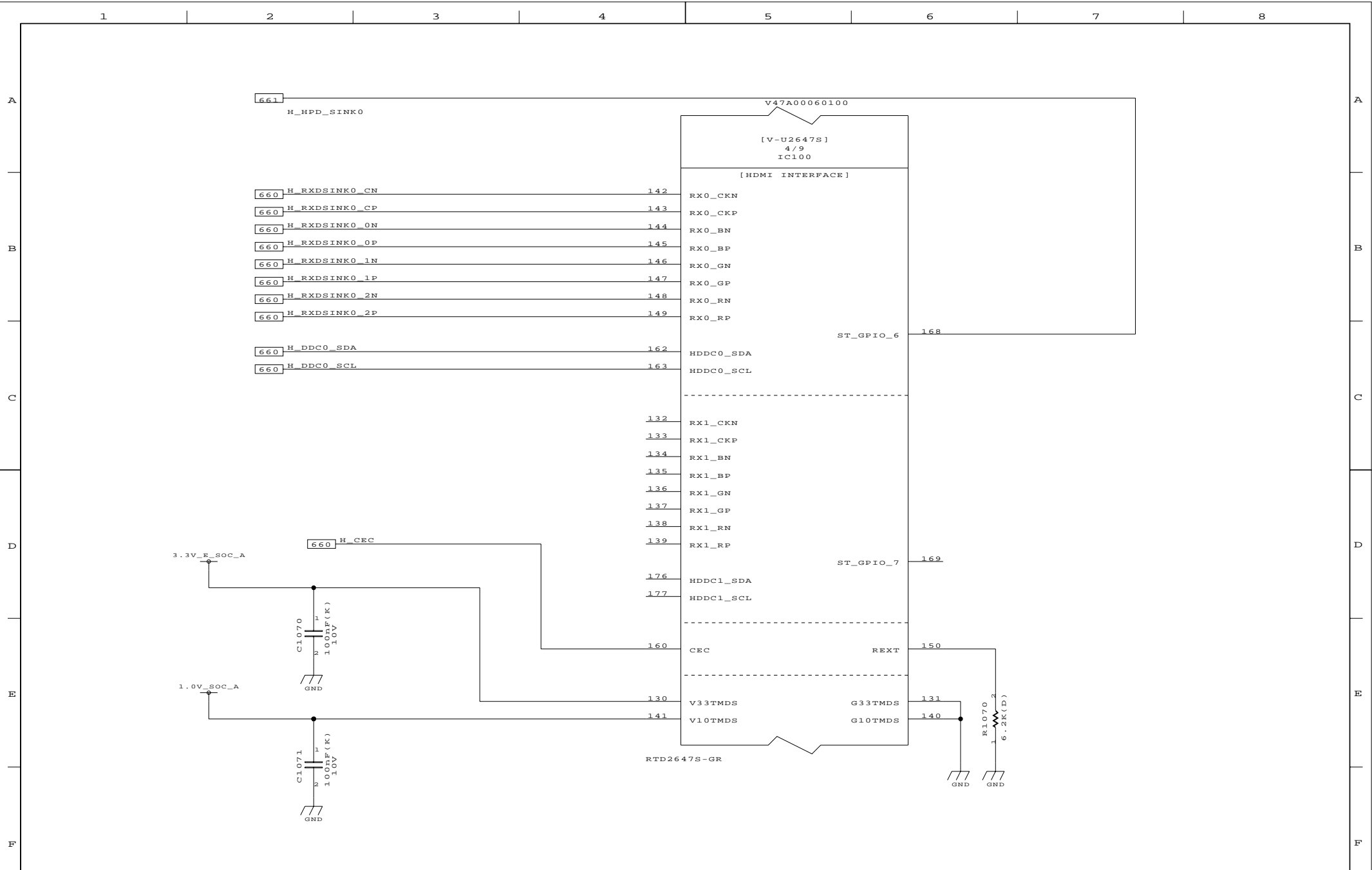

DESIGNED BY	TITLE	FUNCTION	SH.NO.	PAGE NO.	REV.MARK	DRAWING.NO.
NAMIKAWA	24/29/32P1300	RTD2647 (HDMI I/F)	104	06	MP DPL	PE1129ZA

2013.03.06 17:05

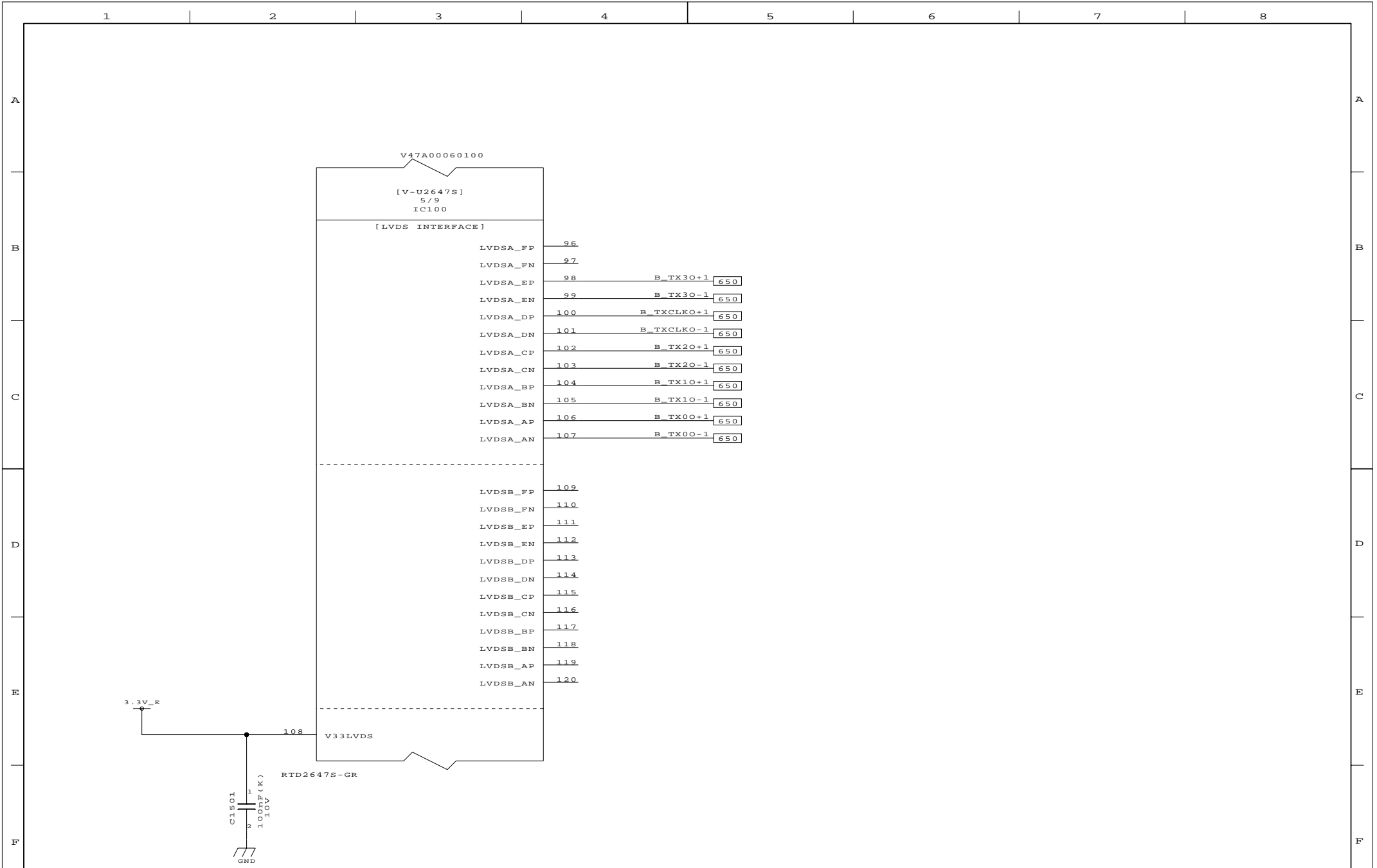

DESIGNED BY IKEHARA	TITLE 24/29/32P1300	FUNCTION RTD2647(LVDS I/F)	SH.NO. 105	PAGE NO. 07	REV.MARK MP DPL	DRAWING.NO. PE1129ZA
------------------------	------------------------	-------------------------------	---------------	----------------	--------------------	-------------------------

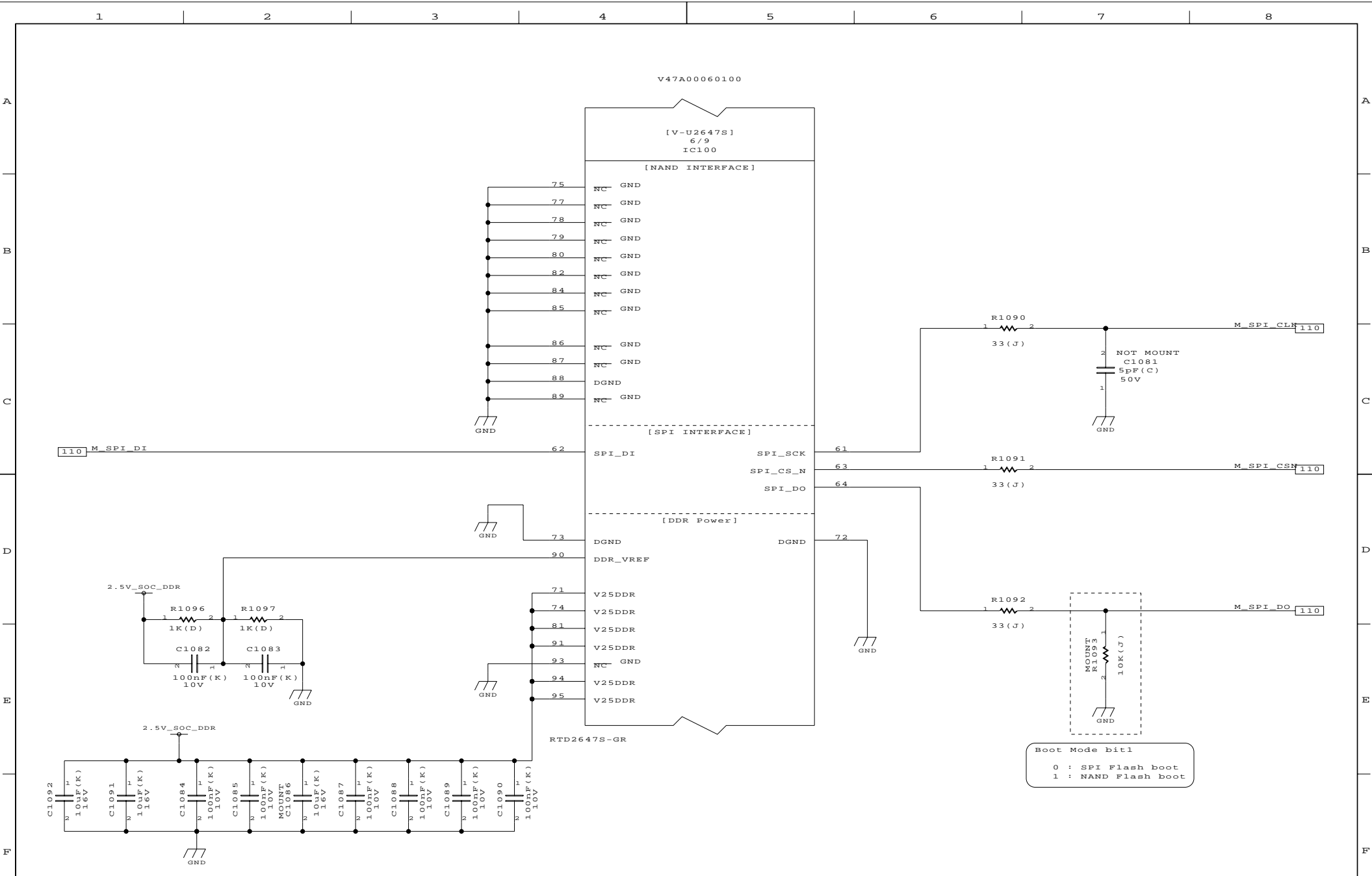

Boot Mode bit1
 0 : SPI Flash boot
 1 : NAND Flash boot

DESIGNED BY SASAKI	TITLE 24/29/32P1300	FUNCTION RTD2647(NAND/SPI I/F)	SH.NO. 106	PAGE NO. 08	REV.MARK MP DPL	DRAWING.NO. PE1129ZA
------------------------------	-------------------------------	--	----------------------	-----------------------	---------------------------	--------------------------------

2013.03.06 17:05

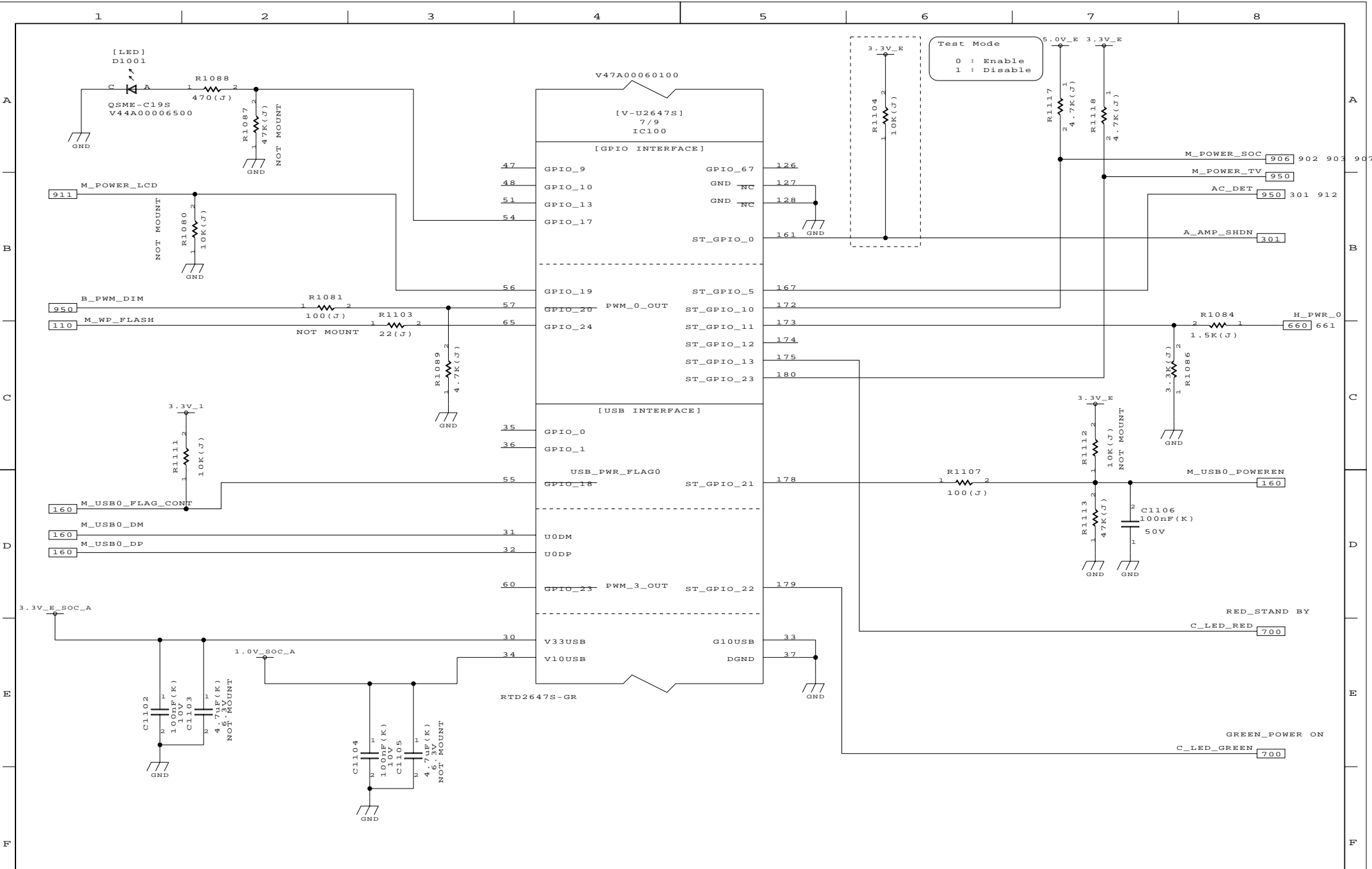

DESIGNED BY SASAKI	TITLE 24/29/32P1300	FUNCTION RTD2647(GPIO,USB I/F)	SH.NO. 107	PAGE NO. 09	REV.MARK MP DPL	DRAWING.NO. PE1129ZA
------------------------------	-------------------------------	--	----------------------	-----------------------	---------------------------	--------------------------------

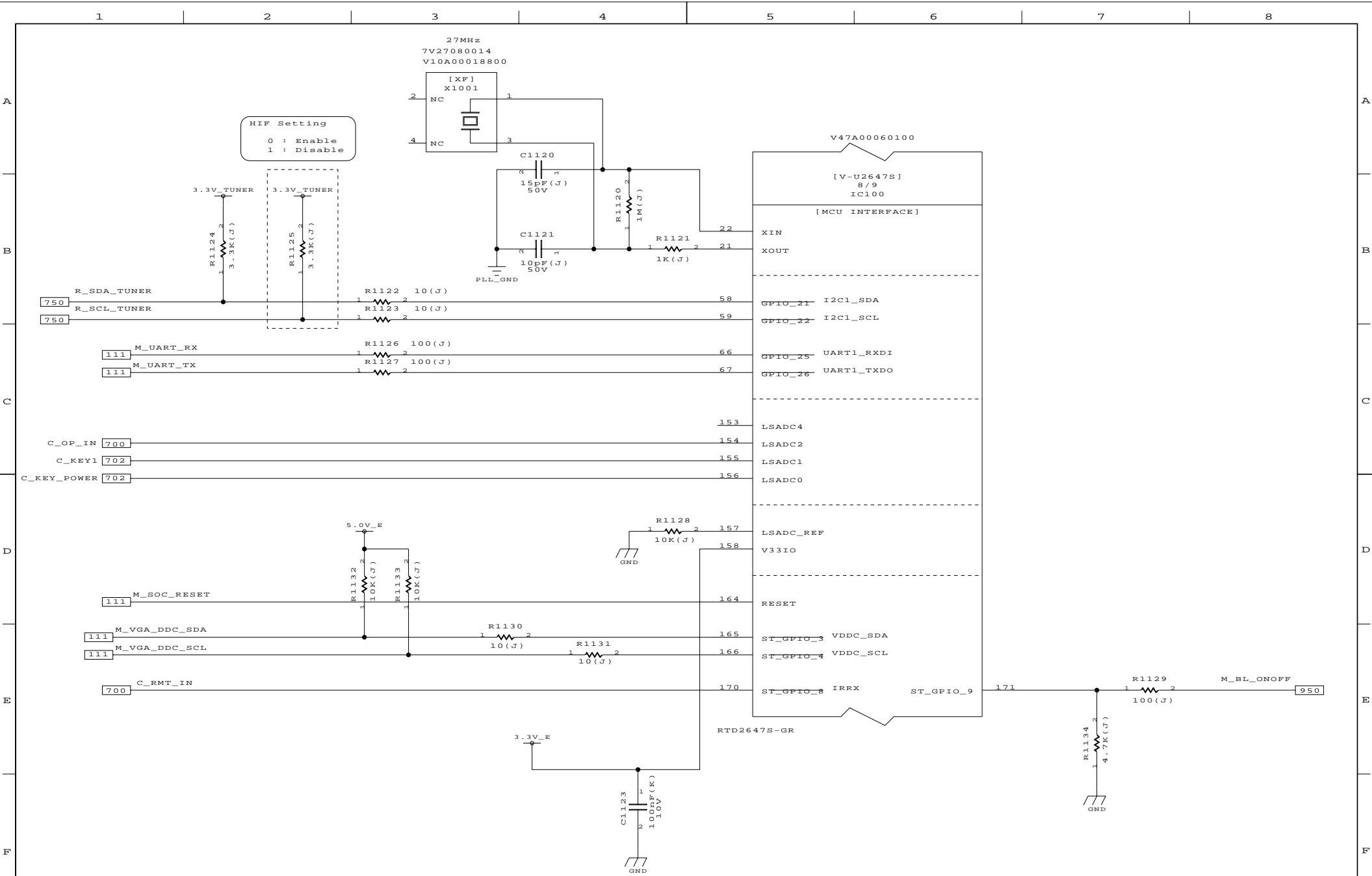

DESIGNED BY SASAKI	TITLE 24/29/32P1300	FUNCTION RTD2647(Periferal I/F)	SH.NO. 108	PAGE NO. 10	REV.MARK MP DPL	DRAWING.NO. PE1129ZA
------------------------------	-------------------------------	---	----------------------	-----------------------	---------------------------	--------------------------------

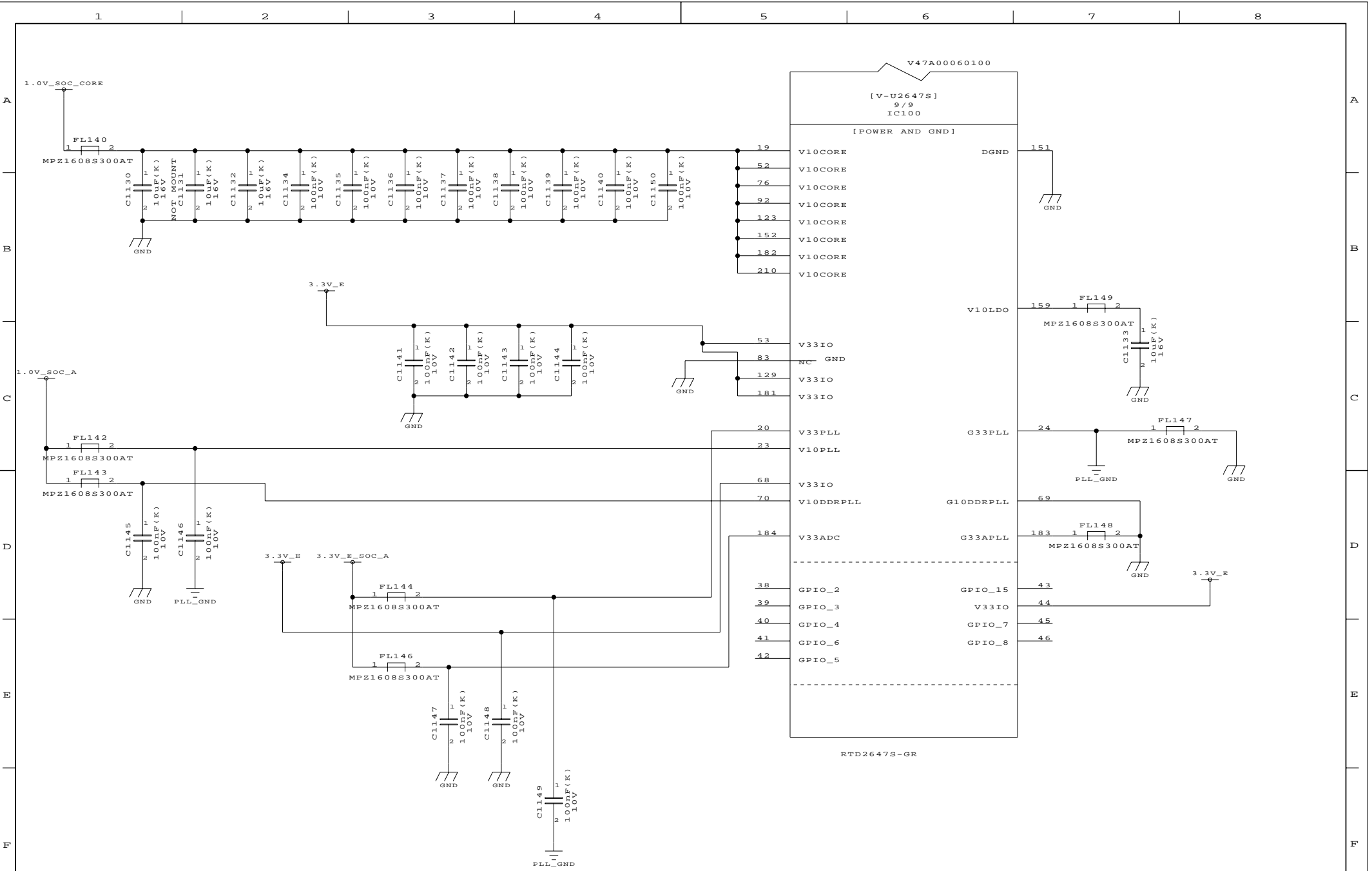

DESIGNED BY	TITLE	FUNCTION	SH.NO.	PAGE NO.	REV.MARK	DRAWING.NO.
SASAKI	24/29/32P1300	RTD2647 (Power & GND)	109	11	MP DPL	PE1129ZA

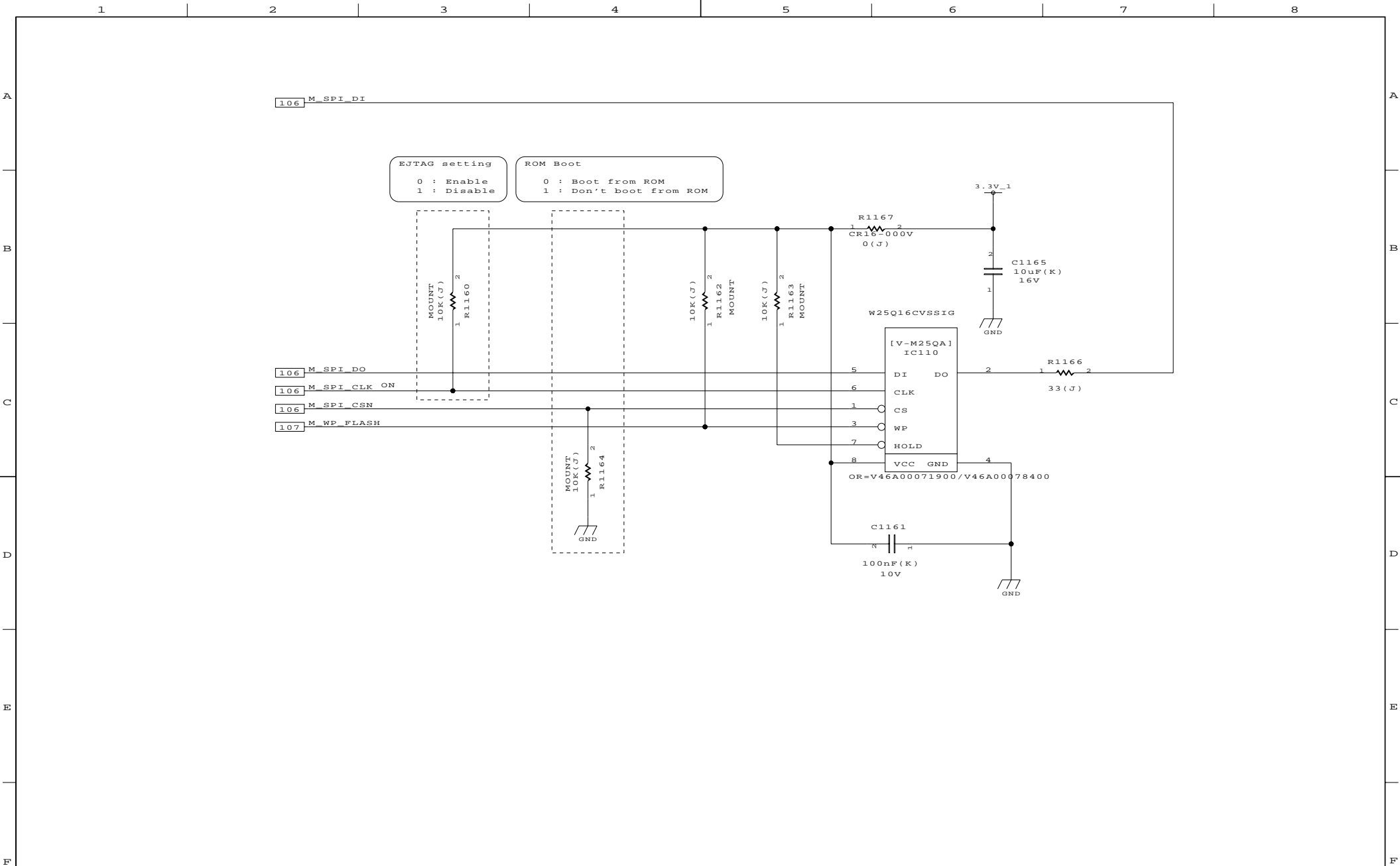

DESIGNED BY WATANABE/SASAKI	TITLE 24/29/32P1300	FUNCTION Flash Memory	SH.NO. 110	PAGE NO. 12	REV.MARK MP DPL	DRAWING.NO. PE1129ZA
---------------------------------------	-------------------------------	---------------------------------	----------------------	-----------------------	---------------------------	--------------------------------

1 2 3 4 5 6 7 8

A

B

C

D

E

F

A

B

C

D

E

F

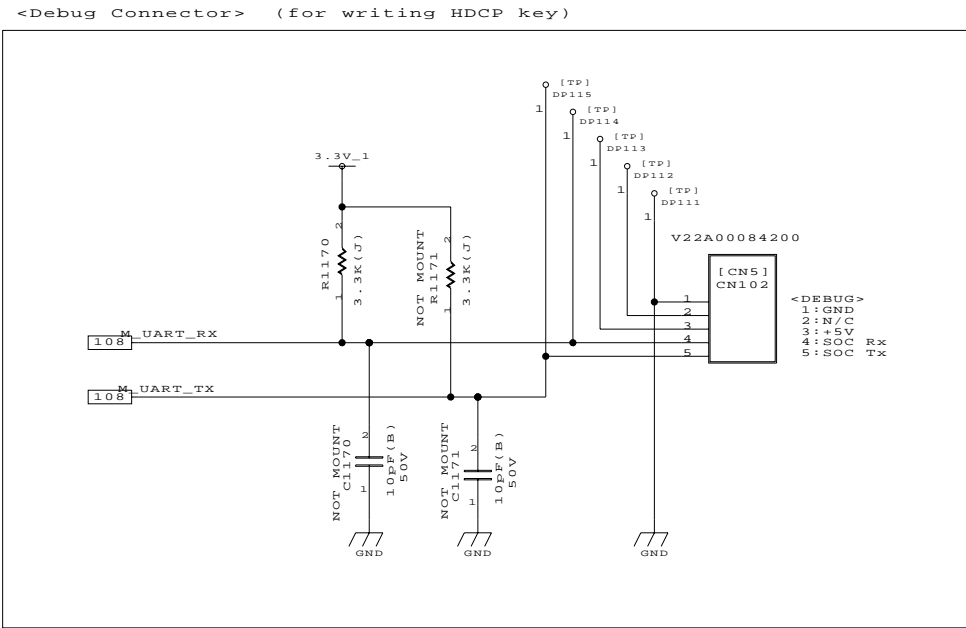

<Reset Circuit>

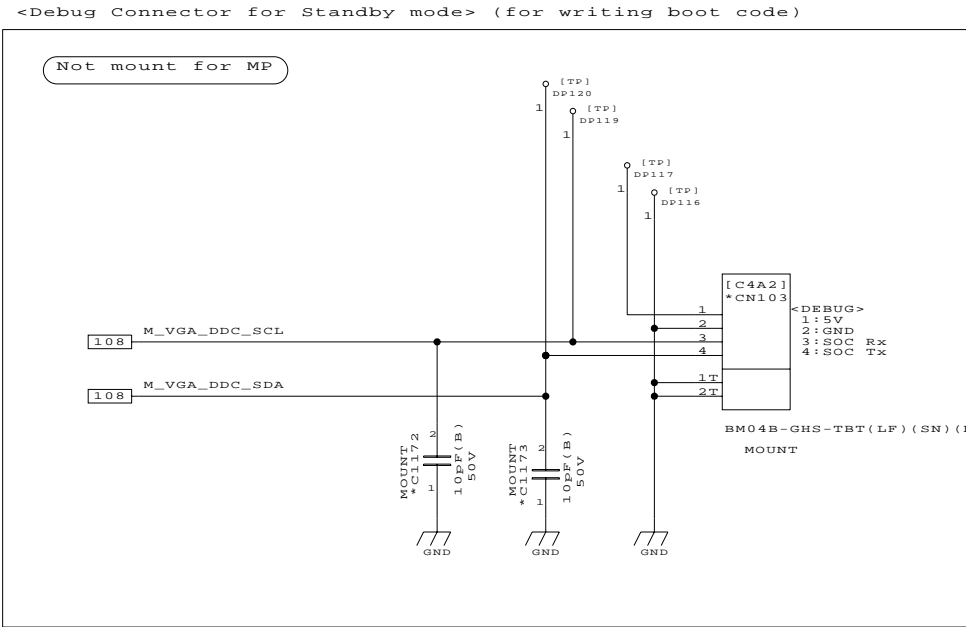
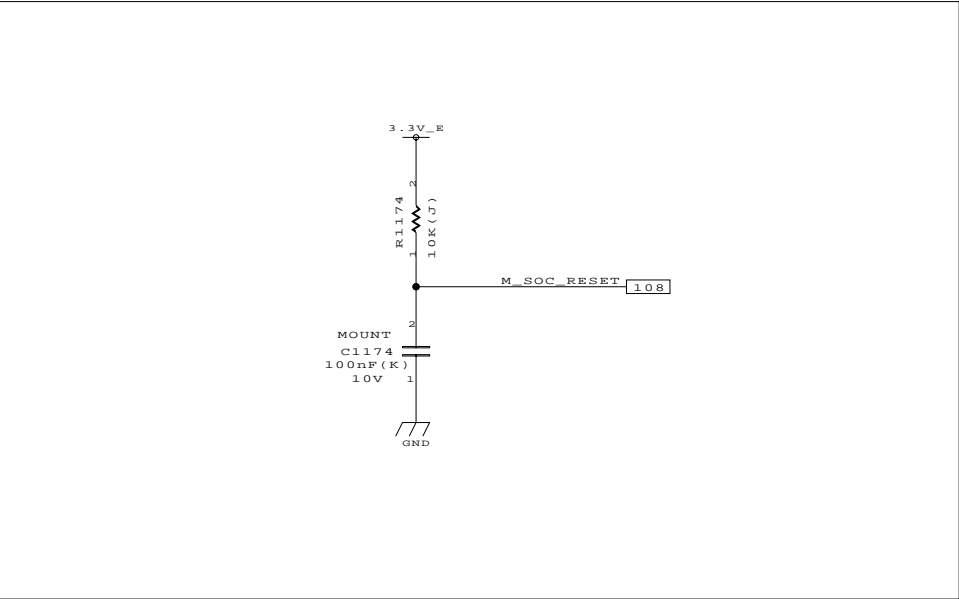

DESIGNED BY	TITLE	FUNCTION	SH.NO.	PAGE NO.	REV.MARK	DRAWING.NO.
SASAKI	24/29/32P1300	Debug/Reset	111	13	MP DPL	PE1129ZA

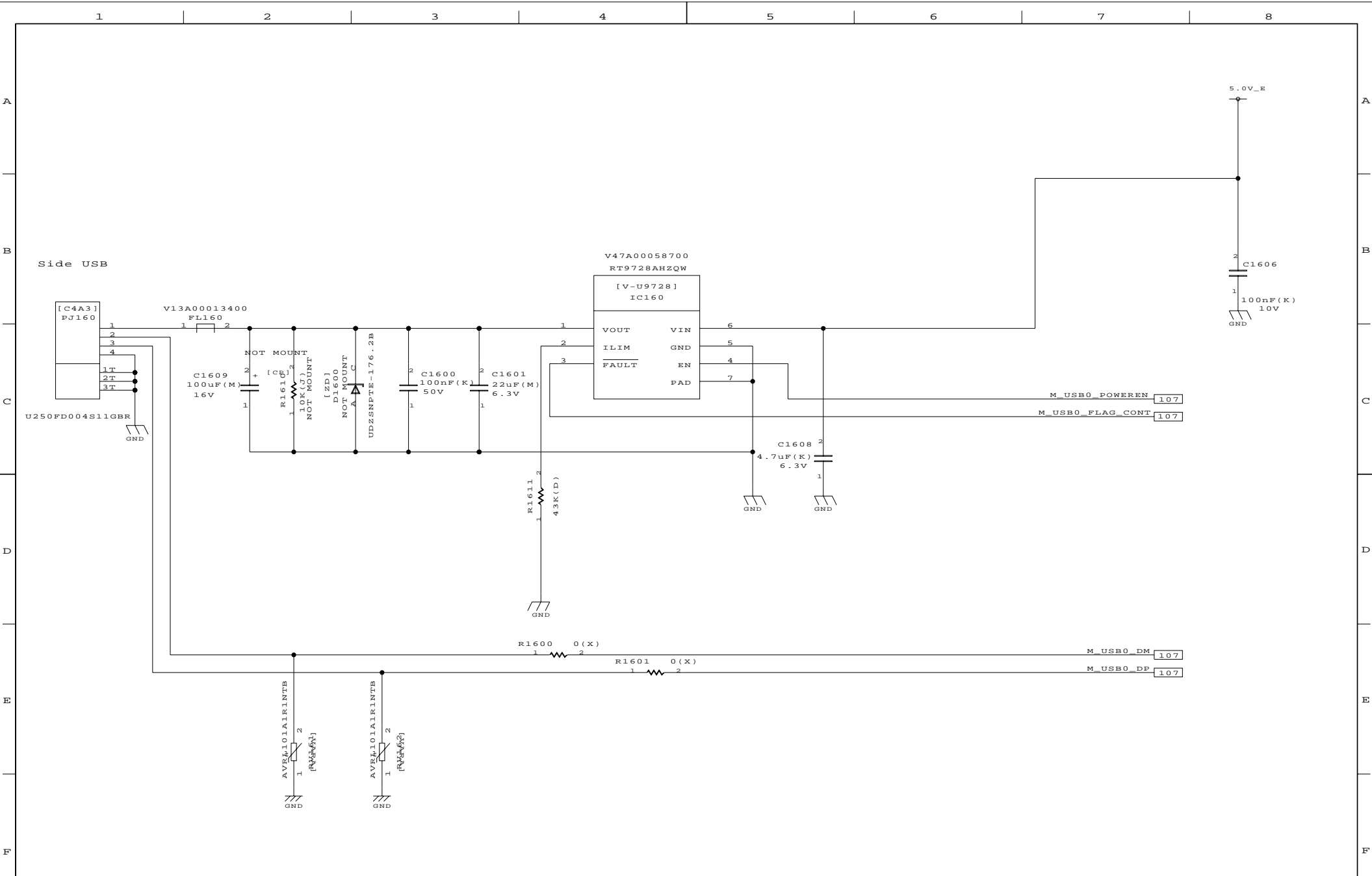

DESIGNED BY SASAKI	TITLE 24/29/32P1300	FUNCTION USB Connector(side)	SH.NO. 160	PAGE NO. 15	REV.MARK MP DPL	DRAWING.NO. PE1129ZA
------------------------------	-------------------------------	--	----------------------	-----------------------	---------------------------	--------------------------------

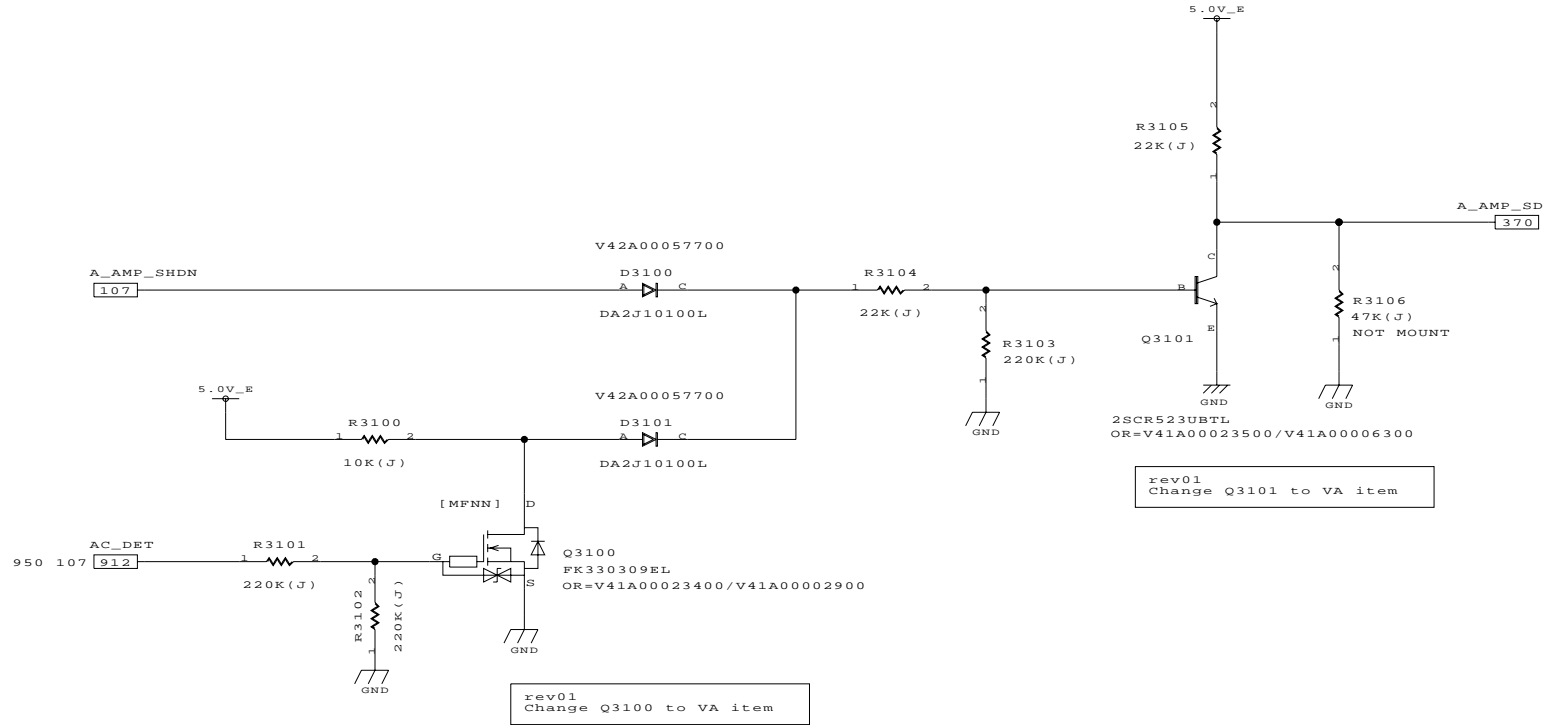

DESIGNED BY	2013/03/06	TITLE	FUNCTION	SH.NO.	PAGE NO.	REV.MARK	DRAWING.NO.
MORISHITA		24/29/32P1300	AUDIO MUTE	301	16	MP DPL	PE1129ZA

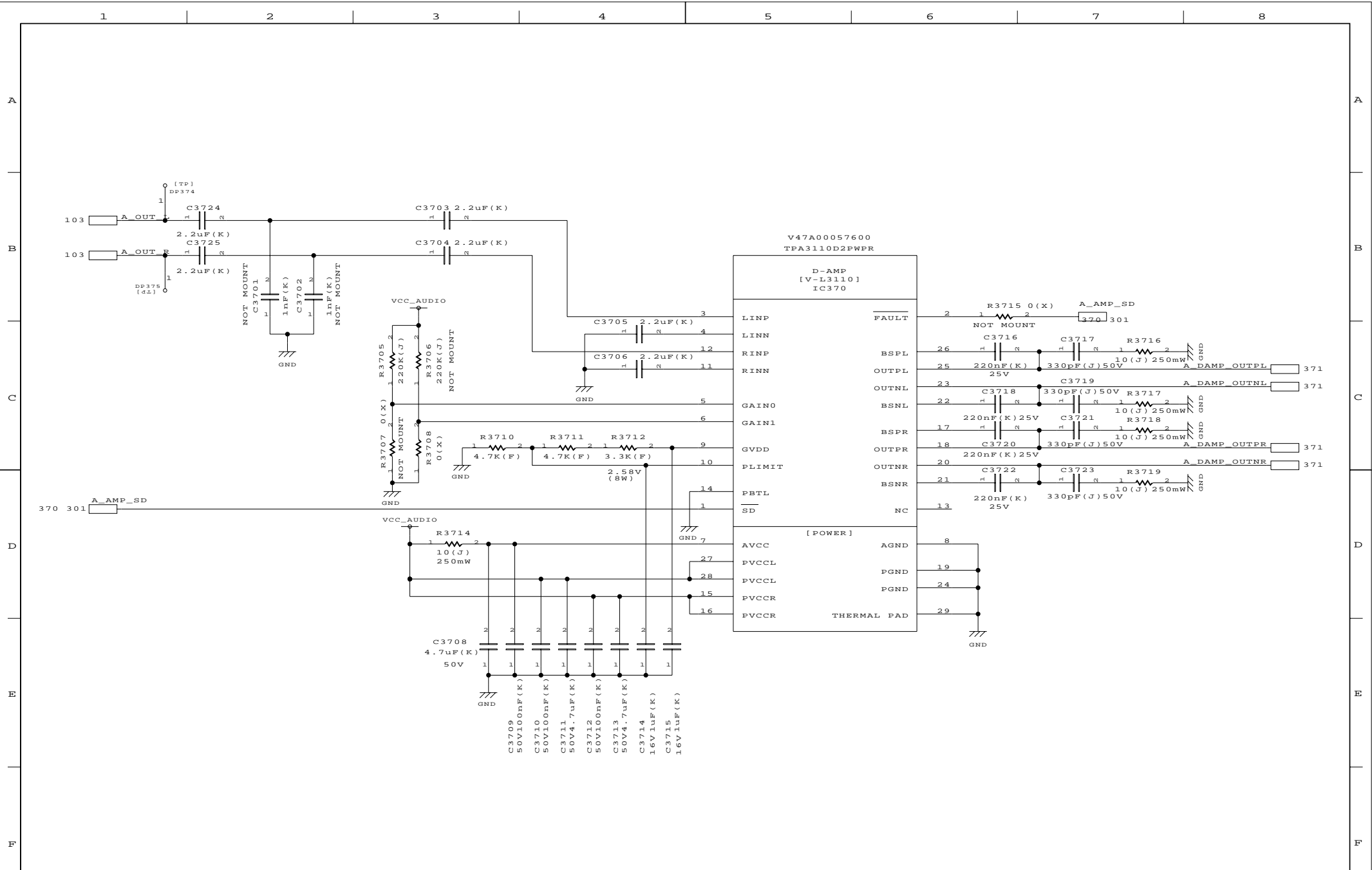

DESIGNED BY	TITLE	FUNCTION	SH.NO.	PAGE NO.	REV.MARK	DRAWING.NO.
MORISHITA	24/29/32P1300	AUDIO D-AMP	370	18	MP DPL	PE1129ZA

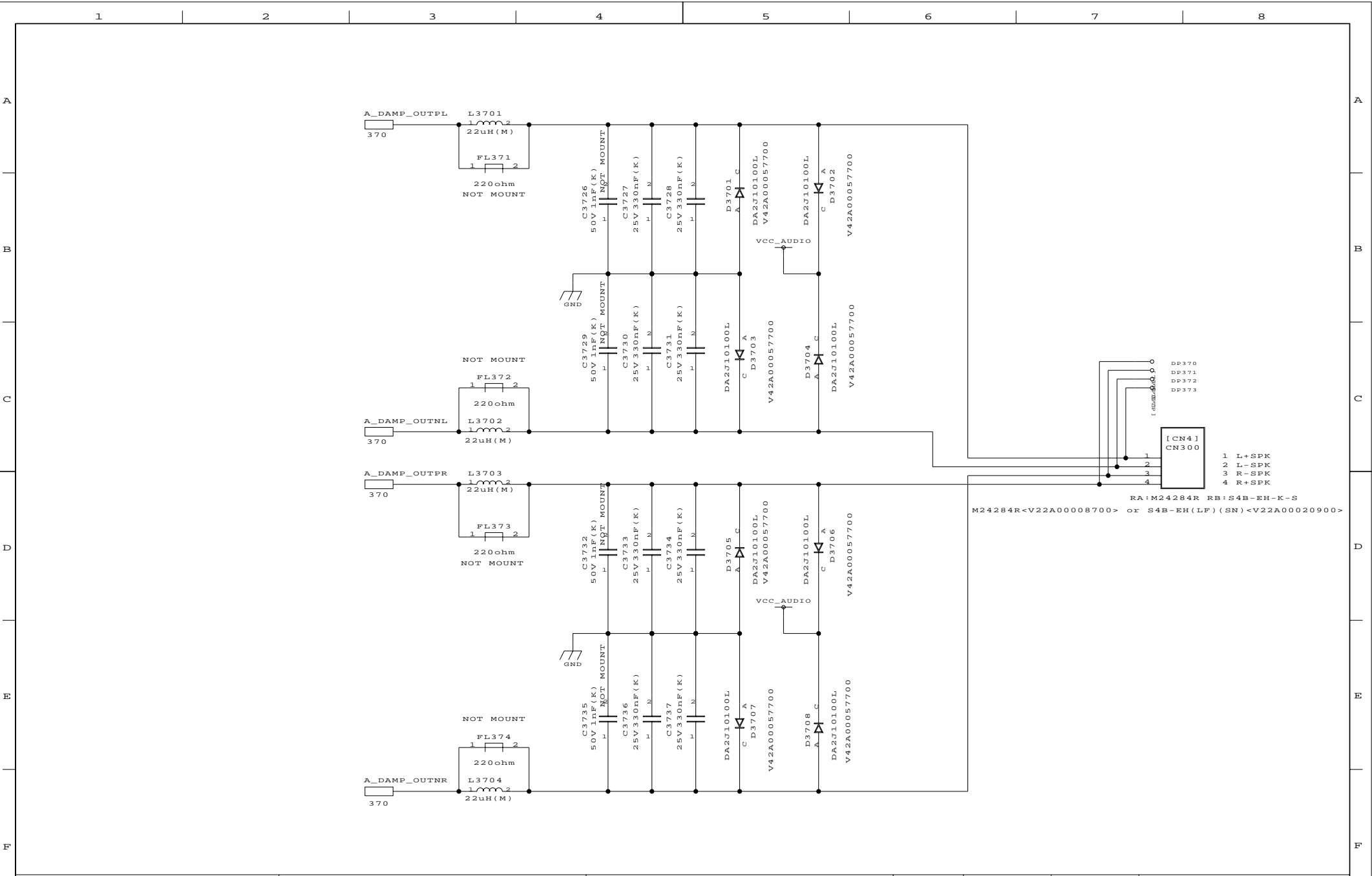

DESIGNED BY	TITLE	FUNCTION	SH.NO.	PAGE NO.	REV.MARK	DRAWING.NO.
MORISHITA	24/29/32P1300	AUDIO D-AMP OUT	371	19	MP DPL	PE1129ZA

2013.03.06 17:06

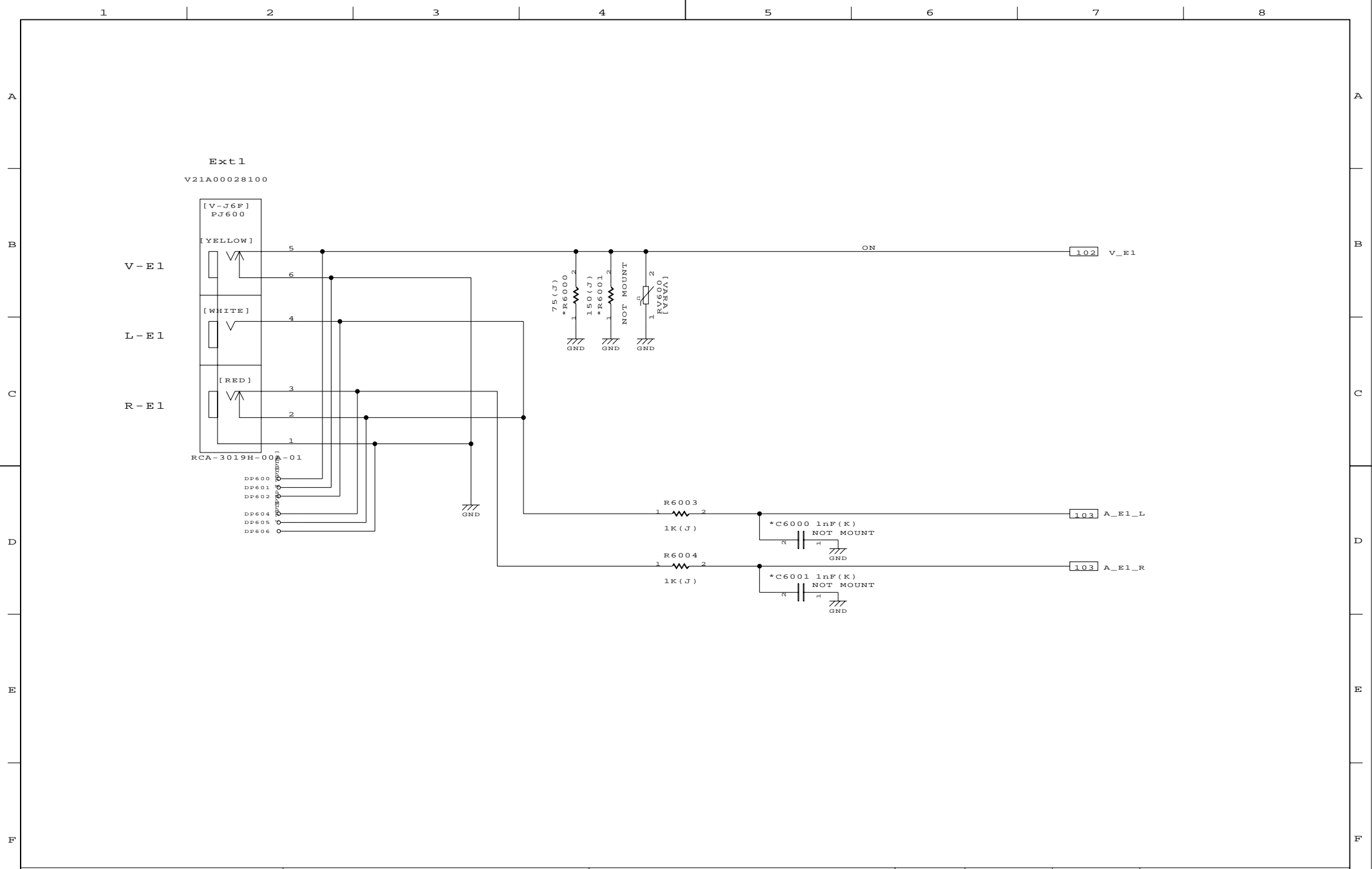

DESIGNED BY SEKIGUCHI/KAWANABE	TITLE 24/29/32P1300	FUNCTION AV Jack	SH.NO. 601	PAGE NO. 20	REV.MARK MP DPL	DRAWING.NO. PE1129ZA
-----------------------------------	------------------------	---------------------	---------------	----------------	--------------------	-------------------------

1 2 3 4 5 6 7 8

A

A

B

B

C

C

D

D

E

E

F

F

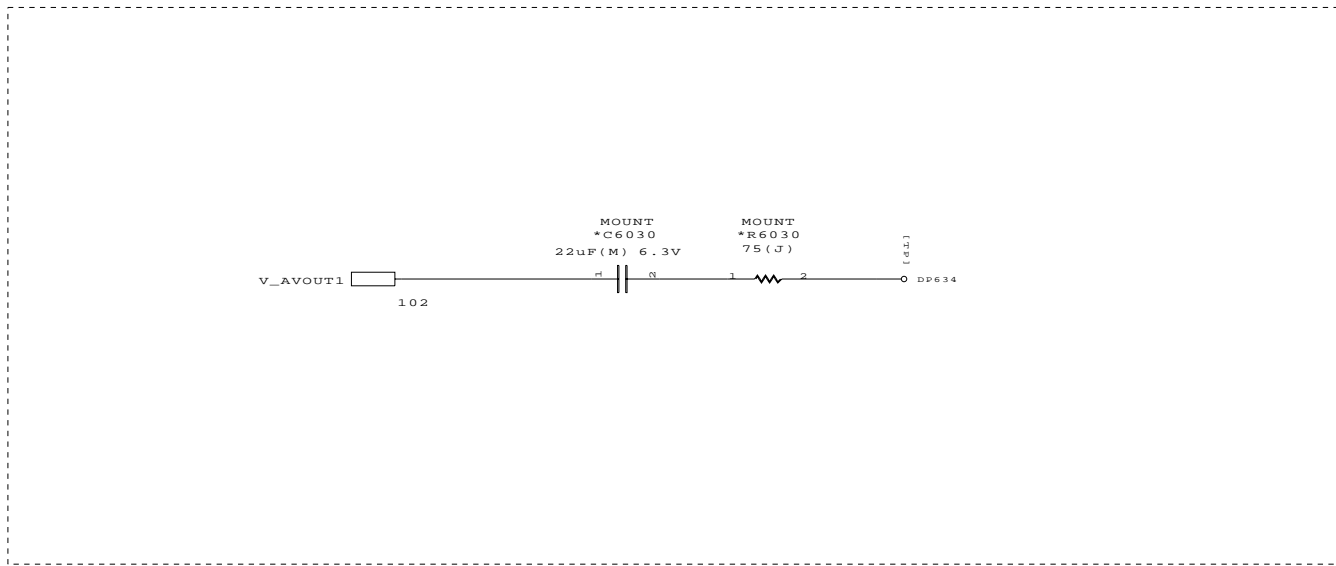

DESIGNED BY

SEKIGUCHI

TITLE

24/29/32P1300

FUNCTION

Video OUT(for TEST)

SH.NO.

603

PAGE NO.

21

REV.MARK

MP DPL

DRAWING.NO.

PE1129ZA

CN650の挿入口には、
部品を配置しない。

Mount resistor for P1300 series

RM651, RM652, RM653	
24/29/32P1300	V01A00113500
29/32P1300D	V13A00021500

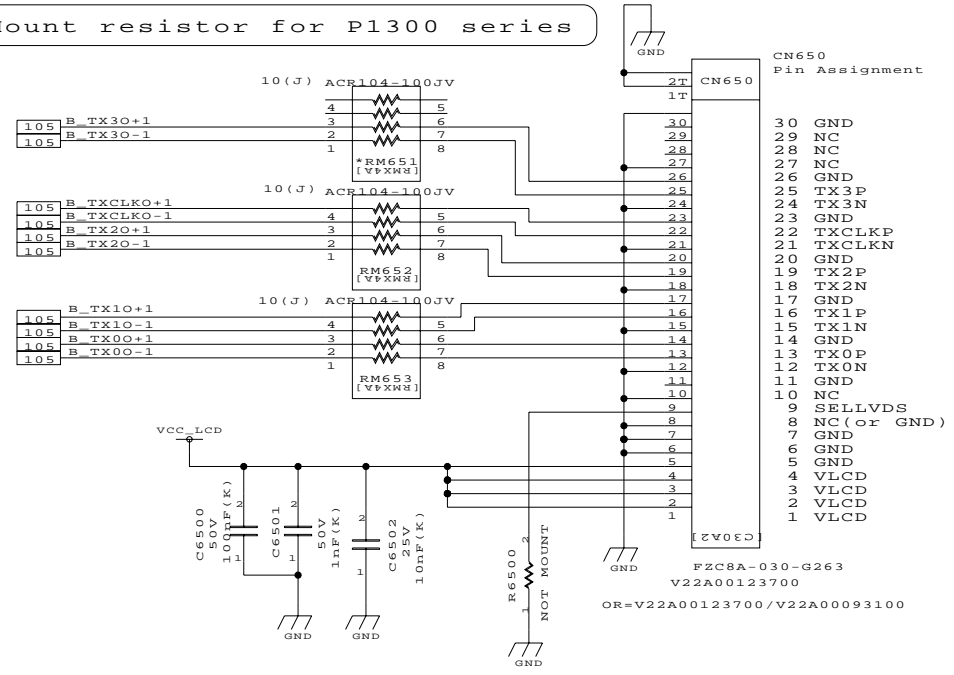

CN650
Pin Assignment

30	GND
29	NC
28	NC
27	NC
26	GND
25	TX3P
24	TX3N
23	GND
22	TXCLKP
21	TXCLKN
20	GND
19	TX2P
18	TX2N
17	GND
16	TX1P
15	TX1N
14	GND
13	TX0P
12	TX0N
11	GND
10	NC
9	SEL LVDS
8	NC (or GND)
7	GND
6	GND
5	GND
4	VLCD
3	VLCD
2	VLCD
1	VLCD

- 24P1300
- 29P1300
- 32P1300
- 29P1300D
- 32P1300D

DESIGNED BY IKEHARA	TITLE 24/29/32P1300	FUNCTION LVDS Connector	SH.NO. 650	PAGE NO. 23	REV.MARK MP DPL	DRAWING.NO. PE1129ZA
------------------------	------------------------	----------------------------	---------------	----------------	--------------------	-------------------------

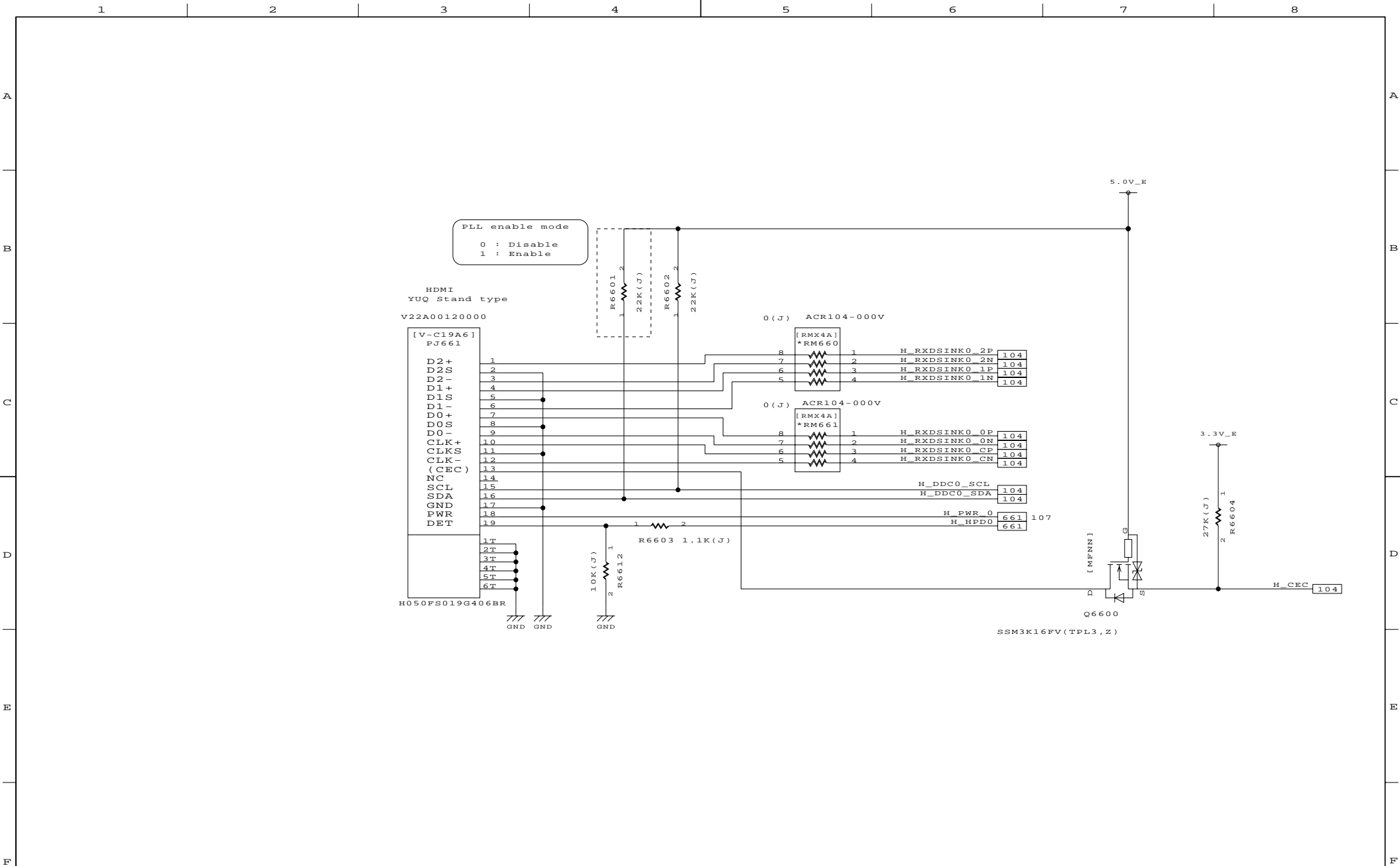

DESIGNED BY NAMIKAWA	TITLE 24/29/32P1300	FUNCTION HDMI Connector	SH.NO. 660	PAGE NO. 24	REV.MARK MP DPL	DRAWING.NO. PE1129ZA
-------------------------	------------------------	----------------------------	---------------	----------------	--------------------	-------------------------

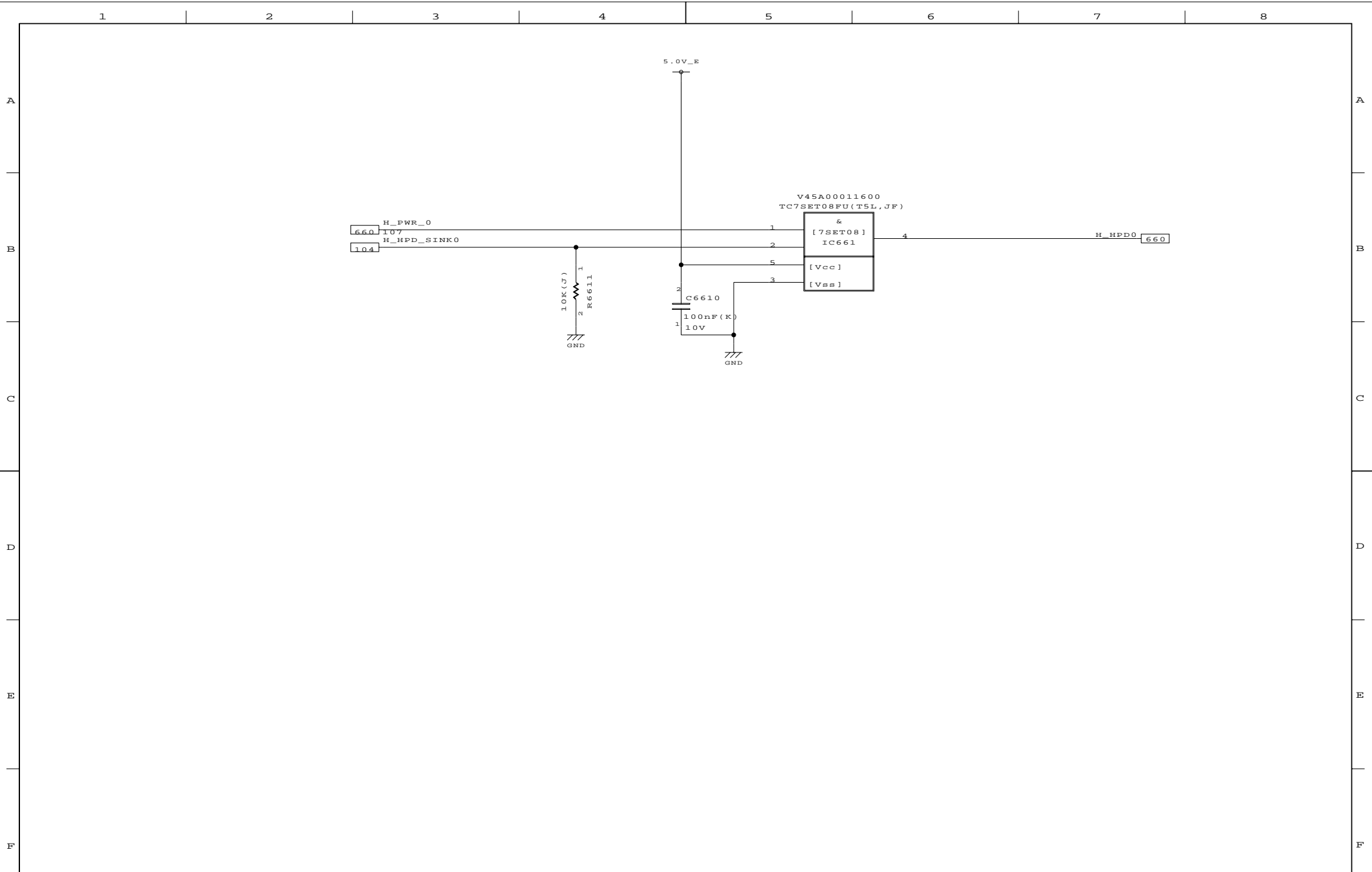

DESIGNED BY NAMIKAWA	TITLE 24/29/32P1300	FUNCTION HDMI HPD	SH.NO. 661	PAGE NO. 25	REV.MARK MP DPL	DRAWING.NO. PE1129ZA
-------------------------	------------------------	----------------------	---------------	----------------	--------------------	-------------------------

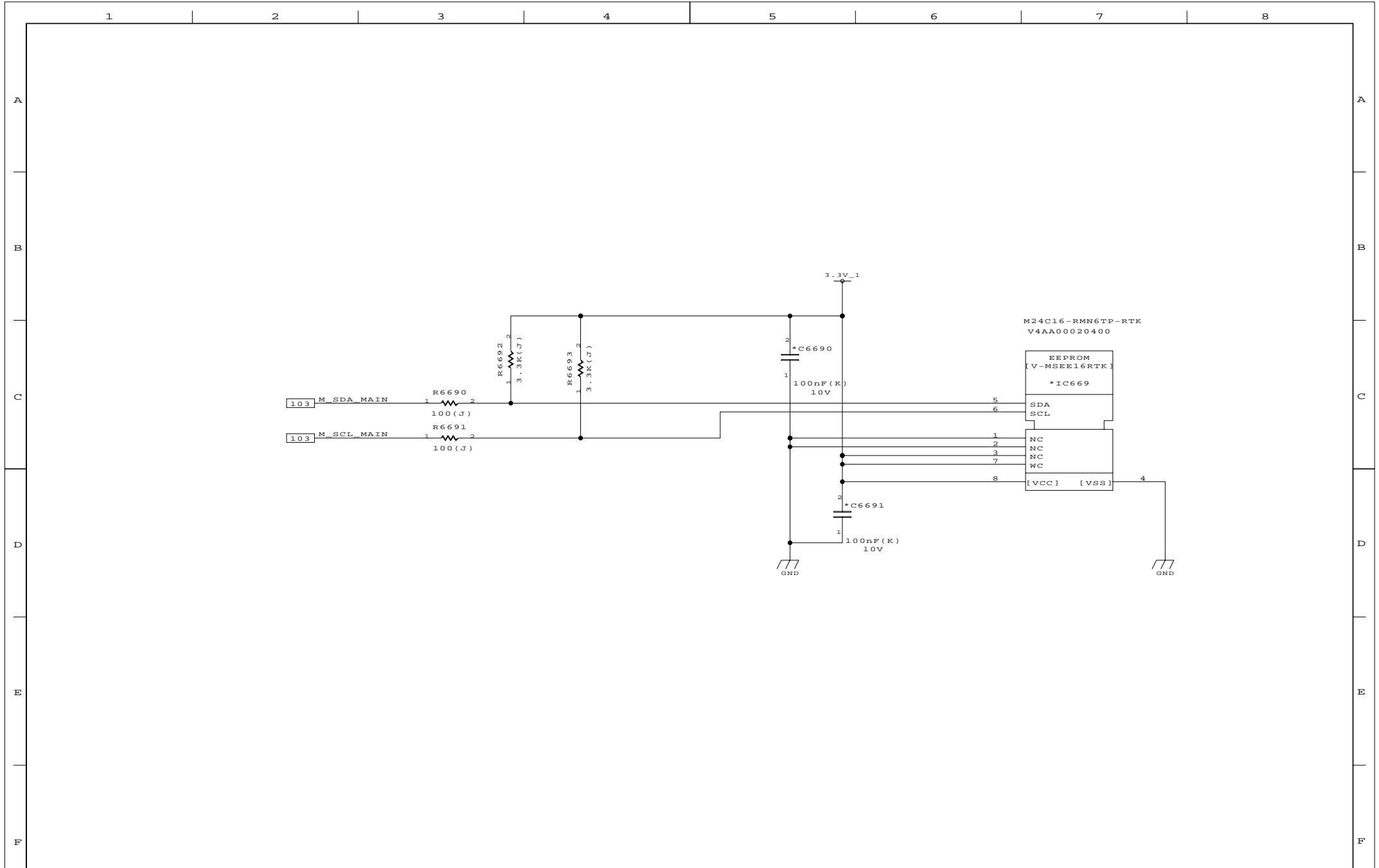

DESIGNED BY NAMIKAWA	TITLE 24/29/32P1300	FUNCTION HDPC KEY ROM	SH.NO. 669	PAGE NO. 26	REV.MARK MP DPL	DRAWING.NO. PE1129ZA
-------------------------	------------------------	--------------------------	---------------	----------------	--------------------	-------------------------

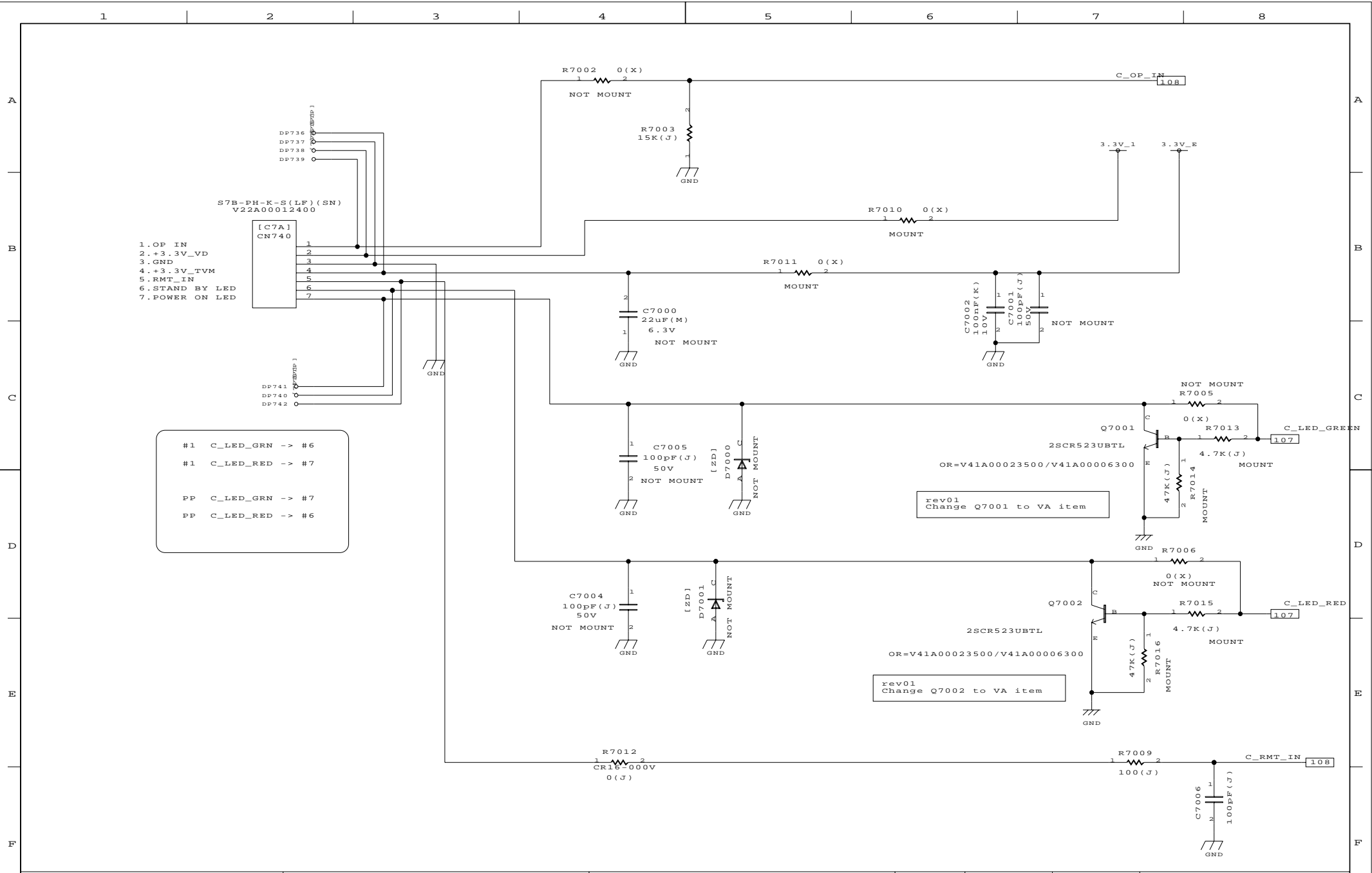

- 1. OP_IN
- 2. +3.3V_VD
- 3. GND
- 4. +3.3V_TVM
- 5. RMT_IN
- 6. STAND BY LED
- 7. POWER ON LED

#1 C_LED_GRN -> #6
 #1 C_LED_RED -> #7
 PP C_LED_GRN -> #7
 PP C_LED_RED -> #6

DESIGNED BY SASAKI	TITLE 24/29/32P1300	FUNCTION LED/RMT I/F	SH.NO. 700	PAGE NO. 27	REV.MARK MP DPL	DRAWING.NO. PE1129ZA
------------------------------	-------------------------------	--------------------------------	----------------------	-----------------------	---------------------------	--------------------------------

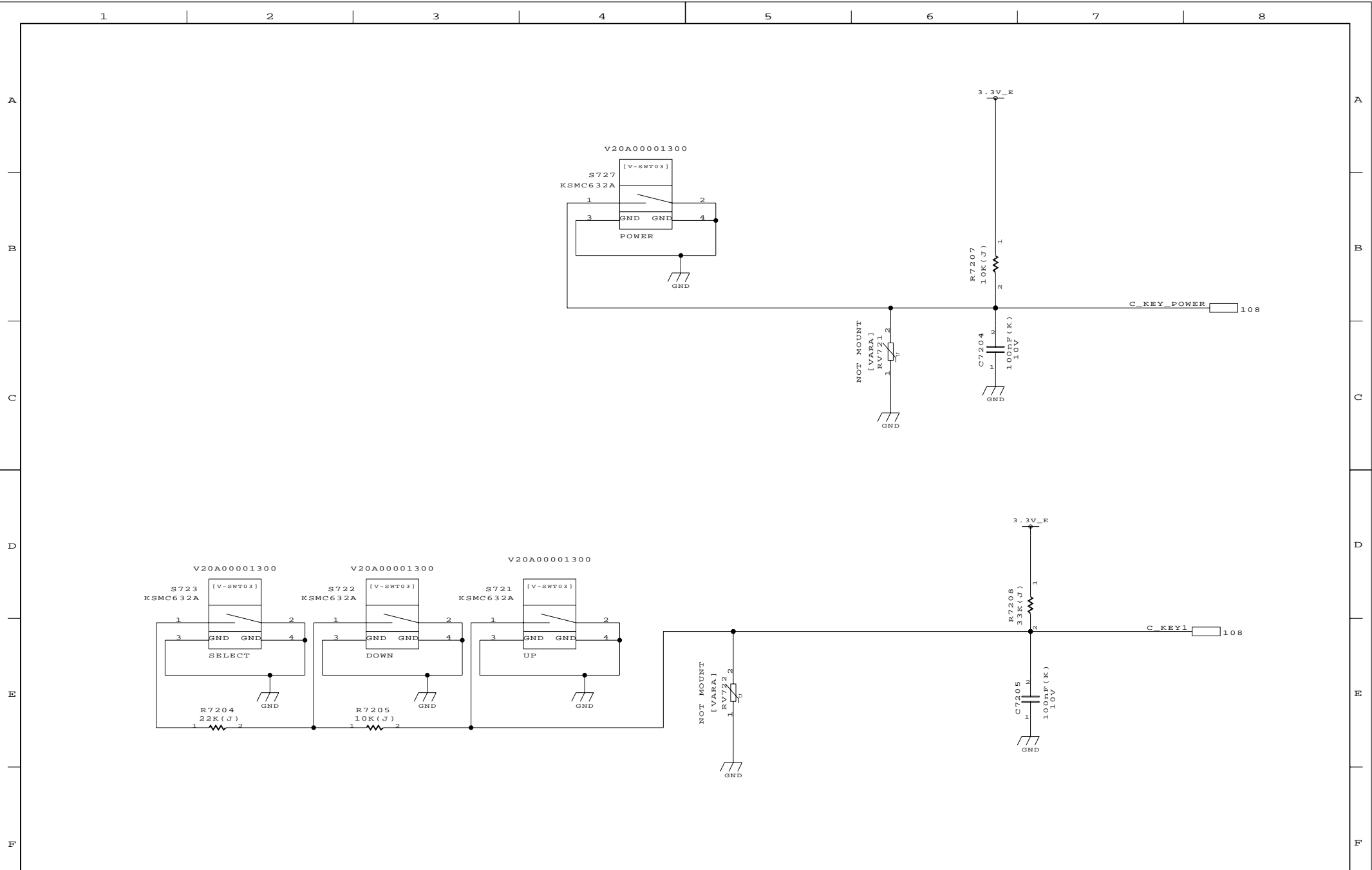

DESIGNED BY SASAKI	TITLE 24/29/32P1300	FUNCTION TACT KEY I/F	SH.NO. 702	PAGE NO. 28	REV.MARK MP DPL	DRAWING.NO. PE1129ZA
------------------------------	-------------------------------	---------------------------------	----------------------	-----------------------	---------------------------	--------------------------------

2013.03.06 17:06

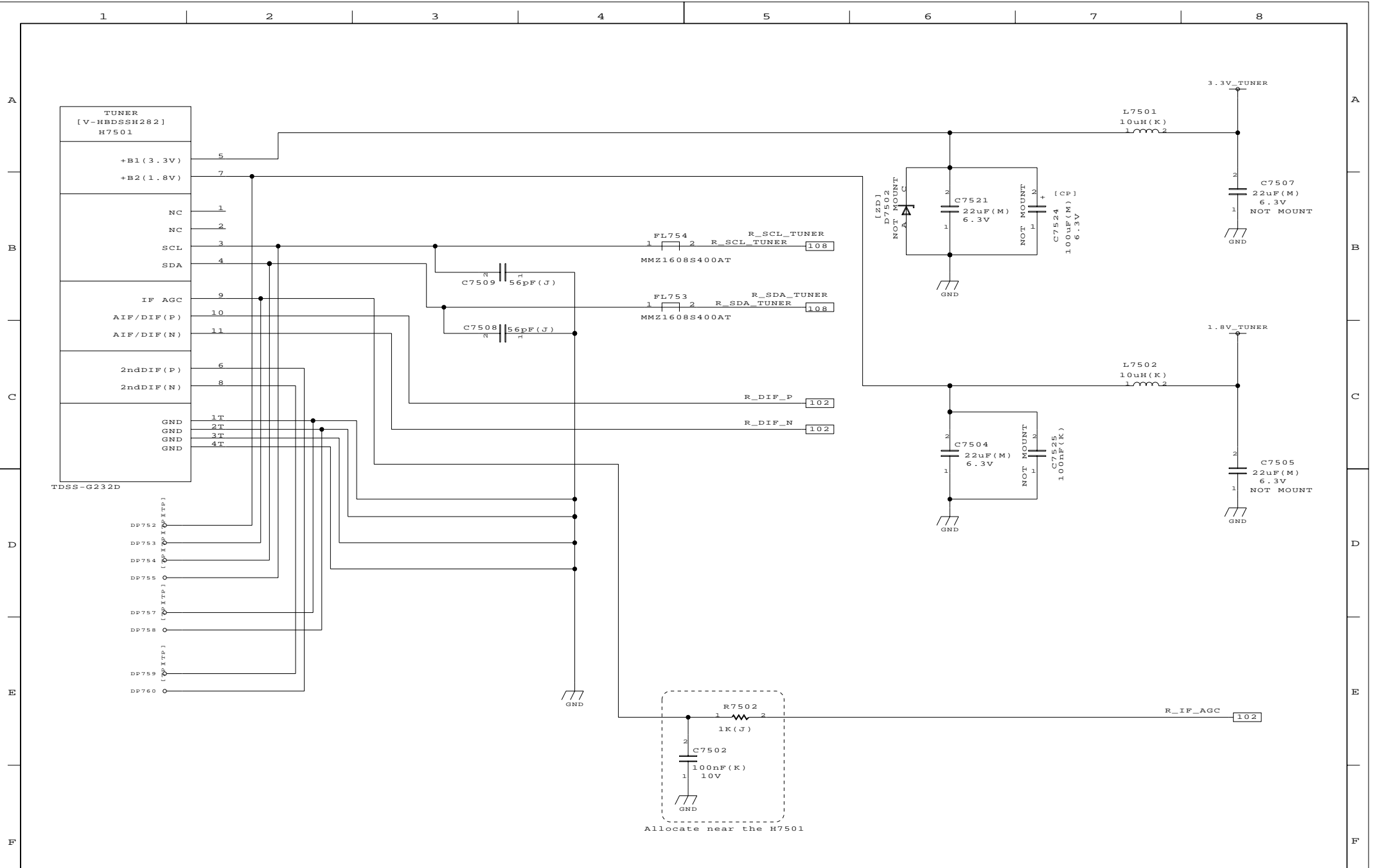

DESIGNED BY	TITLE	FUNCTION	SH.NO.	PAGE NO.	REV.MARK	DRAWING.NO.
KAWANABE	24/29/32P1300	Tuner	750	29	MP DPL	PE1129ZA

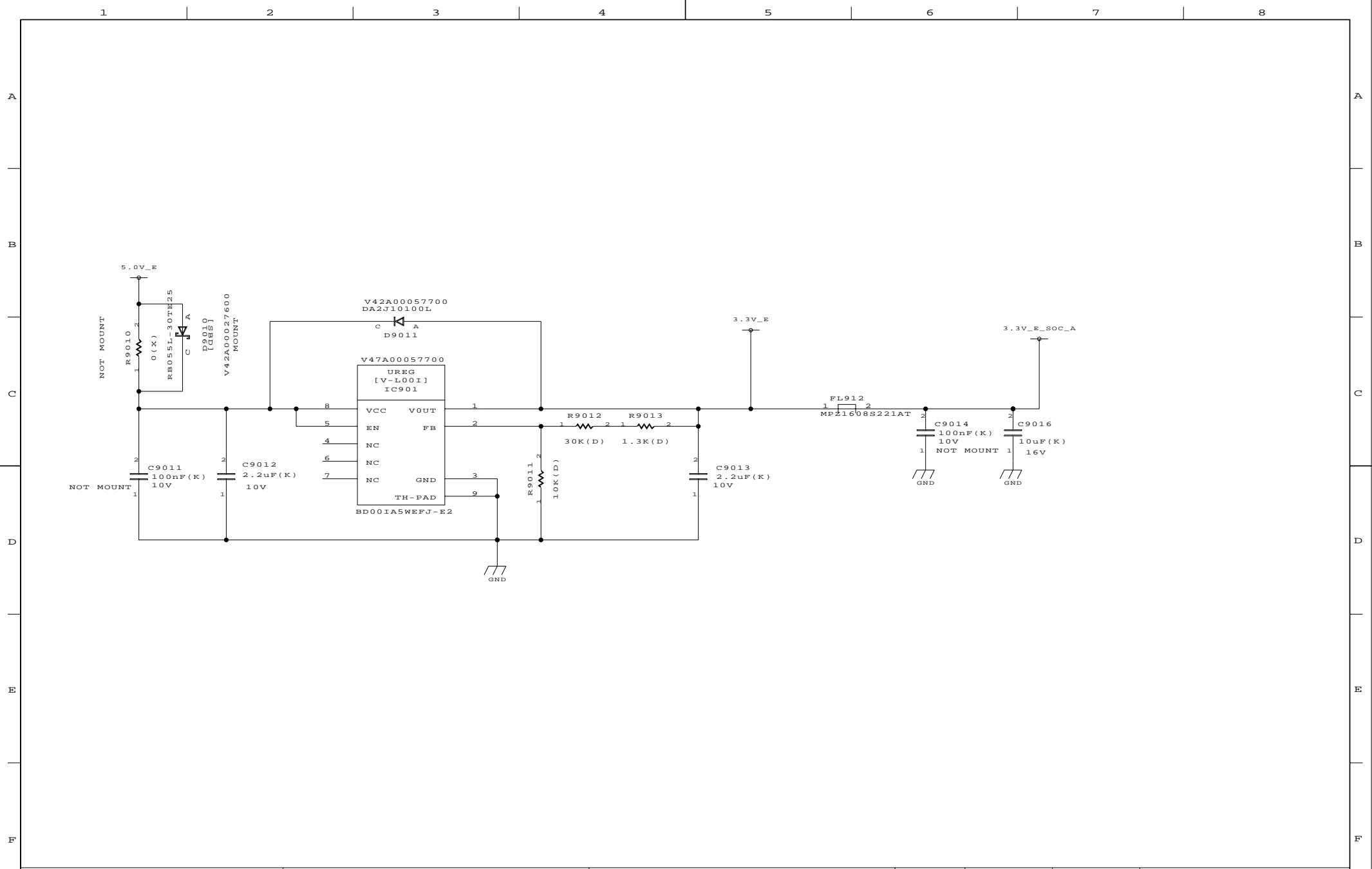

DESIGNED BY WATANABE	TITLE 24/29/32P1300	FUNCTION SoC 3.3V Power	SH.NO. 901	PAGE NO. 30	REV.MARK MP DPL	DRAWING.NO. PE1129ZA
--------------------------------	-------------------------------	-----------------------------------	----------------------	-----------------------	---------------------------	--------------------------------

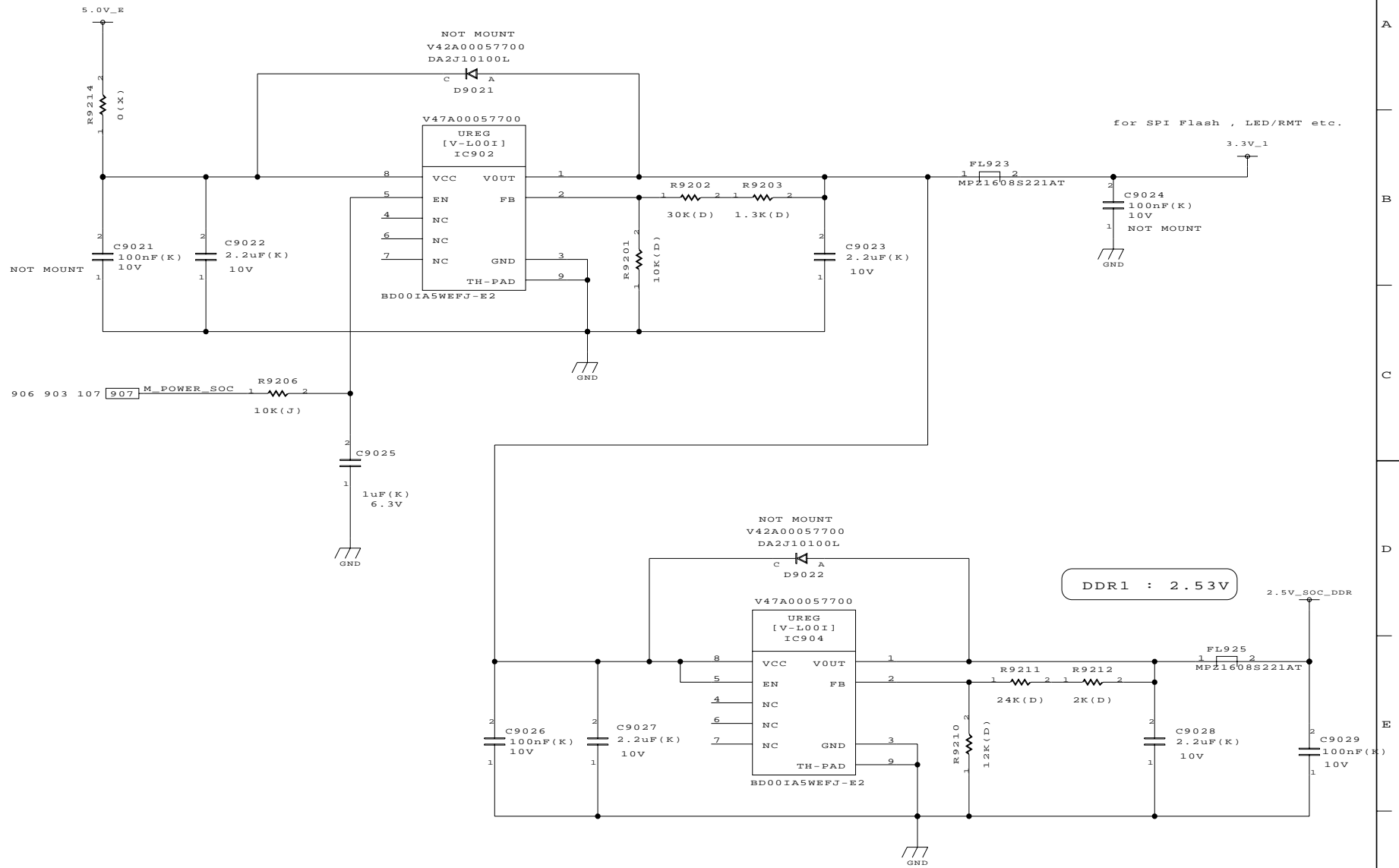

DESIGNED BY
WATANABE

TITLE
24/29/32P1300

FUNCTION
SoC DDR POWER

SH.NO.
902

PAGE NO.
31

REV.MARK
MP DPL

DRAWING.NO.
PE1129ZA

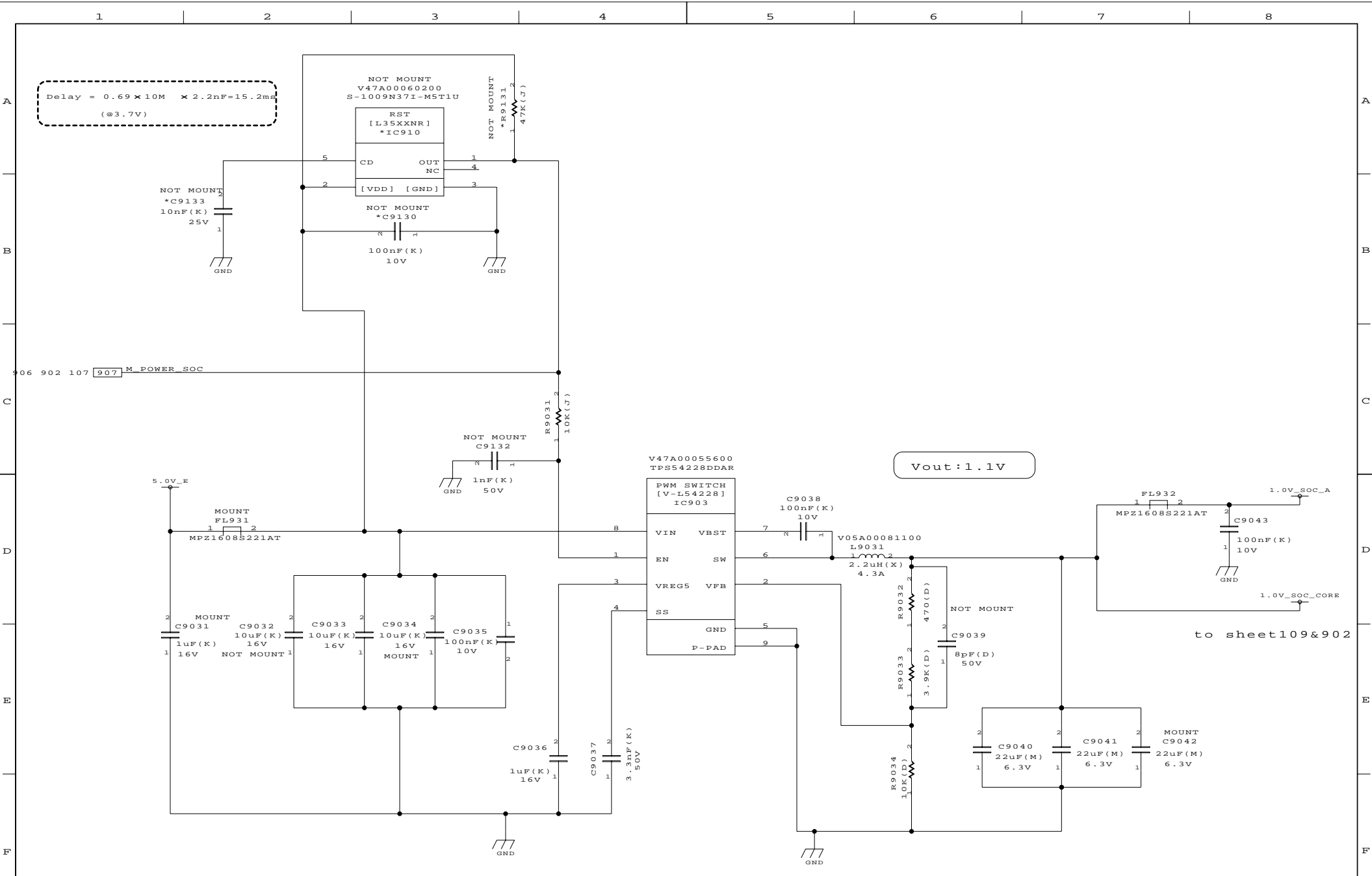

DESIGNED BY WATANABE	TITLE 24/29/32P1300	FUNCTION SoC 1.0V Power	SH.NO. 903	PAGE NO. 32	REV.MARK MP DPL	DRAWING.NO. PE1129ZA
-------------------------	------------------------	----------------------------	---------------	----------------	--------------------	-------------------------

2013.03.06 17:06

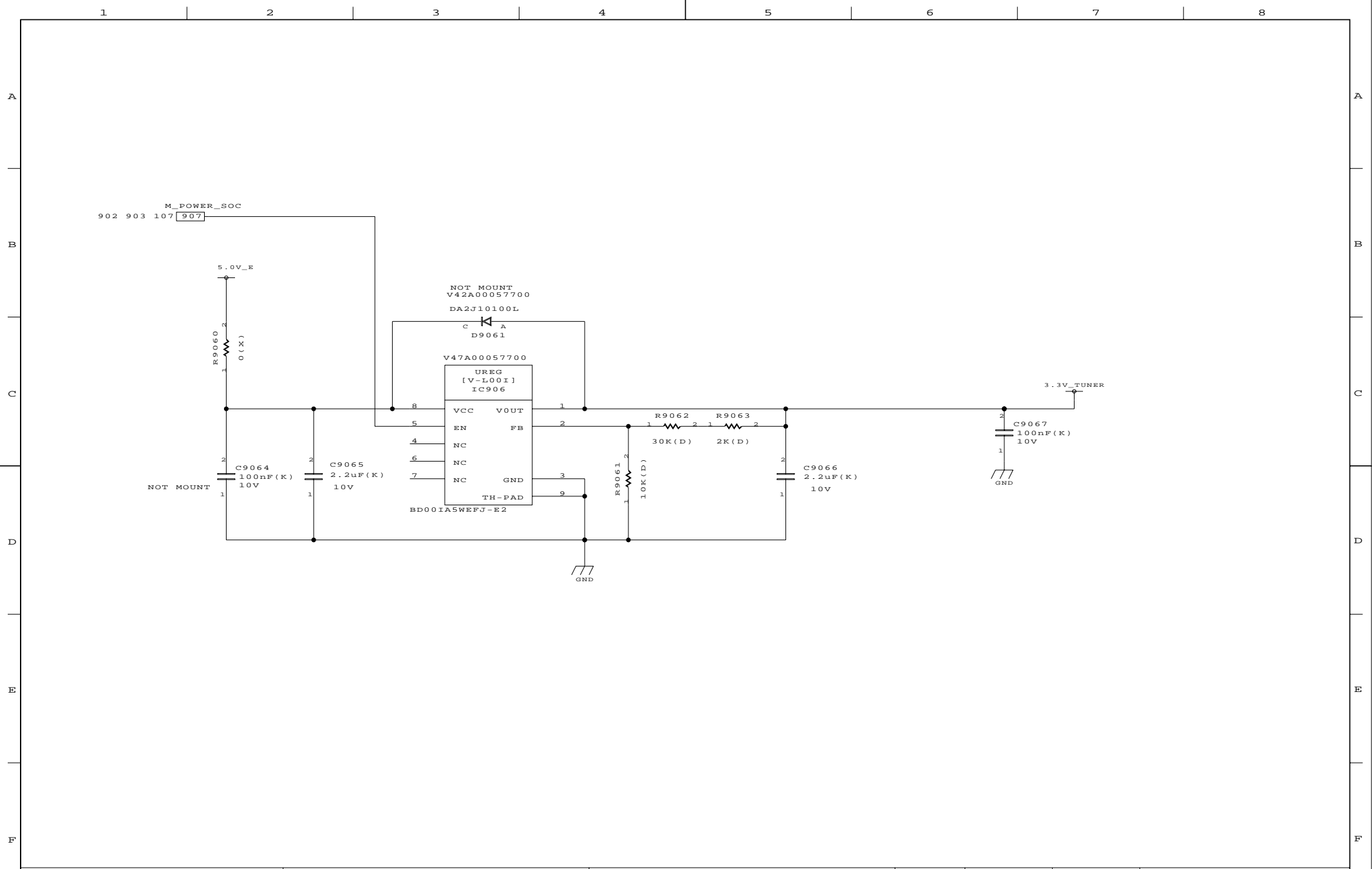

DESIGNED BY WATANABE	TITLE 24 / 29 / 32P1300	FUNCTION 3.3V2 Power	SH.NO. 906	PAGE NO. 34	REV.MARK MP DPL	DRAWING.NO. PE1129ZA
--------------------------------	-----------------------------------	--------------------------------	----------------------	-----------------------	---------------------------	--------------------------------

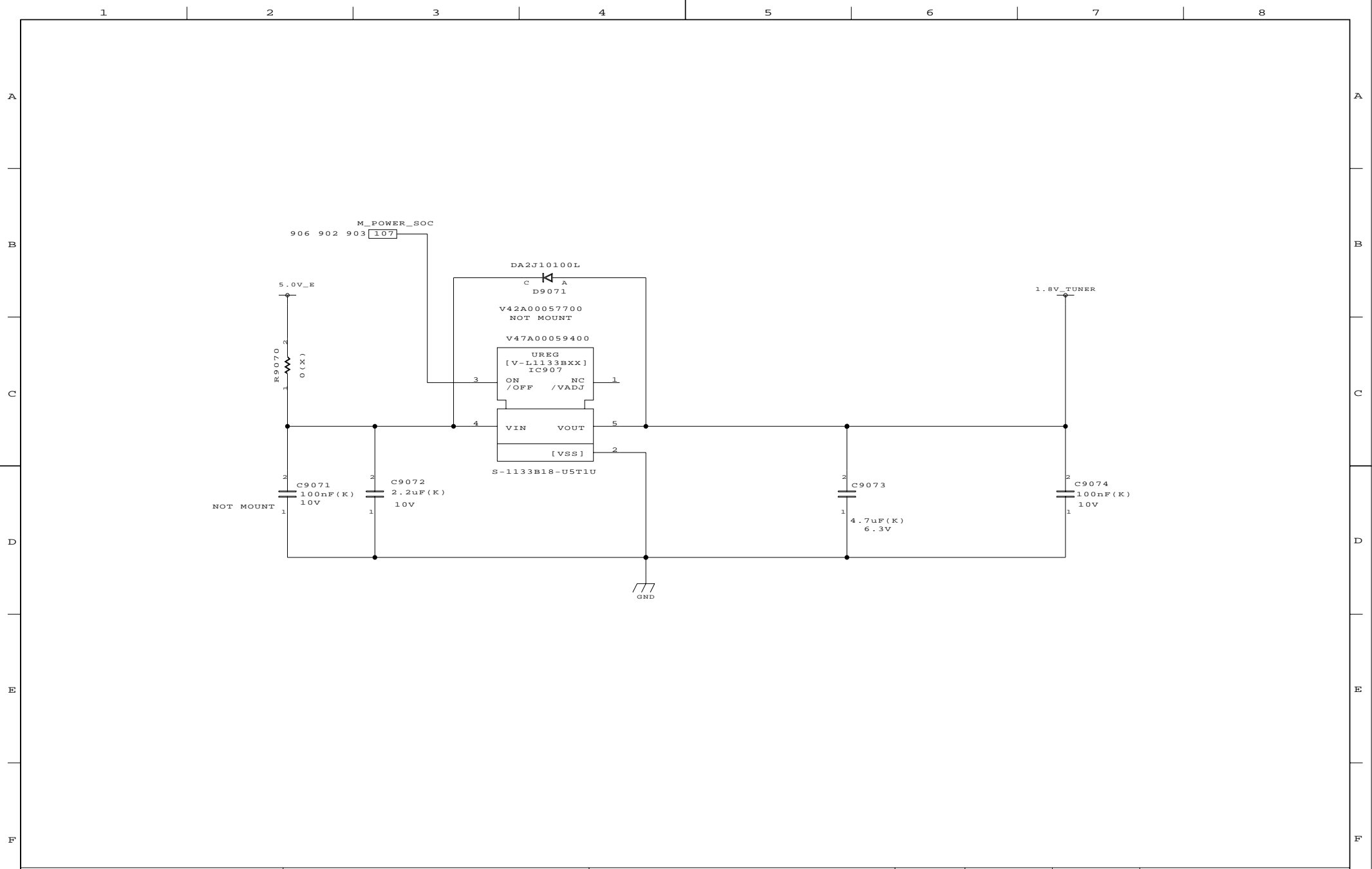

DESIGNED BY	TITLE	FUNCTION	SH.NO.	PAGE NO.	REV.MARK	DRAWING.NO.
WATANABE	24/29/32P1300	1.8V2 Power	907	35	MP DPL	PE1129ZA

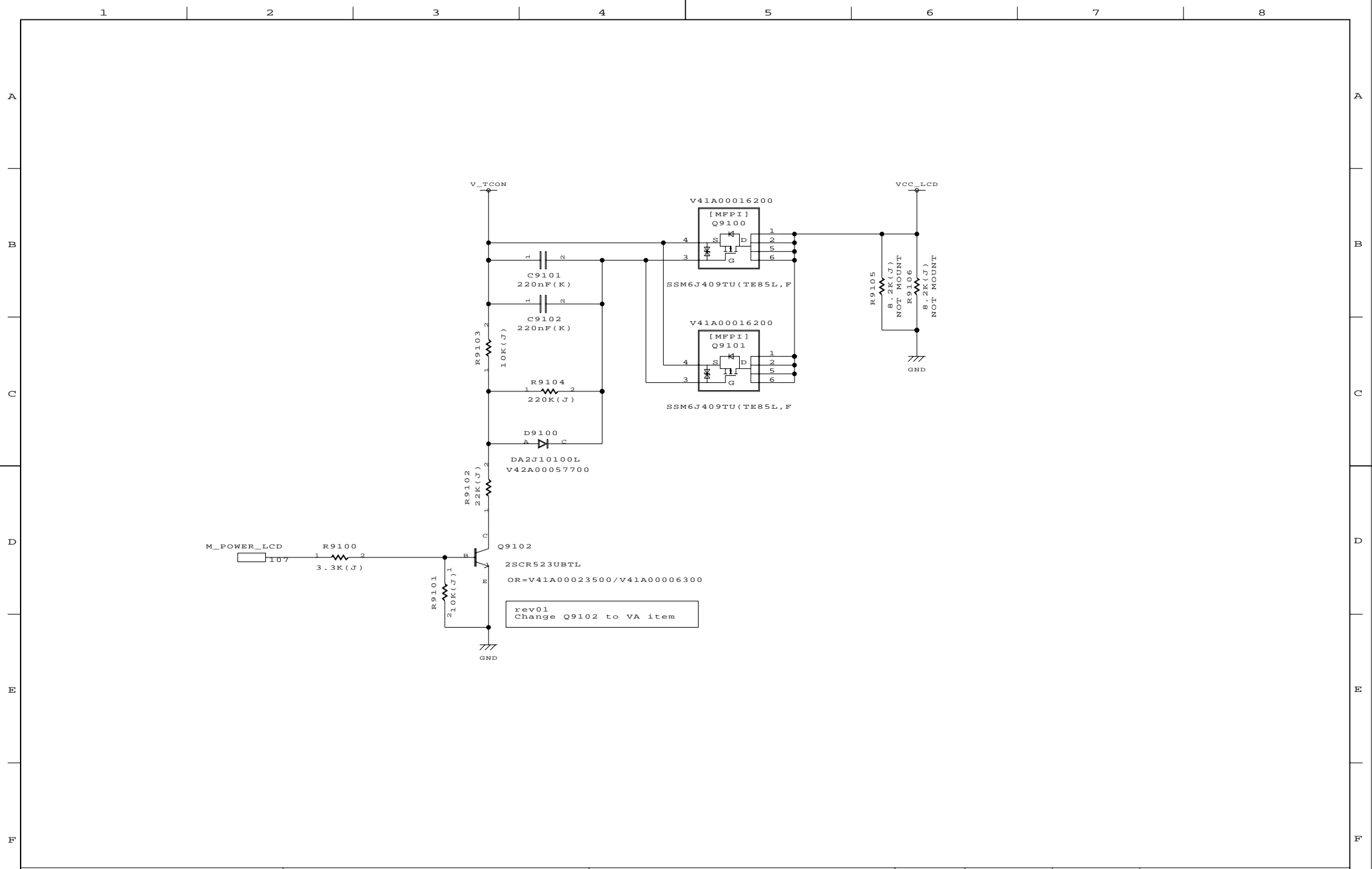

DESIGNED BY SASAKI	TITLE 24/29/32P1300	FUNCTION VCC LCD	SH.NO. 911	PAGE NO. 36	REV.MARK MP DPL	DRAWING.NO. PE1129ZA
------------------------------	-------------------------------	----------------------------	----------------------	-----------------------	---------------------------	--------------------------------

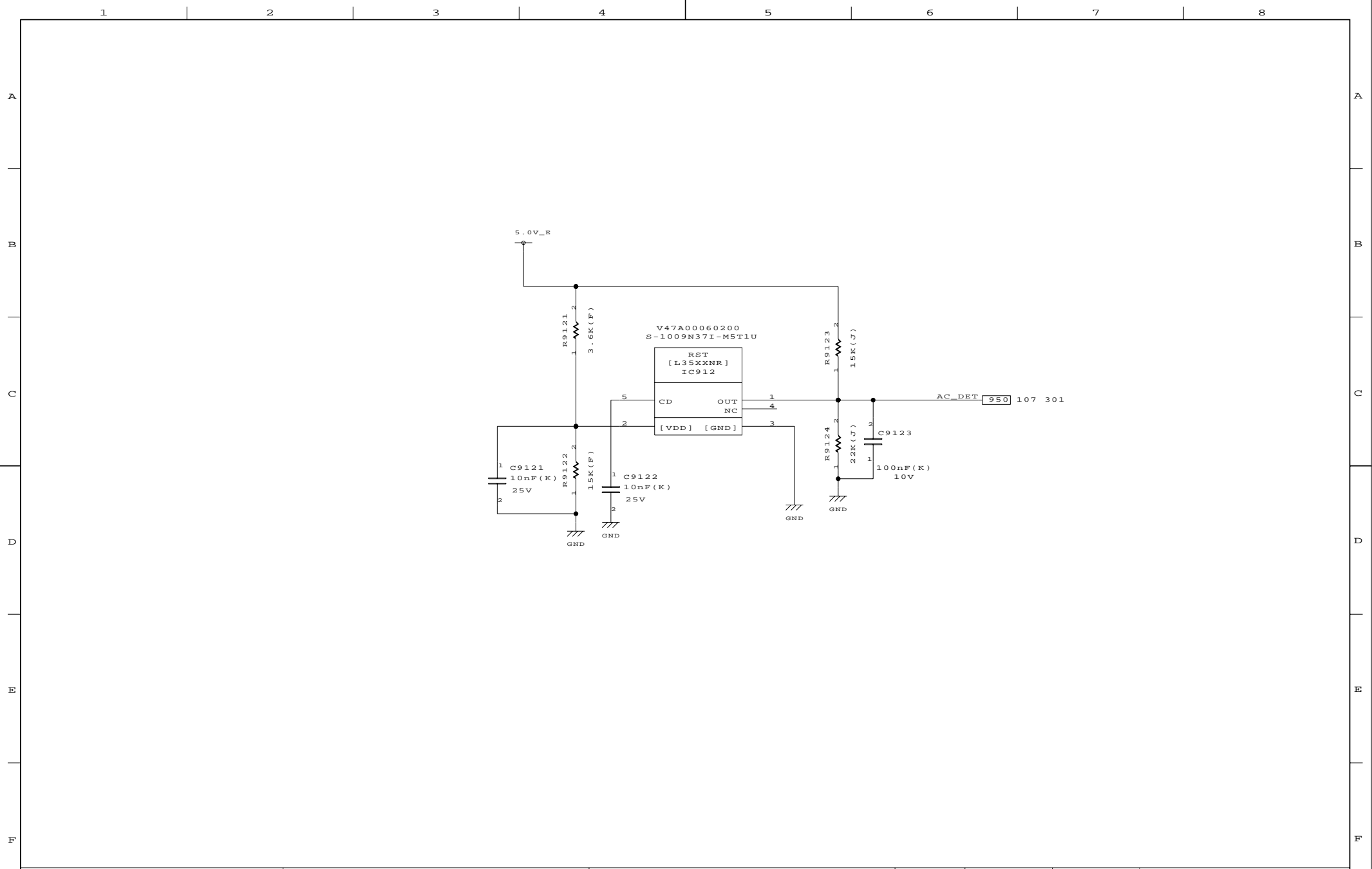

DESIGNED BY SASAKI	TITLE 24/29/32P1300	FUNCTION Power Control	SH.NO. 912	PAGE NO. 37	REV.MARK MP DPL	DRAWING.NO. PE1129ZA
------------------------------	-------------------------------	----------------------------------	----------------------	-----------------------	---------------------------	--------------------------------

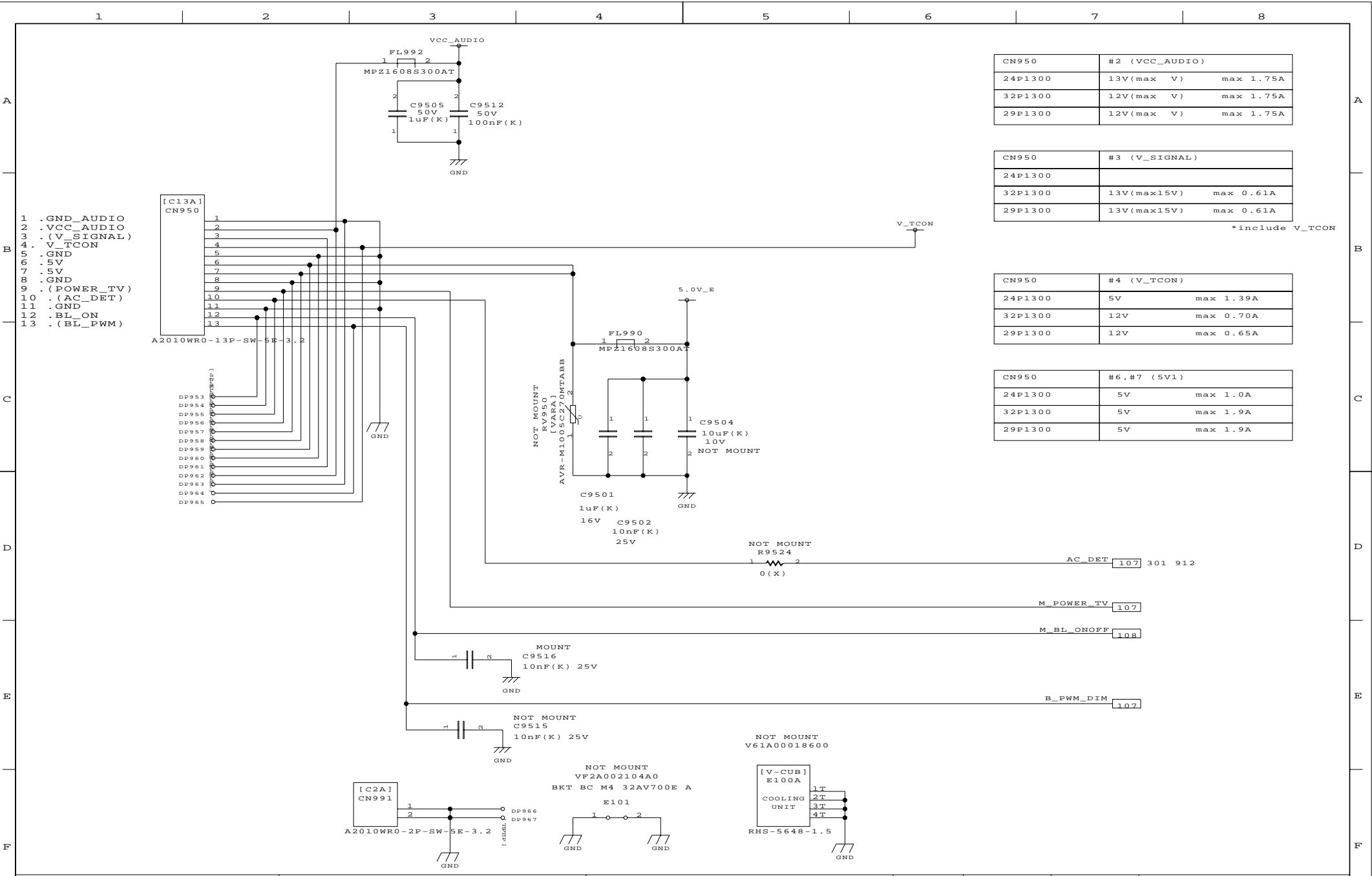

CN950	#2 (VCC_AUDIO)
24P1300	13V(max V) max 1.75A
32P1300	12V(max V) max 1.75A
29P1300	12V(max V) max 1.75A

CN950	#3 (V_SIGNAL)
24P1300	
32P1300	13V(max15V) max 0.61A
29P1300	13V(max15V) max 0.61A

*include V_TCON

CN950	#4 (V_TCON)
24P1300	5V max 1.39A
32P1300	12V max 0.70A
29P1300	12V max 0.65A

CN950	#6, #7 (5V1)
24P1300	5V max 1.0A
32P1300	5V max 1.9A
29P1300	5V max 1.9A

- 1 .GND_AUDIO
- 2 .VCC_AUDIO
- 3 .(V_SIGNAL)
- 4 .V_TCON
- 5 .GND
- 6 .5V
- 7 .5V
- 8 .GND
- 9 .(POWER_TV)
- 10 .(AC_DET)
- 11 .GND
- 12 .BL_ON
- 13 .(BL_PWM)

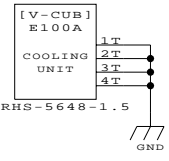
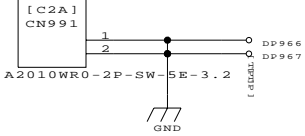
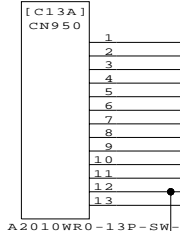

DESIGNED BY WATANABE/SASAKI	TITLE 24/29/32P1300	FUNCTION MAIN/POWER B-B	SH.NO. 950	PAGE NO. 38	REV.MARK MP DPL	DRAWING.NO. PE1129ZA
---------------------------------------	-------------------------------	-----------------------------------	----------------------	-----------------------	---------------------------	--------------------------------

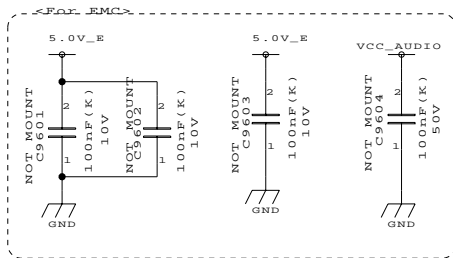

DESIGNED BY
Hattori

TITLE
24/29/32P1300

FUNCTION
EMC Control

SH.NO.
960

PAGE NO.
4/MP

REV.MARK
DPL

DRAWING.NO.
PE1129ZA

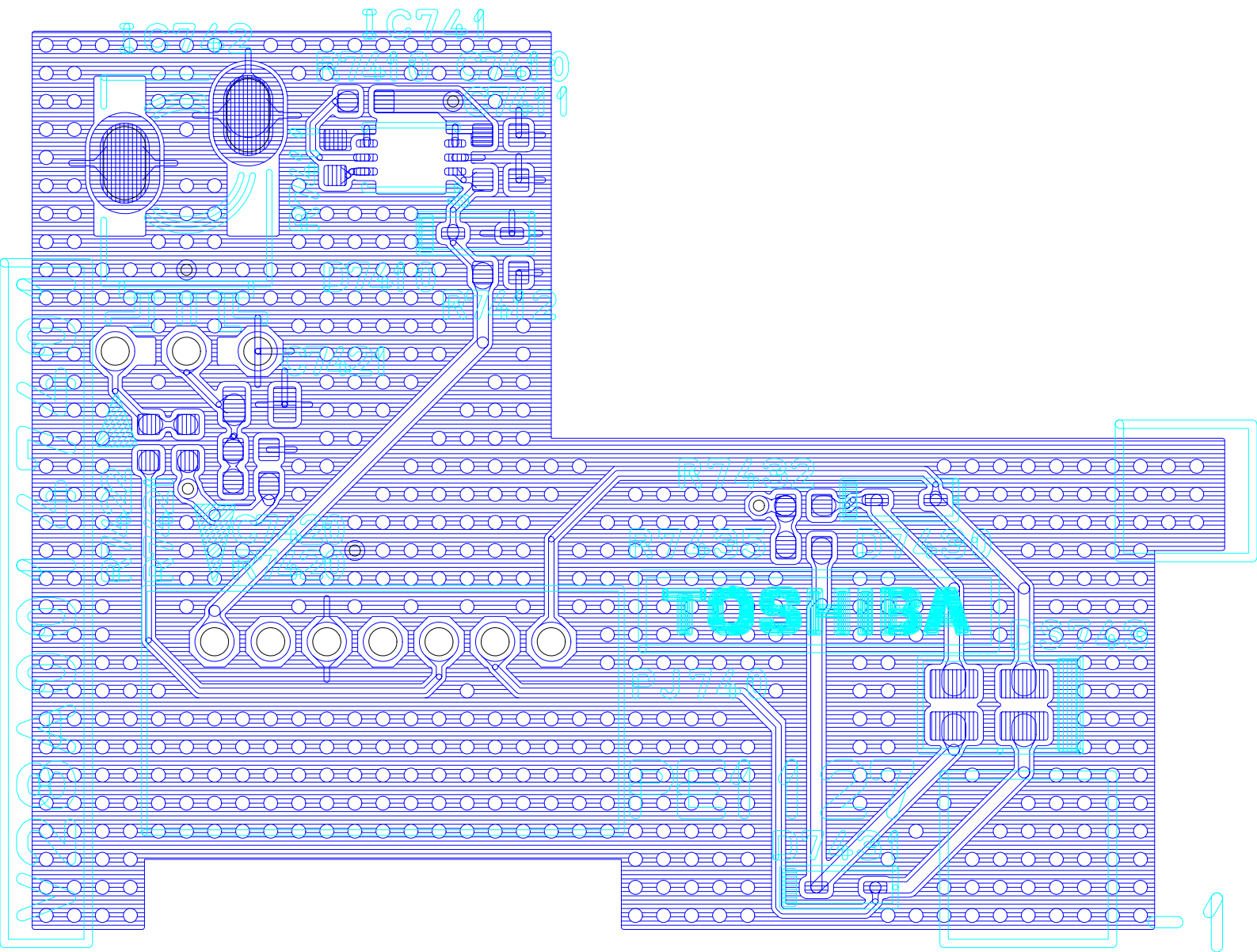

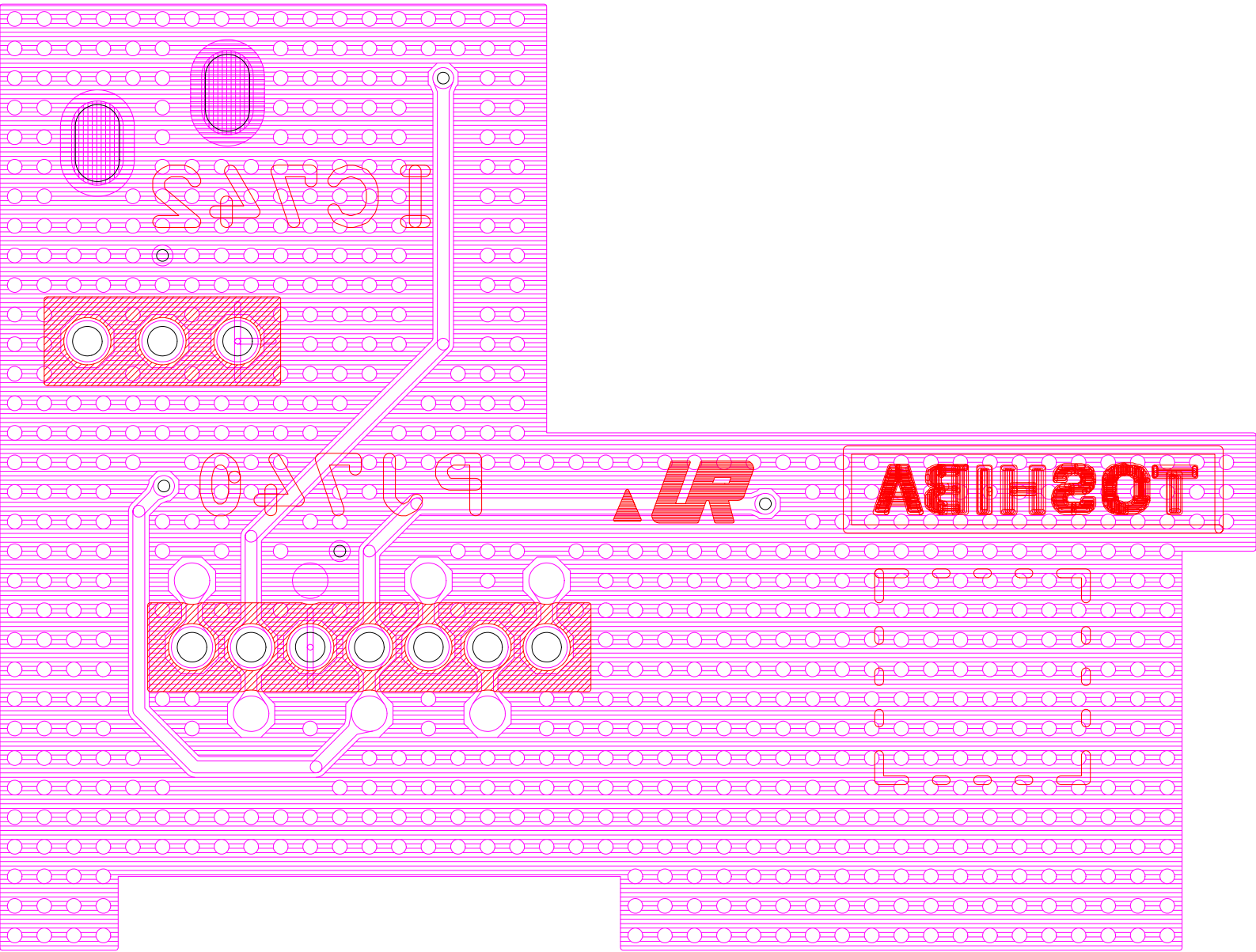

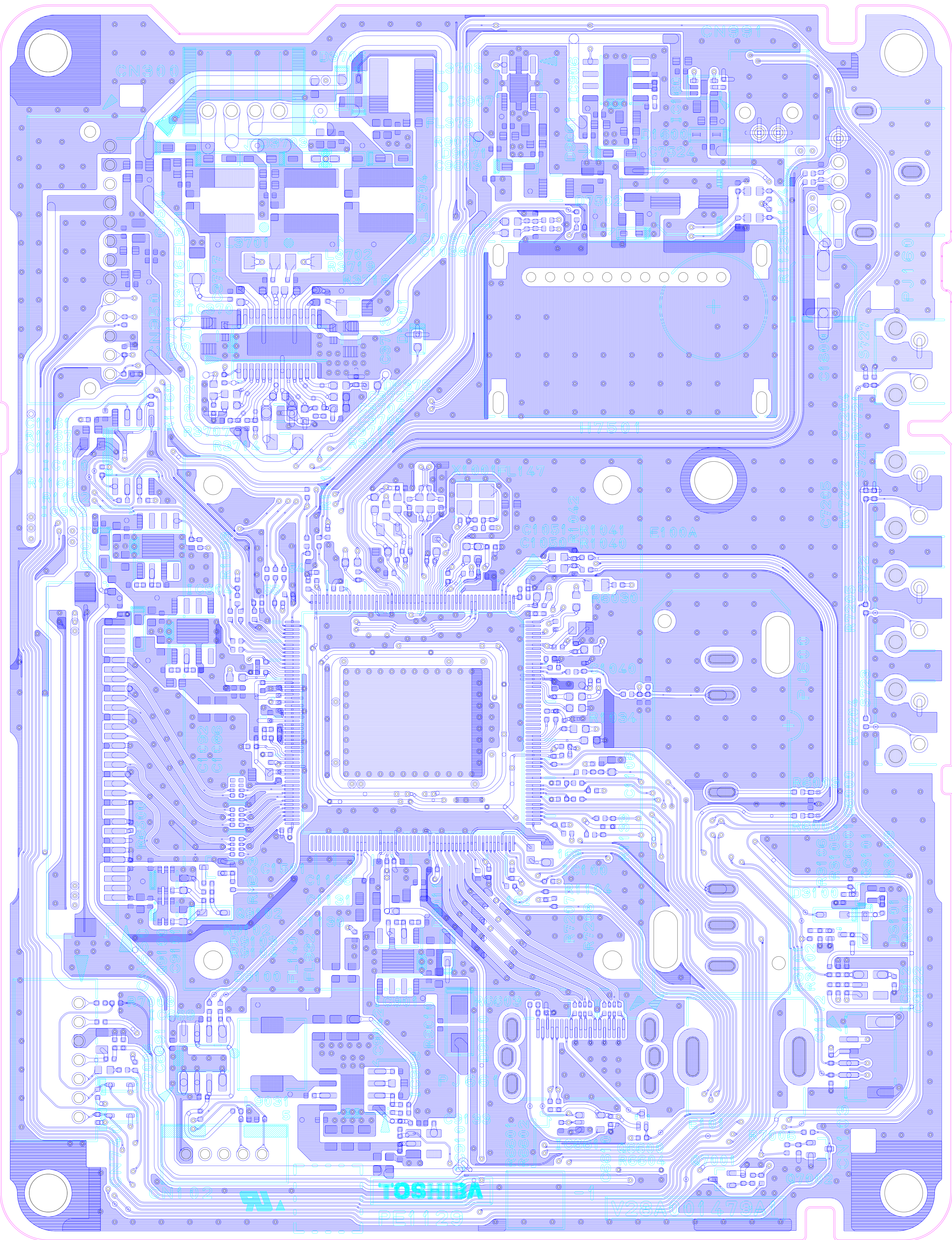

CN900

CN901

TOSHIBA

PE1129

V28A01479A

C200
C165
C166
C167
C168
C169
C170
C171
C172
C173
C174
C175
C176
C177
C178
C179
C180
C181
C182
C183
C184
C185
C186
C187
C188
C189
C190
C191
C192
C193
C194
C195
C196
C197
C198
C199

R3701
R3702
R3703
R3704
R3705
R3706
R3707
R3708
R3709
R3710
R3711
R3712
R3713
R3714
R3715
R3716
R3717
R3718
R3719
R3720
R3721
R3722
R3723
R3724
R3725
R3726
R3727
R3728
R3729
R3730
R3731
R3732
R3733
R3734
R3735
R3736
R3737
R3738
R3739
R3740
R3741
R3742
R3743
R3744
R3745
R3746
R3747
R3748
R3749
R3750
R3751
R3752
R3753
R3754
R3755
R3756
R3757
R3758
R3759
R3760

C1051
C1052
C1053
C1054
C1055
C1056
C1057
C1058
C1059
C1060
C1061
C1062
C1063
C1064
C1065
C1066
C1067
C1068
C1069
C1070
C1071
C1072
C1073
C1074
C1075
C1076
C1077
C1078
C1079
C1080
C1081
C1082
C1083
C1084
C1085
C1086
C1087
C1088
C1089
C1090
C1091
C1092
C1093
C1094
C1095
C1096
C1097
C1098
C1099
C1100

R6030
R6031
R6032
R6033
R6034
R6035
R6036
R6037
R6038
R6039
R6040
R6041
R6042
R6043
R6044
R6045
R6046
R6047
R6048
R6049
R6050
R6051
R6052
R6053
R6054
R6055
R6056
R6057
R6058
R6059
R6060
R6061
R6062
R6063
R6064
R6065
R6066
R6067
R6068
R6069
R6070
R6071
R6072
R6073
R6074
R6075
R6076
R6077
R6078
R6079
R6080

C7205
C7206
C7207
C7208
C7209
C7210
C7211
C7212
C7213
C7214
C7215
C7216
C7217
C7218
C7219
C7220
C7221
C7222
C7223
C7224
C7225
C7226
C7227
C7228
C7229
C7230
C7231
C7232
C7233
C7234
C7235
C7236
C7237
C7238
C7239
C7240
C7241
C7242
C7243
C7244
C7245
C7246
C7247
C7248
C7249
C7250

R6096
R6097
R6098
R6099
R6100
R6101
R6102
R6103
R6104
R6105
R6106
R6107
R6108
R6109
R6110
R6111
R6112
R6113
R6114
R6115
R6116
R6117
R6118
R6119
R6120
R6121
R6122
R6123
R6124
R6125
R6126
R6127
R6128
R6129
R6130
R6131
R6132
R6133
R6134
R6135
R6136
R6137
R6138
R6139
R6140

C7301
C7302
C7303
C7304
C7305
C7306
C7307
C7308
C7309
C7310
C7311
C7312
C7313
C7314
C7315
C7316
C7317
C7318
C7319
C7320
C7321
C7322
C7323
C7324
C7325
C7326
C7327
C7328
C7329
C7330
C7331
C7332
C7333
C7334
C7335
C7336
C7337
C7338
C7339
C7340

