

# SERVICE MANUAL

**MODEL : CI3352X/TSECX**  
**CHASSIS : P68SC & RM109**

## COLOUR TELEVISION RECEIVER

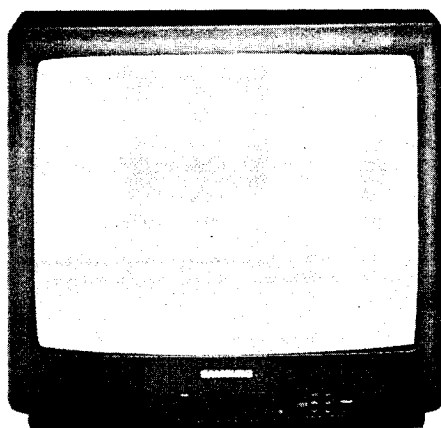

For Service Manuals Contact  
MAURITRON TECHNICAL SERVICES  
8 Cherry Tree Rd, Chinnor  
Oxon OX9 4QY  
Tel:- 01844-351694 Fax:- 01844-352554  
Email:- enquiries@mauritron.co.uk

### SPECIFICATIONS

Television System : PAL - I REMOTE CONTROL SYSTEM

Receiving Channel :

System	PAL - I
Band	
VHF	
UHF	21 - 69

Intermediate Frequency :

System	PAL - I
I-F Carrier Frequency	
Picture I-F Carrier	38.90
Sound I-F Carrier	33.40
Colour Sub Carrier	34.47

(Units:MHz)

Picture Tube :

14" LOCAL PURCHASE diagonal measured, Quick-start, In-line-gun, Black stripe, 90° degrees deflection

Power Requirements :

AC 240V, 50Hz, 77WATT

Antenna Input Impedance :

VHF,UHF : Telescopic dipole antenna (75 Ohm unbalanced type)

Speaker :

Impedance : 8 Ohm , 3W

Features :

Voltage synthesized tuning System, On-screen Display, Auto-fine Tuning, Dark Tube, Auto Brightness/Contrast Control, 29-Key Transmitter.

### SAFETY CAUTION :

Before servicing this model, it is important that a service technician refers to the "Safety Precaution" and "Product Safety Notice" described in the technical Service Manual.

- \* For continued X-radiation, replace the picture tube with original type.
- \* Design and specifications are subject to change without prior notice.
- \* WARNING-SHOCK HAZARDS - Use an isolation transformer when servicing.

### For Safe Use

1. Read all of these instructions.
2. Save these instructions for later use.
3. Unplug this television receiver from the wall outlet before cleaning. Do not use liquid cleaners or aerosol cleaning.

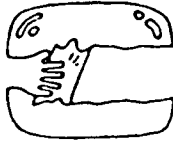

4. Do not use attachments not recommended by the television receiver manufacturer as they may cause hazards.
5. Do not use this television receiver near water for example, near a bathtub, washbowl, kitchen sink, or laundry tub, in a wet basement, or near a swimming pool, etc.
6. Do not place this television receiver on an unstable cart, stand, or table. The television receiver may fall, causing serious injury to a child or an adult, and serious damage to the appliance. Use only with a cart or stand recommended by the manufacturer, or sold with the television receiver. Wall or shelf mounting should follow the manufacturer's instructions, and should use a mounting kit approved by the manufacturer.
7. Slots and openings in the cabinet and the back or bottom are provided for ventilation, and to insure reliable operation of the television receiver and to protect it from overheating, these openings must not be blocked or covered. The openings should never be blocked by placing the television receiver should not be placed in a built-in installation such as a bookcase unless proper ventilation is provided.
8. This television receiver should be operated only from the type of power source indicated on the marking label. If you are not sure of the type of power supplied to your home, consult your television dealer or local power company. For television receivers designed to operated from battery power refer to the operating instructions.

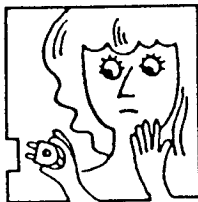

9. This television receiver is equipped with a polarized alternating-current line plug (a plug having one blade wider than the other.) This plug will fit the power outlet only one way. This is safety feature. If you are unable to insert the

plug fully into the outlet, try reversing the plug. If the plug should still fail to fit, contact your electrician to replace your obsolete outlet. Do not defeat the safety purpose on the polarized plug.

If your television receiver has a three-wire grounding-type plug, please note the following. This television receiver is equipped with a 3-wire grounding type plug (a plug having a third (grounding) pin). This plug will only fit into a grounding type power outlet. This is a safety feature. If you are unable to insert the plug into the outlet, contact your electrician to replace your obsolete outlet. Do not defeat the safety purpose of the grounding plug.



**FIGURE 1.**  
**EXAMPLE OF ANTENNA GROUNDING ACCORDING TO**  
**NATIONAL ELECTRICAL CODE INSTRUCTIONS**  
**CONTAINED IN ARTICLE 810 -**  
**"RADIO AND TELEVISION EQUIPMENT"**

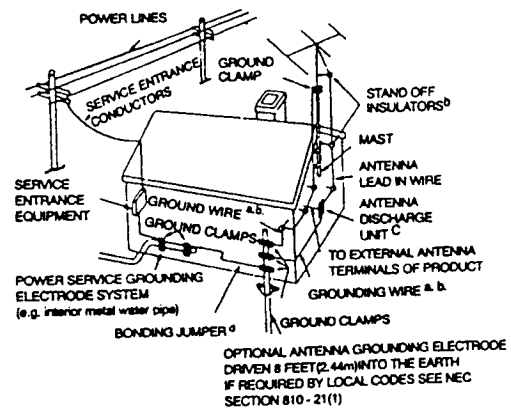

#### NOTES :

- a. Use No. 10 AWG (5.3mm<sup>2</sup>) copper, No. 8 AWG (8.4mm<sup>2</sup>) aluminum, No. 17 AWG (1.0mm<sup>2</sup>) copper clad steel or bronze wire, or larger, as a ground wire.
- b. Secure antenna lead-in and groundwires to house with stand-off insulators spaced from 4-6 feet (1.22-1.83m) apart.
- c. Mount antenna discharge unit as close as possible to where lead-in enters house.
- d. Use jumper wire not smaller than No. 6 AWG (13.3mm<sup>2</sup>) copper, or the equivalent, when a separate antenna grounding electrode is used.

10. Do not allow anything to rest on the power cord. Do not locate this television receiver where the cord will be abused by persons walking on it.



11. Follow all warnings and instructions marked on the television receiver.

12. If an outside antenna is connected to the television receiver, be sure the antenna system is grounded so as to provide some protection against voltage surges and built up static charges. Section 810 of the National Electrical Code, NFPA No. 70-1975, provides information with respect to proper grounding of the mast and supporting structure, grounding of the lead-in wire to an antenna discharge unit, size of grounding conductors, location of antenna discharge unit, connection to grounding electrodes, and requirements for the grounding electrode. See Figure 1.

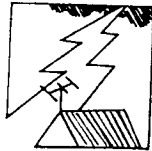

13. For added protection for this television receiver during a lightning storm, or when it is left unattended and unused to long periods of time, unplug it from the wall outlet and disconnect the antenna. This will prevent damage to the receiver due to lightning and power-line surges.

14. An outside antenna system should not be located in the vicinity of overhead power lines or other electric light or power circuits, or where it can fall into such power lines or circuits. When installing an outside antenna system extreme care should be taken to keep from touching, such power lines or circuits as contact with them might be fatal.

15. Do not overload wall outlets and extension cords as this can result in fire or electric shock.

16. Never push objects of any kind into this television receiver through cabinet slots as they may touch dangerous voltage points or short out parts that could result in a fire or electronic shock. Never spill liquid of any kind on the television receiver.

17. Do not attempt to service this television receiver yourself as opening or removing covers may expose you to dangerous voltage or other hazards. Refer all servicing to a qualified service personnel.

18. Unplug this television receiver from the wall outlet and refer servicing to a qualified service personnel under the following conditions.

a. When the power cord or plug is damaged or frayed.

b. If liquid has been spilled into the television receiver.

c. If the television receiver has been exposed to rain or water.

d. If the television receiver does not operate normally by following the operating instructions. Adjust only those controls that are covered by the operating instruction as improper adjustment of their controls may result in damage and will often require extensive work by a qualified technician to restore the television receiver to a normal operation.

e. If the television receiver has been dropped or the cabinet has been damaged.

f. When the television receiver exhibits a distinct change in performance-this indicates a need for service.

19. When replacement parts are required, be sure the service technician has used replacement parts specified by the manufacturer that have the same characteristics as the original part. Unauthorized substitutions may result in fire, electric shock, or other hazards.

20. Upon completion of any service or repairs to this television receiver, ask the service technician to perform routine safety checks to determine that the television is in safe operating condition.

21. Television equipment and cart combination should be moved with care. Quick stops, excessive force, and uneven surfaces may cause the equipment and cart combination to overturn.



For Service Manuals Contact  
MAURITRON TECHNICAL SERVICES  
8 Cherry Tree Rd, Chinnor  
Oxon OX9 4QY  
Tel:- 01844-351694 Fax:- 01844-352554  
Email:- enquiries@mauritron.co.uk



## PRODUCT SAFETY NOTICE

Many electrical and mechanical parts in this chassis have special safety-related characteristics. These characteristics are often passed unnoticed by visual inspection and the protection afforded by them cannot necessarily be obtained by using replacement components rated for higher voltage, wattage, etc. The replacement parts which have these special safety characteristics are identified in this manual and its

supplements: electrical components having such features are identified by shading on the schematic diagram and the parts list. Before replacing any of these components, read the parts list in this manual carefully. The use of substitute parts which do not have the same safety characteristics in the parts list may create a shock, fire, X-radiation or other hazards.

## SERVICE NOTES

1. when replacing the parts or the circuit boards, clamp the lead wires to the terminals before soldering.
2. When replacing a high wattage resistor (oxide metal film resistor) in the circuit board, keep the resistor 10mm (1/2 in) away from the circuit board.
3. Keep the wires away from high voltage or high temperature components.
4. If any fuse in this TV receiver is blown, replace it with the FUSE specified in the chassis parts list.

 <p>The lightning flash and arrowhead within the triangle is a warning sign alerting you of "dangerous voltage" inside the product.</p>	<div style="border: 1px solid black; padding: 5px; margin-bottom: 5px;"> <p style="text-align: center; background-color: #cccccc; margin: 0;"><b>CAUTION</b></p> <p style="text-align: center; margin: 0;"><b>RISK OF ELECTRIC SHOCK</b></p> <p style="text-align: center; margin: 0;"><b>DO NOT OPEN</b></p> </div> <p>CAUTION : To reduce the risk of electric shock, do not remove cover (or back) no user serviceable parts inside. Refer servicing to qualified service personnel.</p>	 <p>The exclamation point within the triangle is a warning sign alerting you of important instructions accompanying the product.</p>
---	---	--

\* IN CASE OF  
 3312 SERIES  
 3313 SERIES  
 3315 SERIES  
 3325 SERIES  
 3327 SERIES  
 5012 SERIES  
 5013 SERIES  
 5015 SERIES  
 5025 SERIES  
 5026 SERIES  
 5027 SERIES  
 5322 SERIES  
 3351 SERIES

PULL THE CHASSIS-RAIL  
 TO BESIDE ( ① ) THEN  
 SEPARATE THE CHASSIS  
 ( ② )

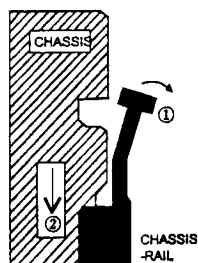

\* IN CASE OF  
 3351 SERIES  
 3352 SERIES  
 3357 SERIES  
 3852 SERIES  
 3857 SERIES  
 5051 SERIES  
 5052 SERIES  
 5057 SERIES

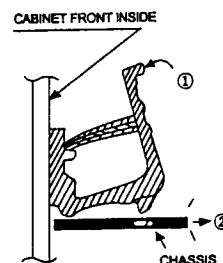

AT FIRST PUSH THE LOCK SWITCH, (①) THEN  
 TAKE OUT THE CHASSIS. (②)  
 CODE NO : 38114-899-710

## X-RADIATION PRECAUTION

1. The excessive high voltage can produce potentially hazardous X-RADIATION. To avoid such hazards, the high voltage must not exceed the specified limit. The nominal value of the high voltage of this receiver is 24.0KV at zero beam current (minimum brightness). The high voltage must not, under any circumstances, exceed 30KV. Each time a receiver requires servicing and the high voltage should be checked following the HIGH VOLTAGE CHECK procedure in this manual. It is recommended that the reading of the high voltage should be recorded as a part of the service record.

It is important to use an accurate and reliable high voltage meter.

2. The only source of X-RADIATION is this TV receiver. It is the picture tube. For continued X-RADIATION protection, the replacement tube must be exactly the same type as specified in the parts list.
3. Some parts in this receiver have special safety related characteristics for X-RADIATION protection. For continued safety, the parts replacement should be undertaken only after referring to the PRODUCT SAFETY NOTICE.

## SAFETY PRECAUTION

**Warning :** The service should not be attempted by anyone unfamiliar with the necessary precautions in this receiver. The followings are the necessary precautions to be observed before servicing.

Since the chassis of this receiver is directly connected to the AC power line-(Hot chassis), an isolation transformer should be used during any dynamic service to avoid possible shock hazards.

1. Always discharge the picture tube anode to the CRT conductive coating before handling the picture tube. The picture tube is highly evacuated and if broken, the glass fragments will be violently expelled. Use shatterproof goggles and keep the picture tube away from the bare body during a handling.
2. When replacing a chassis in the cabinet, it is always certain that all the protective devices are put back in place, such as non-metallic control knobs, insulating covers, shields, isolation resistor-capacitor network, etc.

3. Before returning the set to the customer, always perform an AC leakage current check on the exposed metallic parts of the cabinet, such as antennas, terminal, screwheads, metal overlays, control shafts, etc. To be sure the set is safe to operate without danger of electrical shock. Plug the AC line cord directly to the AC outlet (do not use a line isolation transformer during this check). Use an AC voltmeter having 5000 ohm per volt or more sensitivity in the following manner. Connect a 1500 ohm 10 watt resistor, paralleled by a 0.15  $\mu$  F, AC type capacitor, between a good earth ground (water pipe, conduit etc.) and the exposed metallic parts, one at a time. Measure the AC voltage across the combination of 1500 ohm resistor and 0.15  $\mu$  F capacitor. Reverse the AC plug at the AC outlet and repeat the AC voltage measurements for each exposed metallic part. The measured voltage must not exceed 0.3volts RMS. This corresponds to 0.2 milliamp AC. Any value exceeding this limit constitutes a potential shock hazard and must be corrected immediately.

For Service Manuals Contact  
**MAURITRON TECHNICAL SERVICES**  
8 Cherry Tree Rd, Chinnor  
Oxon OX9 4QY  
Tel:- 01844-351694 Fax:- 01844-352554  
Email:- enquiries@mauritron.co.uk

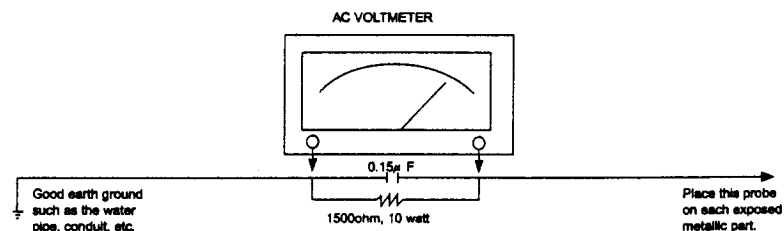

Figure 1.AC Leakage Current Check

# TABLE OF CONTENTS

<p><b>1.INSTRUCTIONS</b> ..... 1</p> <p><b>2.CHASSIS BLOCK DIAGRAM</b> ..... 2</p> <p><b>3.POWER SUPPLY SECTION</b></p> <p>    1.BLOCK-DIAGRAM ..... 3</p> <p>    2.INTRODUCTION ..... 3 - 4</p> <p>    3.IC SPECIFICATION (SDH209B)</p> <p>        1)Block-Diagram ..... 4</p> <p>        2)Electrical Characteristics ..... 4</p> <p><b>4.CHROMA, VIDEO, IF, SOUND, DEFLECTION SECTION</b></p> <p>    1.IC SPECIFICATION(TDA8362)</p> <p>        1)Introduction ..... 5</p> <p>        2)Block-Diagram ..... 5</p> <p>        3)Pin Function ..... 6</p> <p>    2.CHROMA VIDEO SECTION</p> <p>        1)Block-Diagram ..... 6</p> <p>        2)Actuating Description ..... 6</p> <p>        3)IC Block-Diagram (TDA 8362)..... 7</p> <p>        4)IC Specification (TDA 8395) ..... 7- 8</p> <p>        5)IC Specification (TDA4661) ..... 8- 9</p> <p>    3.IF SECTION</p> <p>        1)Block-Diagram ..... 9</p> <p>        2)Actuating Description ..... 9 - 10</p> <p>        3)IC Block-Diagram (TDA 8362) ..... 10</p> <p><b>4.SOUND SECTION</b></p> <p>    1)Block-Diagram ..... 10</p> <p>    2)Actuating Description ..... 10 - 11</p> <p>    3)IC Block-Diagram (TDA8362)..... 11</p> <p>    4)IC Specification (TDA1013A) ..... 11</p> <p><b>5.DEFLECTION SECTION</b></p> <p>    1)Block-Diagram ..... 12</p>	<p>        2)Actuating Description ..... 12</p> <p>        3)IC Block-Diagram (TDA8362) ..... 13</p> <p>        4)IC Specification (KA2131) ..... 13</p> <p><b>5.REMOCON SECTION</b></p> <p>    1.INTRODUCTION ..... 14</p> <p>    2.BLOCK-DIAGRAM ..... 15</p> <p>    3.PIN FUNCTION ..... 15 - 16</p> <p><b>6.ALIGNMENT and ADJUSTMENT</b></p> <p>    1.GENERAL INFORMATIONS ..... 16</p> <p>    2.AUTOMATIC DEGAUSSING ..... 16</p> <p>    3.HIGH VOLTAGE CHECK ..... 16</p> <p>    4.HORIZONTAL PHASE ADJUSTMENT ..... 16</p> <p>    5.VERTICAL HEIGHT ADJUSTMENT ..... 17</p> <p>    6.SCREEN ADJUSTMENT ..... 17</p> <p>    7.FOCUS ADJUSTMENT ..... 17</p> <p>    8.R-F AGC ADJUSTMENT ..... 17</p> <p>    9. COLOUR PURITY ADJUSTMENT ..... 17</p> <p>    10.CRT WHITE BALANCE ADJUSTMENTS ..... 17</p> <p>    11.CONVERGENCE ADJUSTMENTS</p> <p>        1)Centre Convergence Adjustment ..... 17 - 19</p> <p>        2)Circumference Convergence Adjustment ..... 19</p> <p>    12.VIF(SIF) ADJUSTMENT ..... 19</p> <p><b>7.TELETEXT SECTION(OPTION)</b></p> <p>    1.TTX BLOCK DIAGRAM ..... 20</p> <p>    2.SEMICONDUCTOR SPECIFICATION ..... 20 - 26</p> <p><b>8.TROUBLESHOOTING CHARTS</b> ..... 27 - 30</p> <p><b>9.INSERTING FROM OF THE IMPORTANT PARTS</b> ..... 31</p> <p><b>10.CHASSIS REPLACEMENT PARTS LIST</b> ..... 32 - 37</p> <p><b>11.EXPLODEO-VIEW &amp; PARTS LIST</b> ..... 38 - 39</p> <p><b>12.SCHEMATIC-DIAGRAM</b> ..... 41 - 42</p> <p><b>13.PWB PATTERN &amp; LOCATION</b> ..... 43</p>
--	--

MEMO

.....

.....

.....

MEMO

.....

.....

.....

# 1. INSTRUCTIONS

## 1. IC LINE UP

Loc No	Specification	Description	Remarks
IC101	TDA8362	PAL/NTSC/SECAM Decoder (VIF/SIF/VIDEO, Chroma/Deflection)	
IC502	TDA8395	SECAM Decoder	
IC501	TDA4661	1 H Delay	
IC301	KA2131	Vertical output	
RIC01	SPM-109	8bit $\mu$ — com	
RIC02	X24C02P	NON-VOLTAGE Memory	
IC102	LA7910	BAND Docoder	
IC602	TDA1013A	Sound output Amplifier	
IC801	SDH209B	PWM-Controller for SMPS	
XIC01	SAA3010	Remote Control	

## 2. MEANS OF COMPONENTS NUMBER SERIES

100 Series -----	TUNER/IF/AFT/AGC processing	500 Series -----	Chroma/peaking processing
200 Series -----	Video/Luminance processing	600 Series -----	Sound processing
300 Series -----	Vertical deflection	700 Series -----	Video/Chroma switchingSection
400 Series -----	Horizontal deflection	800 Series -----	AC input, power supply circuits
		900 Series -----	CRT Driver Section

## 3. ABBREVIATION

ABCL : Automatic Brightness Contrast Limiting	LLD : Low Level Detector
ABL : Automatic Beam Limiting	LPF : Low Pass Filter
AC : Alternating Current	MTS : Multi Television Sound
ACC : Automatic Color Control	NFB : Negative Feed Back
AFC : Automatic Frequency Control	NTSC : National Television System Committee System
AFT : Automatic Fine tuning	NVRAM : Non-Volatile Random Access Memory
AGC : Automatic Gain Control	PAL : Phase Alternating by Line System
AM : Amplitude Modulation	PCM : Pulse Coded Modulation
APC : Automatic Phase Control	PIF : Picture Intermediate Frequency
APL : Average Picture Level	PLL : Pulse Locked Loop
AVC : Automatic Volume Control	PWM : Pulse Width Modulation
DB : Decibel	RAM : Random Access Memory
DC : Direct Current	RF : Radio Frequency
DIP : Dual-in-line Package	SAW : Surface Acoustic Wave
DY : Deflection York	SIF : Sound Intermediated Frequency
D/A : Digital to Analog	S/N : Signal Noise
F.B : Fast Blanking	I <sup>2</sup> C : Inter Integrated Circuit
FBT : Flyback Trans	DAC : Digital Analog Converter
FM : Frequency Modulation	BPF : Band Pass Filter
HDT : Horizontal Drive Trans	OSD : On-Screen Display
IC : Integrated Circuit	SCL : Serial Clock Line
IF : Intermediate Frequency Trans	SDA : Serial Data Line
IFT : intermediate Frequency Trans	

## 2.CHASSIS BLOCK DIAGRAM

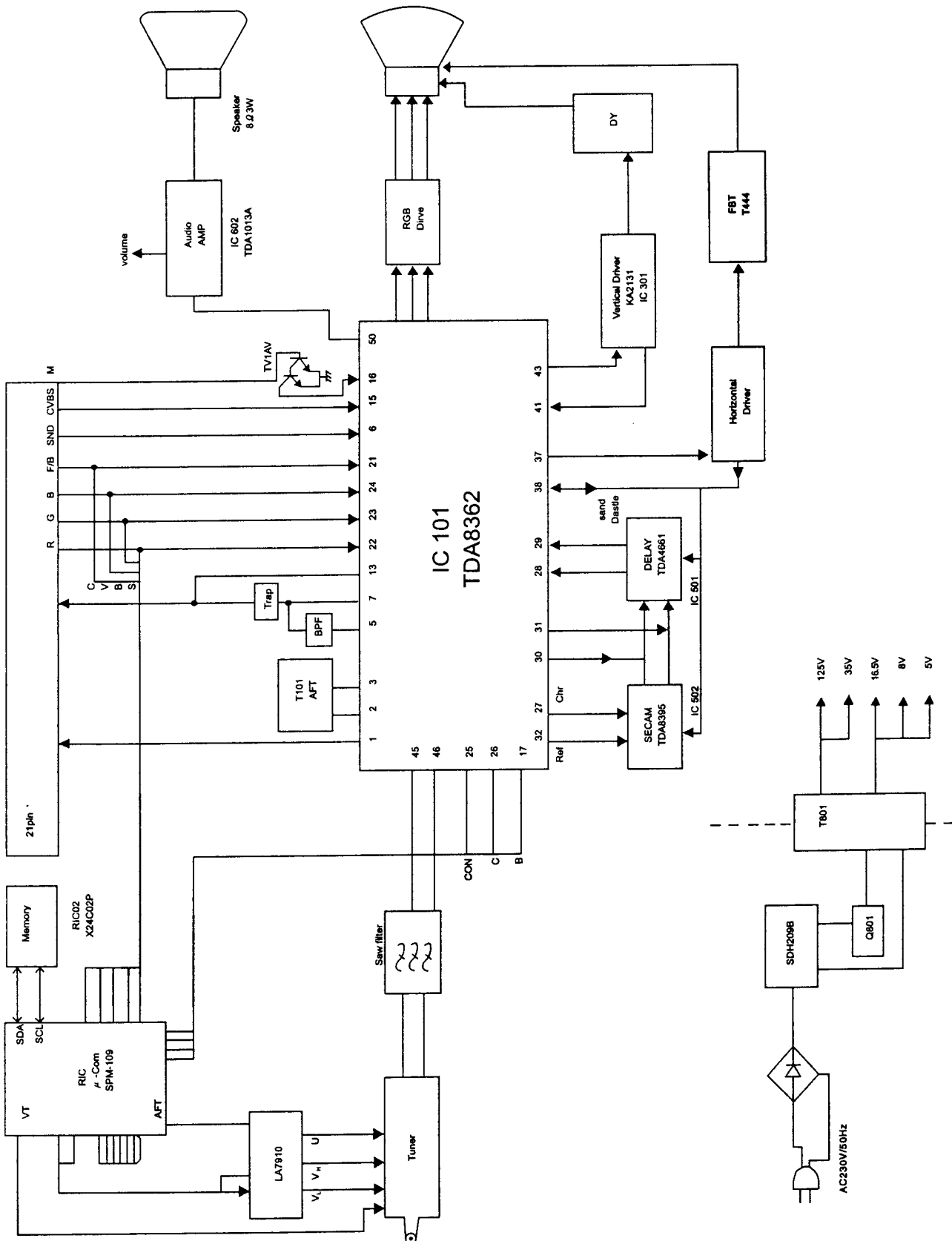



### 3. POWER SUPPLY SECTION

#### 1. BLOCK-DIAGRAM

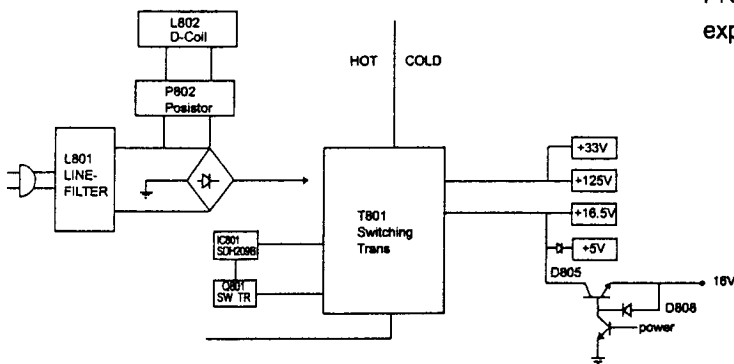

For Service Manuals Contact  
**MAURITRON TECHNICAL SERVICES**  
 8 Cherry Tree Rd, Chinnor  
 Oxon OX9 4QY  
 Tel:- 01844-351694 Fax:- 01844-352554  
 Email:- enquiries@mauritron.co.uk

#### 2. INTRODUCTION

The IC SDH209 controls the bipolar switching transistors and performs all necessary regulation and function in free running flyback converters.

The flyback converter is the most cost saving SMPS for CTV and VCR. But as the frequency goes up according to the increase of the input AC voltage and the reduction of power consumption an abnormal oscillation like intermittent oscillation or over voltage can happen easy unless the frequency rise is restrained.

SDH209 having a built-in mono-multi vibrator which is triggered at transistor switched off and generates a pulse of constant width to keep the transistor off for the pulse period, will keep switching frequency less than 120KHz.

SDH209 having a built-in constant DC current source will achieve the small drive power consumption at higher AC input and achieve the sufficient drive current at lower AC input.

Owing to the above two built-in circuits, SDH209 can get good regulation and high efficiency over a wide AC input range and keep stable oscillation at very small load.

In the standard connections, the constant voltage charged up at the capacitor is used and also used to sense voltage. So, the transformer and circuit are both simple.

Free running frequency of flyback converter is expressed by the following formula.

$$f = \frac{1}{2 \cdot LP \cdot PIN} \cdot \frac{V_{IN}^2}{\left(1 + \frac{ns}{np} \cdot \frac{VIN}{Vo}\right)^2}$$

where, LP Primary inductance

Pin : Input power

ns : Secondary winding turns

np : Primary winding turns

Vin : Input DC voltage

Vo : Output DC voltage

As the above formula, the frequency f goes up according to the increase of Vin and the decrease of Pin.

Mono-multi vibrator built-in SDH209 restrains the rise of switching frequency.

This mono-multi vibrator generates 4μsec pulse every end of Ton period.

That is, this mono-multi vibrator is triggered by signal which is produced when the transistor is switched off. The transistor is unable to be switched on again while the mono-multi vibrator's output is high.

While the transistor is off, the primary inductance of transformer and the floating capacitance or capacitor installed across the snubber diode compose a resonant loop and oscillate. This resonant frequency depends on the primary inductance and capacitance.

When 4μsec over, the transistor is released to be switched on again. The time of switch on is approximately 4μsec plus half cycle of resonant frequency from the time of switch off.

Capacitors installed across the snubber diode, across the secondary diodes and across C-E of the transistor affect to the resonant frequency. In order to obtain the stable stand-by oscillation, a total equivalent capacitance is recommended to be less than 330pF. Total equivalent capacitance Ceq is calculated.

$$Ceq = Csn + Cce + \left(\frac{ns_1}{np}\right)^2 \cdot Cs1 + \left(\frac{ns_2}{np}\right)^2 \cdot Cs2$$

where, Csn : Across the snubber diode  
 Cce : Across C-E of the transistor  
 np : Primary winding turns  
 ns1 : Secondary winding S1 turns  
 ns2 : Secondary winding S2 turns  
 Cs1 : Across the diode of S1  
 Cs2 : Across the diode of S2

**Remarks :** Capacitance includes a diode junction capacitance and a floating capacitance. Oscillation at no load is stable and its power loss is small because of the above mechanism.

**Operation of Over Load**

The formula of frequency f shows that f goes down when Vo is smaller than the rated value. When the switch is turned on, Vo starts from zero.

Therefore, the ordinary SMPS makes the whistle sound when starting up.

But, Ton limiter built-in SDH209B limits Ton duration regardless of Vo value.

So, no whistle is made at starting up.

This Ton limiter also works as a protector when the transistor is switching at the over load. Particularly when the input AC voltage is lower than the rated value, Ton becomes longer and the saturation loss increases. But Ton limiter stops becoming longer and protect the transistor from thermal run away.

**Operation at Output Short**

When the input AC voltage is higher than 220V. Ton limiter is not enough to protect the transistor from the over current. So, the current limiter is provided.

The instantaneous locus at the output short has not been taken clear in the picture. But the locus is expanded to 680V and 3.8A. Therefore, transistor's SOA is required bigger than this point. When the output short is further continued, the locus becomes shrinked and even a dead short will not destroy the transistor.

Because the constant DC current source for base drive is empty due to the dead short and then the transistor does not switch at a large current.

**Transformer**

1)Primary and Secondary Turn Ratio

The value of (Np/Ns) · Vo is factor to determine switching duty, Ic peak, Vce peak and frequency. The recommended value is like the below

$$\frac{n_p}{n_s} \cdot V_o \approx 220$$

2)Leakage Inductance

The recommended value is 1% of the primary inductance.

3)Magnetic Saturation Current

The recommended value is bigger than,

$$\frac{4 \times 10^{-3}}{L_p} + \frac{0.6}{r}$$

Where, Lp : Primary inductance (H)  
 r : Current sense resistor (Ω)

**3.IC SPECIFICATION (SDH209B)**

1)Block-Diagram

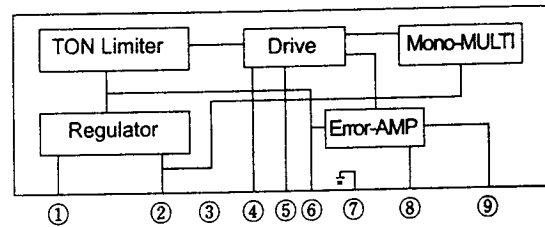

2)Electrical Characteristics (Ta=25°C)

Para-Meter	Symbol (unit)	Ratings			Remarks
		MIN	TYP	MAX	
Supply Voltage Range Pin1-2	V1(V)		+10.4		
	V2(V)	-3.0		-18.0	
Output Current	I3 (mA)		73		
Reference Voltage	V4 (V)	8.5	8.8	9.1	
Reference Voltage Ambient Temperature	Kt(mV/°C)		-3.0		
Mono Multi Frequency	T1(μs)		7.5		
Ton Limit	T2(μs)	18	22	26	
Current protection	V8 (V)		-0.6		
Reference Voltage Adjust Range	V4 (V)	8.0		10.0	

# 4. CHROMA, VIDEO, IF, SOUND, DEFLECTION SECTION

## 1. IC SPECIFICATION (TDA8362)

### 1) Introduction

#### a) General Description

Vision IF amplifier, video demodulator, video amplifier, AGC and AFC are suitable for both negative and positive modulation.

Sound limiter, demodulator and amplifier with volume control.

Inputs and switches for external audio and CVBS signals. Synchronization circuit with drive circuits for horizontal and vertical deflection.

Separate supply pin for starting the horizontal oscillator from the main rectifier.

X-ray protection (combined with the 2<sup>nd</sup> phase detector pin).

PAL/NTSC colour decoder in which the chroma filters (bandpass and trap) and the luminance delay line have been integrated. The circuit has a separate chroma input and the filters can be switched-off so that S-VHS signals (via an external switch) can be applied to the IC.

For SECAM applications an (alignment-free) SECAM-decoder can be added to the IC.

Peaking circuit in the luminance channel.

RGB-output circuit with linear inputs for On-Screen

Character Display.

The supply voltage for the IC is 8 Volts. It is mounted in an S-DIL envelope with 52 pins.

#### b) Features

- Multi-standard vision IF circuit (positive and negative modulation)
- Multi-standard FM sound demodulator (4.5MHz to 6.5 MHz)
- Video and audio switches (CVBS int/ext, S-VHS and audio int/ext)
- Integrated chroma trap and bandpass filters (auto-calibrated)
- Luminance delay line integrated
- PAL/NTSC colour decoder with automatic search system
- Easy interfacing with the TDA 8395 (SECAM decoder) for multi-standard applications.
- RGB-control circuit with linear RGB inputs and fast blanking
- Horizontal synchronization with two control loops and an alignment-free horizontal oscillator Vertical count-down circuit and a vertical pre-amplifier
- Low dissipation (only 600 mW)
- Small amount of peripheral components compared with completion IC's.
- Only one adjustment (vision IF demodulator)

### 2) Block-Diagram

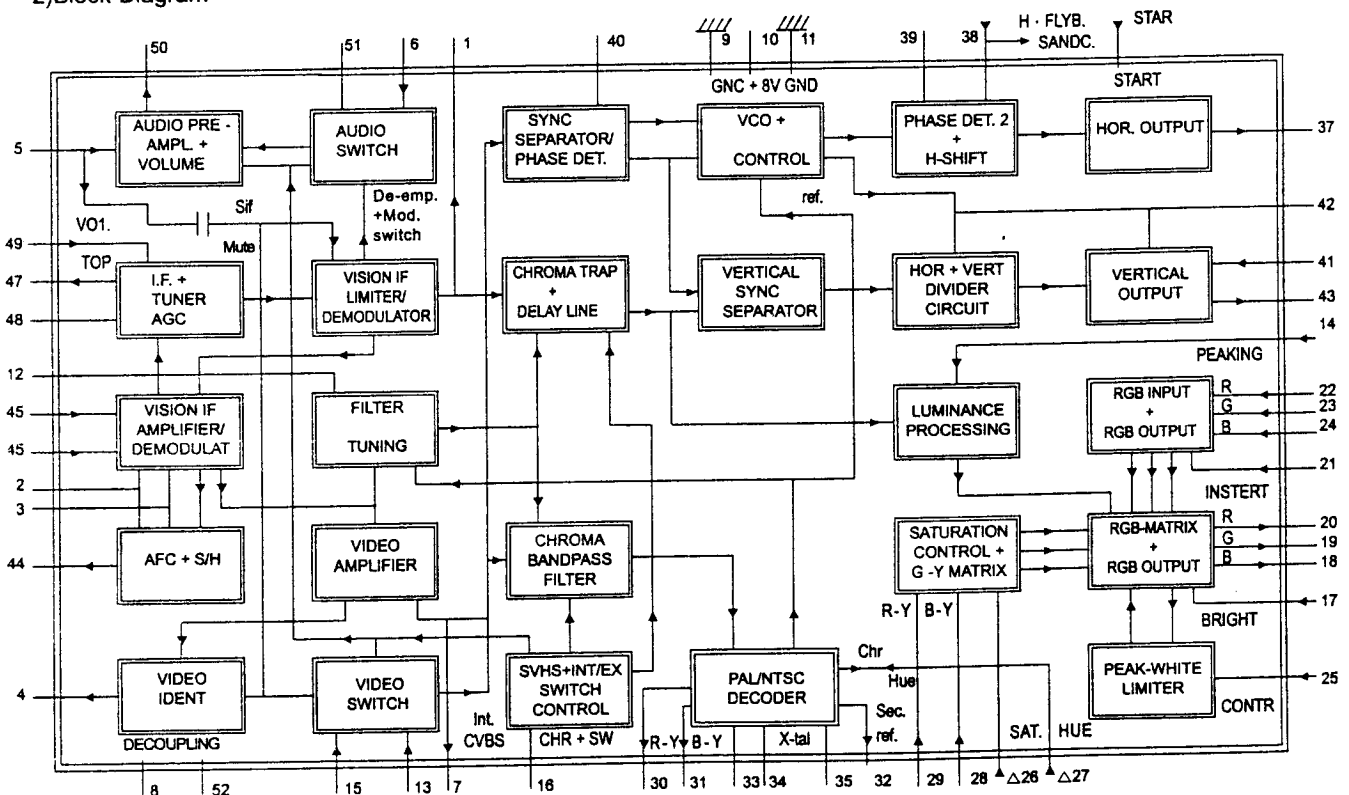

### 3) Pin Function

No	Function	No	Function
1	Audio deemphasis	52	Decoupling bandgap supply
2	IF-demodulator tuned circuit	51	Decoupling sound demodulator
3	IF-demodulator tuned circuit	50	Audio output
4	Video identification output	49	Tuner take-over adjustment
5	Sound IF in plus volume control	48	AGC decoupling capacitor
6	External audio input	47	Tuner AGC output
7	IF video output	46	IF-input
8	Decoupling digital supply	45	IF-AFC output
9	Ground	44	AFC output
10	Positive supply (8 V)	43	Vertical output
11	Ground	42	Vertical ramp generator
12	Decoupling filter tuning	41	Vertical feedback input
13	Internal CVBS input	40	$\phi$ -1 loop filter
14	Peaking control input	39	$\phi$ 1- loop filter
15	External CVBS input	38	Flyback input / sandcastle output
16	Chroma + A/V switch input	37	Horizontal output
17	Brightness control input	36	Start horizontal oscillator
18	B-output	35	4.43MHz X-tal connection
19	G-output	34	3.58MHz X-tal connection
20	R-output	33	Loop filter burst phase detector
21	RGB-insertion and blanking input	32	4.43MHz output for TDA 8395
22	R-input for insertion	31	B-Y output signal
23	G-input for insertion	30	R-Y output signal
24	B-input for insertion	29	R-Y input signal
25	Contrast control input	28	B-Y input signal
26	Saturation control input	27	Hue control input (or chroma out)

## 2. CHROMA VIDEO SECTION

### 1) Block-Diagram

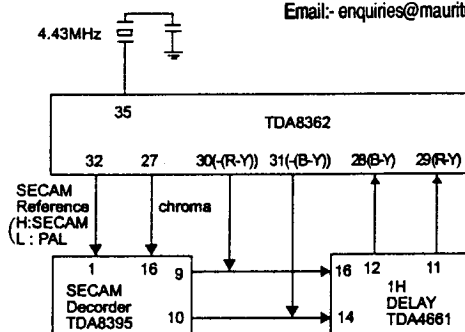

For Service Manuals Contact  
**MAURITRON TECHNICAL SERVICES**  
 8 Cherry Tree Rd, Chinnor  
 Oxon OX9 4QY  
 Tel:- 01844-351694 Fax:- 01844-352554  
 Email:- enquiries@mauritron.co.uk

### 2) Actuating Description

#### - Colour Decoder

The colour decoder contains an alignment-free X-tal oscillator, a dual killer circuit and the colour difference signals demodulators. The decoder adapts automatically for PAL and NTSC signals. Two X-tal pins are present so no external switching is required. With the SECAM add-on decoder TDA8395 an alignment free multi-standard

decoder can be built with an automatic selection. This makes the application of the TDA8362 very flexible. The following applications are possible:

#### - PAL/SECAM:

In this application pin 27 is not used for Hue-control but for the chroma signal for the SECAM add-on circuit. Pin 27 has to be connected to the supply line 8V via a series resistor of 10k $\Omega$ . Together with the alignment-free SECAM add-on circuit TDA8395 a PAL/SECAM decoder is realized.

The burst phase detector locks the X-tal oscillator with the burst signal. Two gain modes provide an increased catching range when the PLL is unlocked and a low ripple voltage and a good noise immunity when the PLL is locked.

The burst phase detector operates during the burst key period only, to prevent the PLL from being disturbed by the chroma signal.

The killer circuit switches off the R-Y and B-Y demodulators at too low input signal condition (burst amplitude). Proper hysteresis prevent the constant on/off switching at a certain input level.

### 3) IC Block-Diagram (TDA8362)

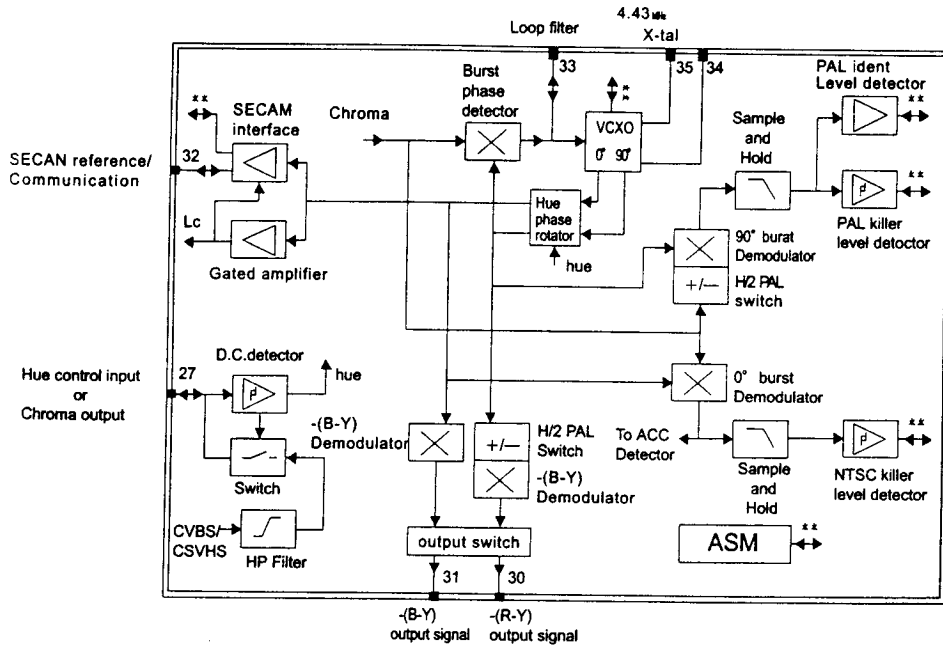

### 4) IC Specification (TDA8395)

#### a) Introduction

The TDA8395 is an alignment-free SECAM colour decoder and can be used in conjunction with the TDA8362. It includes the Cloche filter, demodulator and identification circuit. The TDA8395 application needs very few external components, the deemphasis is internally calibrated.

The cloche filter is a gyrator-capacitor type filter. Its resonance frequency is controlled during the calibration period and offset during scan for the right resonance frequency. The required reference frequency for calibration must be connected at pin 1 and is obtained from the TDA8362 (pin 32).

The two (or three)-level sandcastle pulse has to be connected at pin 15 (TDA8362 pin 38) and is used for

blanking periods and provides the clock information for the identification circuit.

The chroma signal at pin 16 connected to pin 27 of TDA8362, is demodulated by a PLL demodulator, which uses the reference frequency and a bandgap reference to force the PLL to the desired demodulation characteristic. Digital line identification is implemented to check the incoming signal for SECAM. If SECAM is detected, pin 1 will sink a current of  $150\mu\text{A}$ . Together with the TDA8362 the voltage at this pin will become high (5.5V). In this case the colour difference signal outputs will be switched on. These outputs will be disconnected and the high-ohmic when no SECAM is detected for two frame periods, the demodulator will be initialized before trying again.

#### b) Block-Diagram

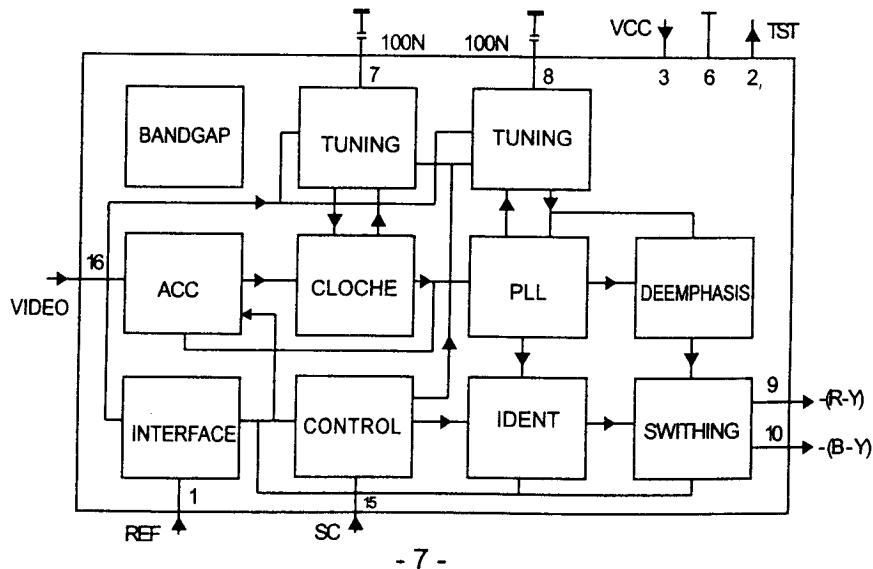

c) Pin Function

No	SYMBOL	Function
1	$f_{ref}/IDENT$	reference frequency input/identification input
2	TEST	test output
3	Vp	positive supply voltage
4	n.c.	not connected
5	n.c.	not connected
6	GND	ground
7	CLOCHEref	Cloche reference filter
8	PLLref	PLL reference
9	- (R-Y)	- (R-y) output
10	- (B-Y)	- (B-Y) output
11	n.c.	not connected
12	n.c.	not connected
13	n.c.	not connected
14	n.c.	not connected
15	SAND	sandcastle pulse input
16	CVBS	video (chrominance) input

TDA8362 and TDA8395 without the need of switches and alignments. The TDA4661 consists of two main blocks:

-Two comb filters with a delay time of  $64\mu$  sec in switched capacitor technique.

-Internal clock generation of 3MHz, line locked via the sandcastle pulse.

The TDA4661 operates according to the mode demanded by the colour transmission standard. In the PAL mode it operates as a geometric adder to satisfy the requirements of PAL demodulation, in the NTSC mode it reduces the cross-colour interference (comb-filtering) and in the SECAM mode the delay line repeats the colour difference signal on consecutive horizontal scan lines.

The colour difference signals are AC-coupled to pin 14 and 16 and clamped by the input stages. The internal clock drives the delay lines to obtain the required  $64\mu$  sec. The clock pulses are derived from a 6MHz Current Controlled Oscillator which is the line locked via a PLL with the sandcastle pulse, connected at pin 5. Sample and hold low pass filters suppress the clock signal. The delayed and the un-delayed signals are added, buffered and fed to the output pins 11 and 12.

5) IC specification (TDA4661)

a) Introduction

The TDA4661 are integrated the baseband delay lines of  $64\mu$ S for colour television receivers. It can be connected to the

b) Block-Diagram

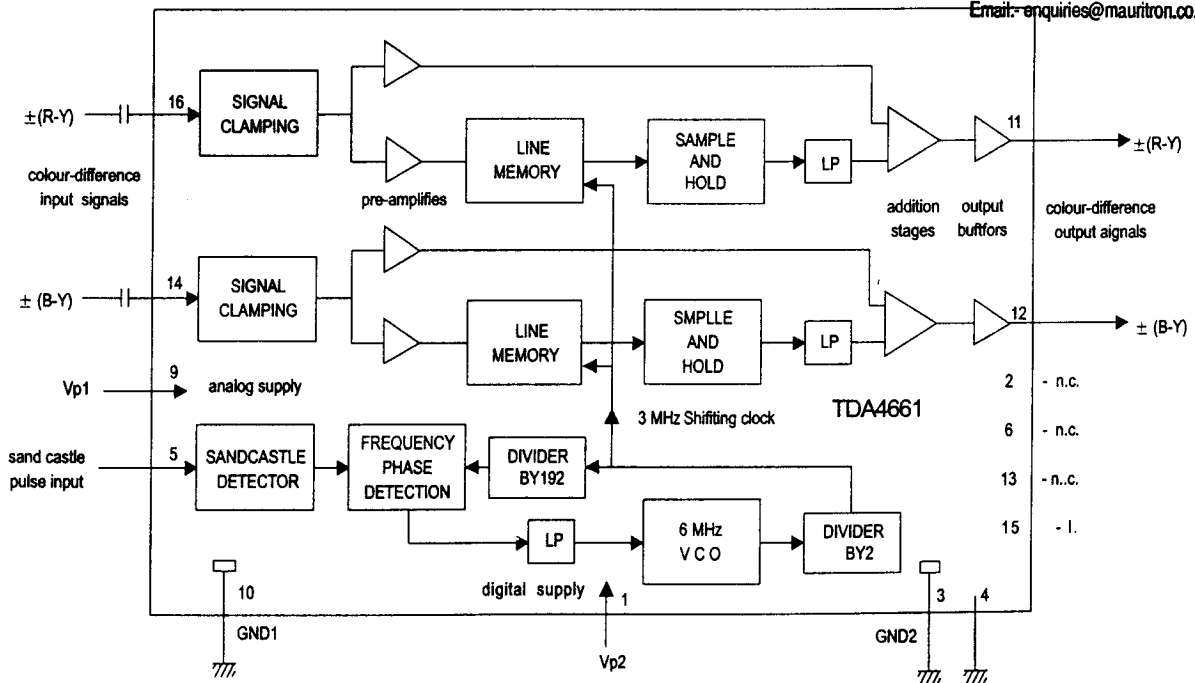

For Service Manuals Contact  
**MAURITRON TECHNICAL SERVICES**  
 8 Cherry Tree Rd, Chinnor  
 Oxon OX9 4QY  
 Tel:- 01844-351694 Fax:- 01844-352554  
 Email:- enquiries@mauritron.co.uk

### c) Pin Function

No	Symbol	Function	No	Symbol	Function
1	Vp2	+8V Supply Voltage for analogue part	9	Vp1	+8V Supply Voltage for analogue part
2	n.c.	not connected	10	GND1	ground for analog part(0V)
3	GND2	ground for digital part(0V)	11	Vo(R-Y)	± (R-Y) output signal
4	i.c.	internally connected	12	Vo(B-Y)	± (B-Y) output signal
5	SAND	Sandcastle pulse input	13	n.c.	not connected
6	n.c.	not connected	14	Vi(B-Y)	± (B-Y) input signal
7	i.c.	internally connected	15	n.c.	not connected
8	i.c.	internally connected	16	Vi(R-Y)	± (R-Y) input signal

### 3. IF SECTION

#### 1) Block-Diagram

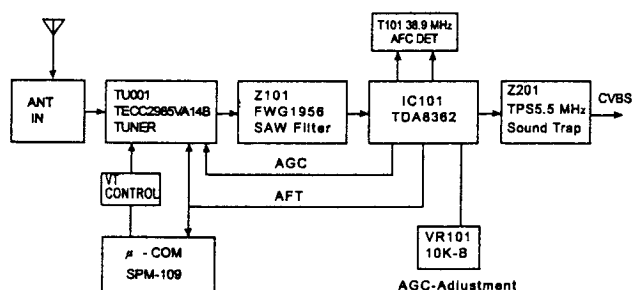

#### 2) Actuating Description

##### a) IF amplifier

The IF-amplifier contains 3 AC-coupled control stages with a total gain control range which is in excess of 60 dB. The sensitivity of the circuit is comparable with that of modern IF-IC's. The reference carrier for the video demodulator is obtained by means of the passive regeneration of the picture carrier. The external reference tuned circuit is the only remaining adjustment of the IC. The polarity of the demodulator can be switched so that the circuit is suitable for both positive and negative modulated signals.

The AFC-circuit is driven with the same reference signal as the video demodulator. To avoid that the video content

disturbs the AFC operation a sample-and-hold circuit is applied. The capacitor for this functions is internal. The AFC output voltage range is 6 Volts.

The AGC-detector operates on top-sync or top white-level depending on the position of the demodulator. The AGC detector time-constant capacitor is connected externally. This is mainly because of the flexibility of the application. The time-constant of the AGC system during positive modulation is rather longer to avoid visible variations of the signal amplitude. To obtain an acceptable speed of the AGC system a circuit has been included which detects whether the AGC detector is activated every frame period. When 3 frame periods no action is detected, the speed of the system is increased.

The circuit contains a video identification circuit which is independent of the synchronization circuit. Therefore the search tuning is possible when the display section of the receiver is used as a monitor. The ident output voltage is low when no transmitter is identified. In that condition the sound demodulator is switched off (mute function). When a transmitter is identified the voltage is high. The voltage level is dependent on the frequency of the incoming chroma signal.

##### b) AGC Tuner AGC and AFC

The A.G.C. detector operates at top-sync level for signals with negative modulation and at peak-white level for positive modulated signals. This A.G.C. detector is gated for negative modulated signals to reduce the sensitivity of impulsive noise.

The time constant capacitor (C117) is connected externally at pin 48. For positive modulated signals the A.G.C. time constant is long to avoid visible variations of the video output signal. To obtain an acceptable A.G.C. speed with positive modulation an extra circuit checks whether the A.G.C. detector is activated every frame period. The speed will be increased if this circuit detects that the video output signal has not reached 80% of peak white level for approximately 100mS.

The tuner AGC take-over point can be set by adjusting the DC-voltage at pin 49, with a potentiometer of 10 kΩ (VR101).

The tuner A.G.C. (pin 47) is an open collector output stage with an output swing of 2mA min. The voltage swing, required by the tuner, can be obtained with an external resistor network, connected at pin 47. Pin 47 may rise 2V above the actual supply voltage, without damaging the IC.

This feature simplifies the application, because most

tuners require a 9V A.G.C. voltage level for min. gain.

The A.F.C. circuit is driven by the same reference signal as the video demodulator. A sample and hold circuit avoids video break-through from the video demodulator to the A.F.C. voltage. The A.F.C. output voltage range is from 0 to Vcc, the stepness of the A.F.C. slope can be influenced by resistors R114 and R115.

### 3) IC Block-Diagram (TDA8362)

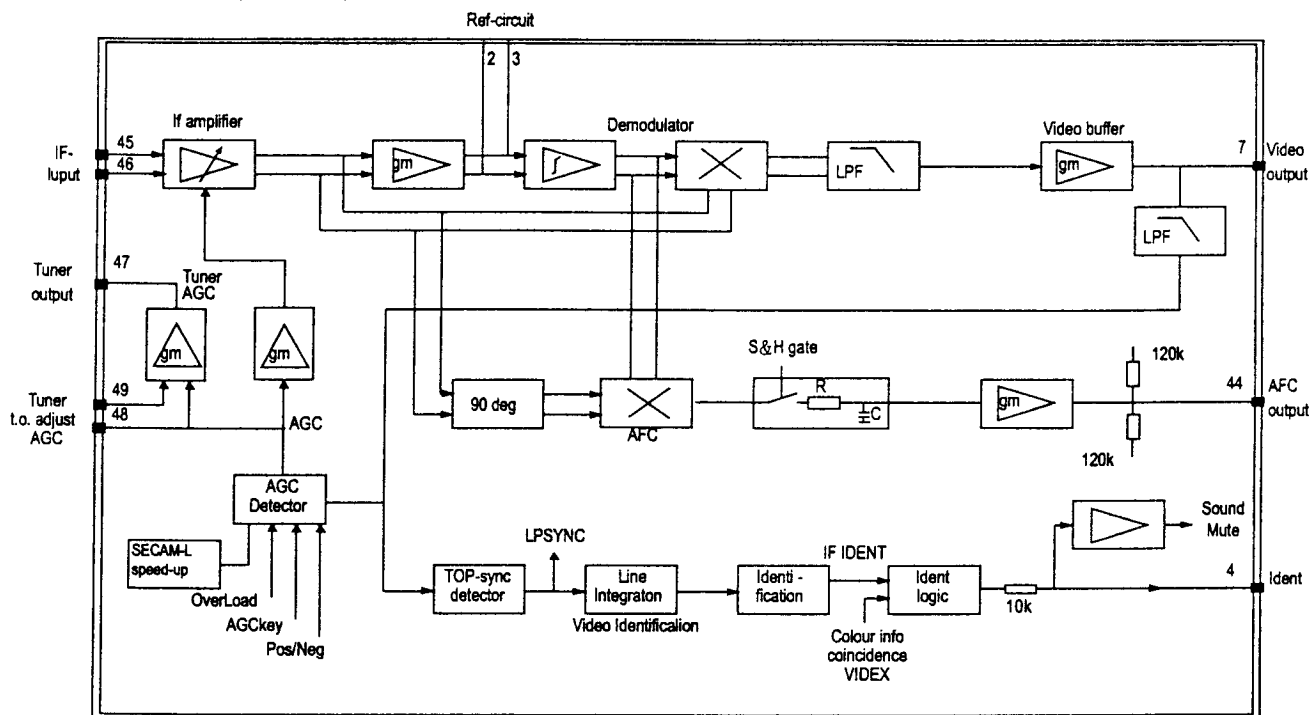

### 4. SOUND SECTION

#### 1) Block-Diagram

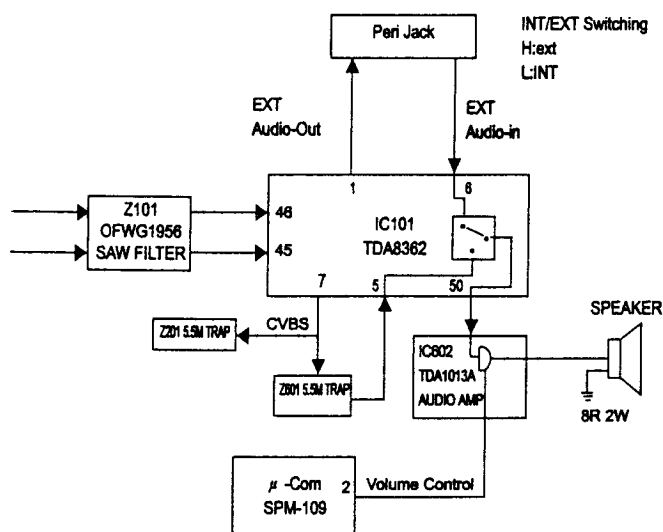

#### 2) Actuating Description

The sound bandpass and trap filters have to be connected externally. The filtered intercarrier signal is fed to a limiter circuit and is demodulated by means of a PLL demodulator. This PLL circuit itself tunes automatically to the incoming signal so that no adjustment is required.

The volume is DC-controlled. The composite audio output signal has the amplitude of 700mV RMS at maximum volume control setting. The deemphasis capacitor has to be connected externally. The non-controlled audio signal can be obtained from this pin (via a buffer stage). The amplitude of this signal is 350mV RMS. The external audio input signal must have an amplitude of 350mV RMS. The audio/video switch is controlled via the chroma input pin.



Audio input signal from an external source (SCART) with an amplitude up to 350mVrms (+/- 6 dB) can be fed to pin 6. The audio switch is controlled via the chroma input pin 16, as described in Chapter 2.1.8. The volume control operates upon the external audio input signal, when the

TDA8362 is switched to the external mode.

When the TDA8362 is switched for video signals with the positive modulation, the demodulated AM-sound signal can be connected to the external audio input at pin 6 under the operation of the volume control.

### 3) IC Block-Diagram (TDA8362)

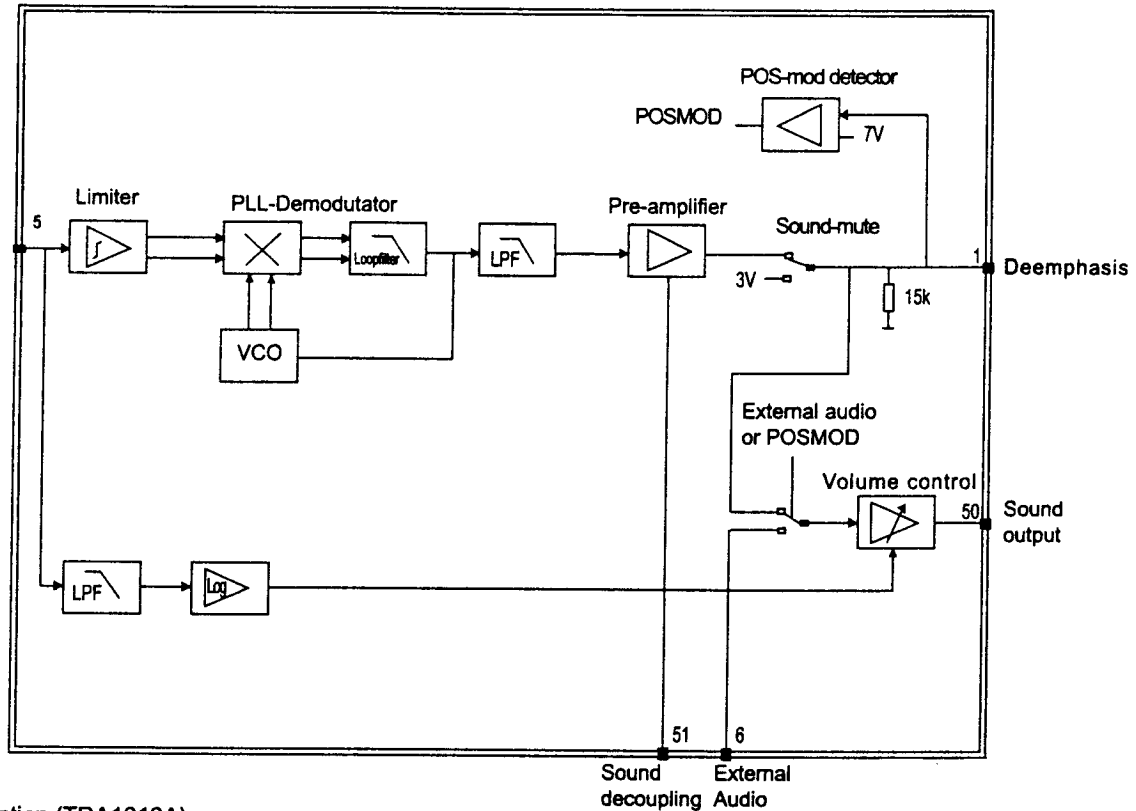

### 4) IC Specification (TDA1013A)

#### a) Introduction

The TDA1013A is a monolithic integrated audio amplifier circuit with D.C. volume control in a 9-lead single in-line (SIL) plastic package. The wide supply voltage range makes this circuit very suitable for applications in mains fed apparatus such as television receivers and record players.

The D.C. volume control stage has a logarithmic control characteristic with a range of more than 80 dB; control can be obtained by means of a variable D.C. voltage between 3.5 and 8 V.

The audio amplifier has a well defined open loop gain and a fixed integrated closed loop gain. This offers an optimum in number of external components, performance and stability.

The SIL package (SOT-110B) offers a simple and low-cost heatsink connection.

#### b) Block-Diagram

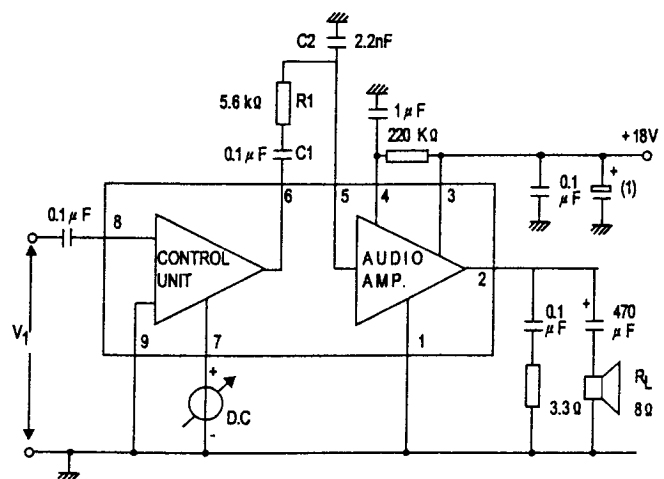

## 5.DEFELECTION SECTION

### 1)Block-Diagram

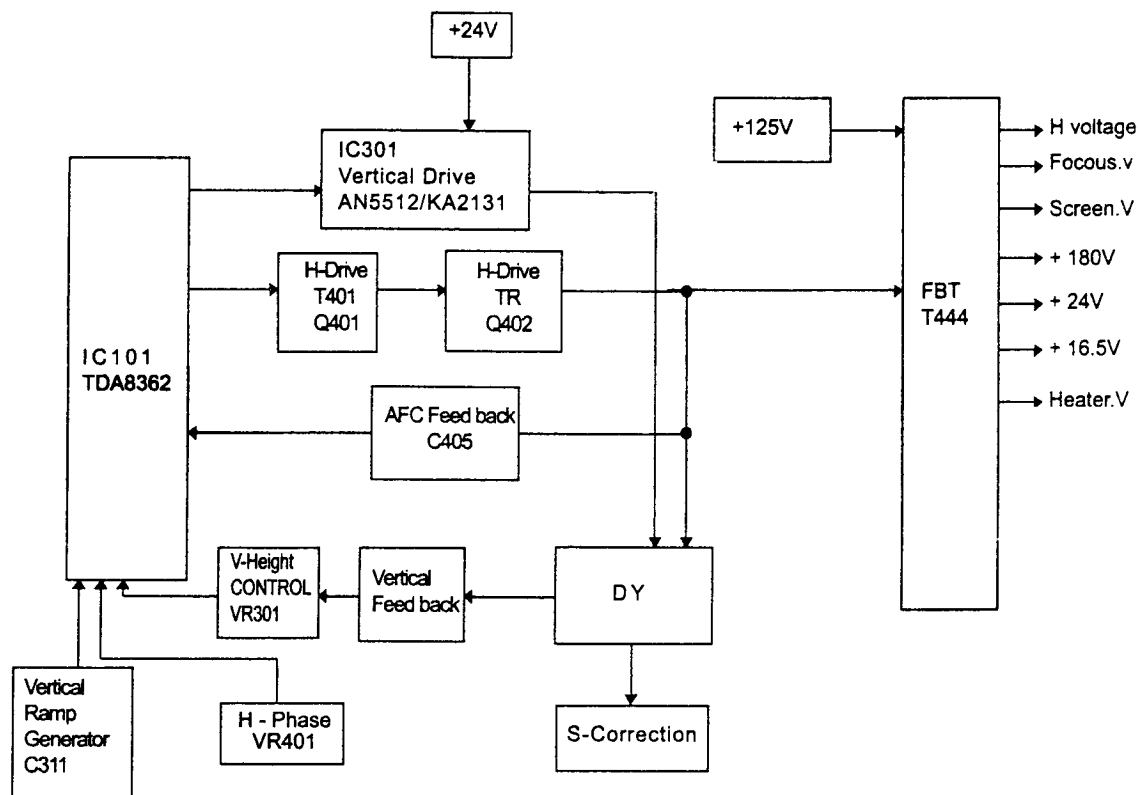

### 2)Actuating Description

The incoming video signals, pin 13 for the internal signal and pin 15 for an external CVBS signal, are fed to the synchronization separator circuit. Internally the black level and the top sync. level are detected, next the synchronization pulses are amplified to a fixed level and sliced at 50% of that level. In this way a very good synchronization performance is obtained. The separated synchronization pulses are fed to the first phase detector circuit and to the coincidence detector. The components which determine the loop gain of the first phase detector are connected at pin 40 (C401, C402 and R402). The coincidence detector is only used to detect whether the line oscillator is synchronised, not for transmitter identification.

The line oscillator is running at twice the line frequency and is derived from the X-tal oscillator frequency of the colour decoder, consequently no adjustment is required. The free-running frequency has a maximum deviation of 2% compared to the nominal frequency.

The second phase detector generates the pulses for the horizontal driver stage (pin 37).

The loop filter capacitor (C404) is connected at pin 39. Horizontal shift can be obtained by a potentiometer and series resistor (R401 and R402) connected at pin 39.

The TDA8362 has a separate start-up circuit for the horizontal oscillator (pin 36). In case this feature is used for starting the horizontal deflection the resistor connected at the base of the horizontal driver transistor (Q401) must be connected to the start supply as well (pin 37 is an open collector). For applications which do not require a start-up function pin 36 must be connected to the main supply voltage (8V).

The vertical drive pulses (pin 43) are generated by a divider circuit. The vertical ramp generator components are connected at pin 42. Capacitor C311 is charged via two resistors, one resistor connected to a stabilized supply voltage (R313). In this way the vertical amplitude will be kept constant with different picture contents.

AC and DC feedback voltage from the vertical deflection stage must be connected at pin 41.

3) IC Block-Diagram (TDA8362)

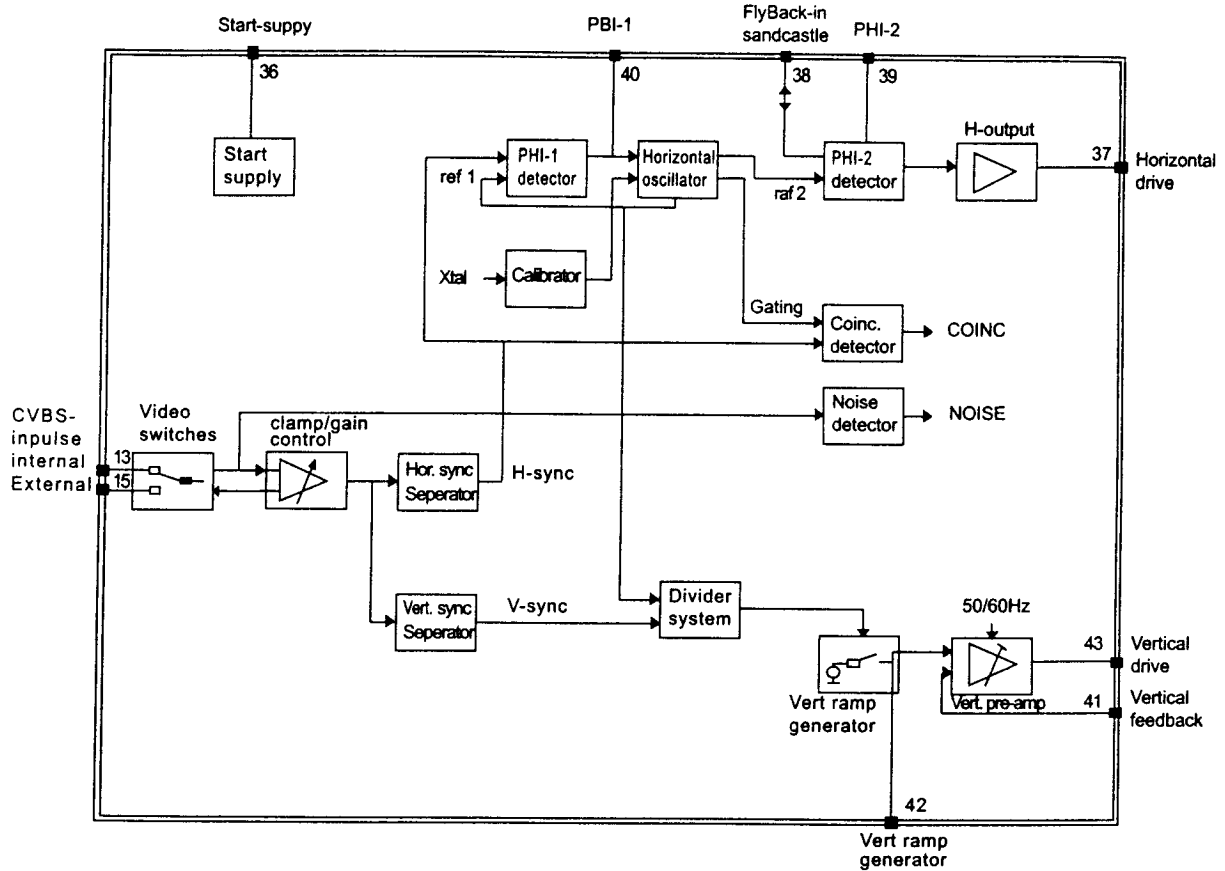

4) IC Specification (KA2131)

a) Introduction

The KA2131 is a monolithic integrated circuit designed for the vertical output stage in color television receivers.

- FUNCTIONS

- Driver stage.
- Output stage.
- Flyback generator.
- Pulse shaper.

- FEATURES

- Low power consumption, direct deflection coil driving capability (Flyback voltage is supplied two times as high as supply voltage during flyback period only).
- High breakdown voltage : 60V

b) Block-Diagram

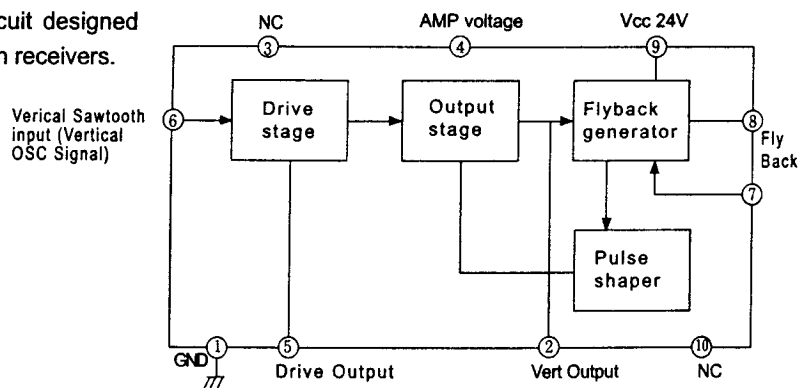

# 5.REMOCON SECTION

## 1.INTRODUCTION

CTV340S(SPM 109B) is a low cost television receiver control system bases on the PCA84C641 microcontroller. It is a voltage synthesis tuning (VST) system which can be used all over the world. All relevant control functions of the system are displayed via the on-screen display circuitry of the microcontroller. Herewith two independent lines of 16 characters with 4 different sizes and in 7 different colours can be displayed. All analogue picture settings are controlled with 4 on-chip digital to analogue convertors. The fifth digital to analogue converter can be used for volume in a mono-only option, or full sound (Voume, Bass, Treble, Balance) can be controlled in a German Stereo and/or Nicam sound configuration. This system is colour standard independent.

A four page teletxt system, based on the VIP2(SAA5231), ECCT(SAA5243) and display memory, can be controlled indirectly via a second microcontroller. This offers the possibility of a sophisticated teletext system with special features like FASTEXT, TOP, LIST, packet X/26 decoding (for Spain and Eastern Europe).A minimum amount of

software is spent to transfer the teletxt commands from the remote control to this special teletext controller. A second option is a system with no teletext at all. The CTV340S(SPM109B) system fulfils a numerous and varied requirements and has options to make it applicable to all markets.

- Definitions, acronyms and abbreviations.

ACC	Analogue to Digital Converter
Peri	Peripheral TV signal source
CCT	Computer Controlled Teletext decoder
DAC	Digital to Analogue Converter
I <sup>2</sup> C	Inter IC bus, 2-wire bidirectional multimaster bus
IDENT	horizontal coincidence signal, transmitter IDENTification
NV-memory	Non-Volatile memory
OSD	On Screen Display
PP	Personal Rreference, preferred analogue values
RC-5	Remote Control system, according RC-5 world standard
VST	Voltage Synthesis Tuning
VTR	Video Tape Recorder time constant

MEMO .....

.....

.....

.....

.....

.....

.....

.....

.....

.....

.....

.....

.....

.....

.....

.....

MEMO .....

.....

.....

.....

.....

.....

.....

**For Service Manuals Contact**  
**MAURITRON TECHNICAL SERVICES**  
**8 Cherry Tree Rd, Chinnor**  
**Oxon OX9 4QY**  
**Tel:- 01844-351694 Fax:- 01844-352554**  
**Email:- enquiries@mauritron.co.uk**

.....

.....

.....

.....

.....

## 2. BLOCK-DIAGRAM

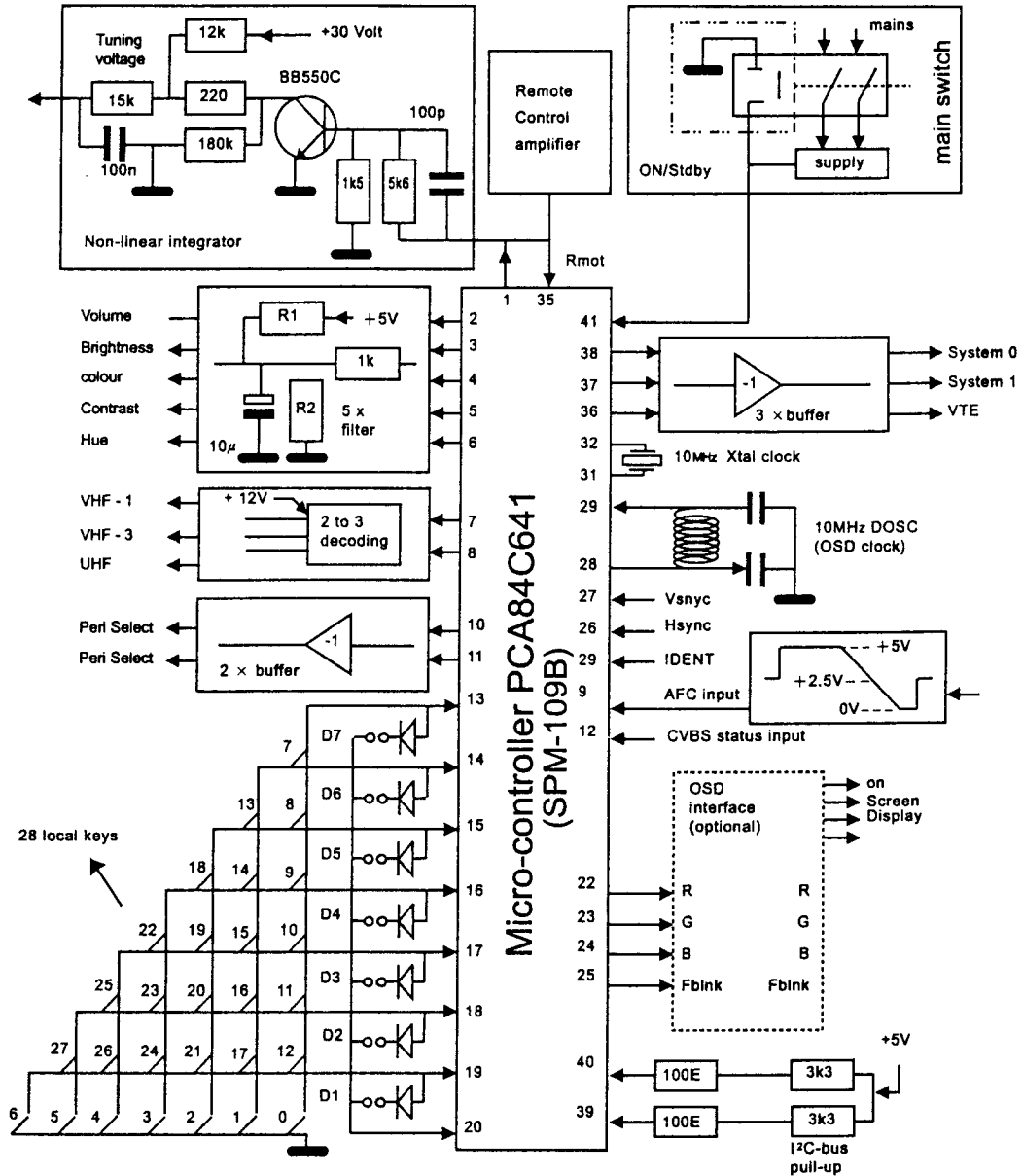

## 3. PIN FUNCTION

No	Symbol	Function	No	Symbol	Function
1	VTUNN	tuning voltage control output	11	Peri1	Peri output 1
2	VOL	volume control output in mono-only option	12	CVBS in	CVBS status input
3	BRI	brightness control output	13	KEYB0	keyboard scan line input/output
4	COL	colour control output	14	KEYB1	keyboard scan line input/output
5	CON	contrast control output	15	KEYB2	keyboard scan line input/output
6	HUE/	hue control output	16	KEYB3	keyboard scan line input/output
7	BND-0	band-switch output 0	17	KEYB4	keyboard scan line input/output
8	BND-1	band-switch output 1	18	KEYB5	keyboard scan line input/output
9	AFC	analogue AFC sense input	19	KEYB6	keyboard scan line input/output
10	Peri0	Peri output 0	20	MDSTR	system mode strobe output

No	Symbol	Function	No	Symbol	Function
21		ground supply input	32		oscillator output
22	RED	OSD red output	33		power-on reset input/output
23	GREEN	OSD green output	34	SND1	horizontal coincidence input
24	BLUE	OSD blue output	35	RMOT	remote control input
25	FBL	OSD fast blanking output	36	VTR	VTR time constant control output
26	HSYNC	horizontal synchronization input	37	Sys1	system output 1
27	VSYNC	vertical synchronizatin input	38	Sys0	system output 0
28	DOSCOUT	LC oscillator output for OSD	39	SCL	I <sup>2</sup> C - bus clock signal input/output
29	IDENT	LC oscillator input for OSD	40	SDA	I <sup>2</sup> C - bus data signal input/output
30		test input; connected to ground	41	STDBY	Standby/On control input/output
31		oscillator input; 10 MHz crystal	42		+5V supply voltage input

Notes:

- 1) These pins are read at "cold start", they define the configuration/options of the TV-system
- 2) These pins can command a solenoid to switch-off AC-mains supply.

## 6.ALIGNMENT and ADJUSTMENT

- This Models has only one adjustment -

### 1.GENERAL INFORMATIONS

All the adjustments are thoroughly checked and corrected when the receiver leaves the factory. Therefore the receiver should operate normally and produce proper colour and B/W picture upon installation. However the minor service adjustments may be required depending on the particular location in which the receiver is operated. This receiver is shipped completely in carboard carton. Carefully draw out the carton and remove all the packing materials. Plug the power cord into a convenient two pin power outlet. Turn the receiver ON and adjust the fine tuning for the best picture detail. Check and adjust all the customer controls such as BRIGHTNESS, CONTRAST and COLOUR Controls to obtain natural colour or B/W picture.

### 2.AUTOMATIC DEGAUSSING

A degaussing coil is mounted around the picture tube so that the external degaussing after moving the receiver is nomally unnecessary, providing the receiver is properly degaussed upon installation. The degaussing coil operates for about 1 second after the power to the receiver is switched ON. If the set is moved or faced in a different direction, the power switch must switch off at least 10 minutes in order that the automatic degaussing circuit is operated properly.

If the chassis or parts of the cabinet becomes magnetized and cause poor colour purity, use an external degaussing coil.

Slowly move the degaussing coil around the face-plate of the picture tube, the sides and the rear of the receiver and slowly withdraw the coil to the distance of about 2m before disconnecting it from the AC source. If the colour shading still persists, perform the COLOUR PURITY ADJUSTMENT and CONVERGENCE ADJUSTMENTS procedures, as mentioned later.

### 3.HIGH VOLTAGE CHECK

CAUTION : There is no HIGH VOLTAGE ADJUSTMENT on this chassis. But B+ power must be adjusted in +125V under the full colour bar pattern and nomal picture control level.

- 1)Connect an accurate high voltage meter to the second anode of the picture tube.
- 2)Turn on the receiver. Set the BRIGHTNESS and CONTRAST control to minimum(Zero beam).
- 3)The high voltage should be measured less.
- 4)Rotate the BRIGHNESS and CONTRAST control to the both extremes to be sure. The high voltage does not exceed the limit under any conditions.

### 4.HORIZONTAL PHASE ADJUSTMENT

If you want to move the center of picture, adjust HORIZONTAL phase control(VR401)

## 5. VERTICAL HEIGHT ADJUSTMENT

The SIZE control (VR301) on the main board changes the size of the picture, having an equal effect on the top and the bottom.

## 6. SCREEN ADJUSTMENT

- 1) Tune in an active channel.
- 2) Make the picture normal condition (no blooming or no-flyback line) with the VR screen.

## 7. FOCUS ADJUSTMENT

Adjust the FOCUS control on FBT for well defined scanning lines in the center area of the screen.

## 8. R-F AGC ADJUSTMENT

- 1) Tune the set in the strongest station in your area.
- 2) Turn the AGC control (VR101) on the IF board to fully clockwise position.
- 3) Adjust the AGC control until noises (snow) disappear from the screen.

## 9. COLOUR PURITY ADJUSTMENT

NOTE : Before attempting any purity adjustments, the receiver should be operated for at least fifteen minutes. Purity adjustment requires Rubber Wedge kit.

- 1) Demagnetize the picture tube and cabinet using a degaussing coil.
- 2) Turn the CONTRAST and BRIGHTNESS controls to the maximum.
- 3) Receive the green colour pattern.
- 4) Loosen the clamp screw holding the yoke, and slide the yoke backward or forward to provide the vertical green belt (zone) in the picture screen.
- 5) Remove the Rubber Wedges.
- 6) Rotate and spread the tabs of the purity magnet (See Fig.3) around the neck of the picture tube until a green belt is obtained in the center of the screen. And at the same time, center the raster vertically by adjusting the magnet.
- 7) Move the yoke slowly forward or backward until a uniform red screen is obtained. Tighten the clamp screw.
- 8) Check the purity of the red and blue raster.
- 9) Tighten the clamp screw of the yoke temporarily.
- 10) Obtain a white raster ; referring to the "CRT WHITE BALANCE ADJUSTMENT".
- 11) Proceed with convergence adjustment.

## 10. CRT WHITE BALANCE ADJUSTMENT

- 1) preparation
  - a) Operate the receiver for at least 20 minutes before attempting the white balance adjustment.

- b) Receive a black and a white signals (Lion head pattern is better)
- c) Set the colour control to the center position.
- d) Set the brightness and contrast controls to the maximum position.
- e) Set the red, blue and green low light controls to the mechanical center position.
- f) Set the blue and red drive controls to the mechanical center position.
- g) Set the screen VR control on FBT to the minimum position (fully counter - clockwise).
- h) Connect 1 to 2 and 3 to 4 in CN202.

## 2) STEPS

- a) Rotate the SCREEN control on FBT (T444) gradually clockwise until the first horizontal line appears slightly on the screen.
- b) Adjust the two CUT - OFF controls to obtain the slightly lighted horizontal line in the same levels of three colours (red, green, blue). The line look like white if the CUT - OFF controls are adjusted properly.
- c) Reset the CN202 on the MAIN board to obtain a raster ("NORMAL" Position).
- d) Adjust the blue and red drive controls to obtain proper white - balanced picture in high light areas.
- e) Set the contrast control to the minimum position and turn the brightness control slightly counterclockwise to obtain a dark gray raster. Then check the white balance in low brightness. If the white balance is not enough, repeat steps 1) - 4) for the correct white balance.

## 11. CONVERGENCE ADJUSTMENTS

NOTE : Before attempting any convergence adjustment, the receiver should be operated for the least fifteen minutes.

- 1) Center Convergence Adjustment
  - a) Receive the crosshatch pattern with a colour bar signal generator.
  - b) Adjust the BRIGHTNESS and CONTRAST Controls for a well defined pattern.
  - c) Adjust the two tabs of the 4-pole Magnets to change the angle among them (See Fig.2) and superimpose the red and the blue vertical lines in the center area of the picture screen. (See Fig.2).
  - d) Turn the both taps while at the same time keeping angle constant and superimpose the red and the blue horizontal lines at the center of the screen. (See Fig. 3).
  - e) Adjust the two tabs of 6-pole Magnets to superimpose the red/blue line and green one. Adjust the angle to affect the vertical lines and

rotate both magnets to affect the horizontal lines.  
 f)Due to the interaction between these adjustments the steps 3,4 and 5 should be repeated until the satisfactory results are obtained.

2)Circumference Convergence Adjustment

- a)Loosen the clamping screw of deflection yoke to allow the yoke to tilt.
- b)Put a wedge as shown in Fig. 1 temporarily. (Do not remove the cover paper on adhesive part of the wedge).
- c)Tilt front of the deflection yoke up or down to obtain better convergence in circumference. (See Fig.3) Push the mounted wedge into the space between the picture tube and the yoke to fix the yoke temporarily.
- d)Put the other wedge into bottom space and remove the cover paper to stick.
- e)Tilt the front of the yoke right of left to obtain the convergence in circumference. (See Fig.3)
- f)Keep the yoke position and put another wedge in either upper space. Remove the cover paper and stick the wedge on picture tube to fix the yoke.

- g)Detach the temporarily mounted wedge and put in another upper space. Stick it an picture tube to fix the yoke
- h)After fixing three wedges recheck overall convergence. Tighten the screw firmly to fix the yoke and check the yoke is firm.
- i)Stick 3 adhesive tabs on wedges as shown in Fig. 1.

12.VIF (SIF) ADJUSTMENT

1)Equipment

- Pattern generator (PM5518)
- Digital Voltmeter

2)Preparation

- a)Set the supply voltage to AC 220V
- b)Set the RF output frequency of Gen to 38.9MHz and then Multi-burst pattern.
- c)Connect the RF out of PM5518 to Tuner's Pin (IF)
- d)Connect the DC volts-meter to J106
- e)Adjust the DC voltage of J106 tape 4V by controlling the T101.

MEMO

.....

.....

.....

.....

.....

.....

.....

.....

.....

.....

.....

.....

.....

.....

.....

.....

.....

.....

.....

.....

.....

.....

MEMO

.....

.....

.....

.....

.....

.....

.....

.....

.....

.....

.....

.....

.....

.....

.....

.....

.....

.....

.....

.....

.....

.....  
 For Service Manuals>Contact  
**MAURITRON TECHNICAL SERVICES**  
 8 Cherry Tree Rd, Chinnor  
 Oxon OX9 4QY  
 Tel:- 01844-351694 Fax:- 01844-352554  
 Email:- enquiries@mauriton.co.uk



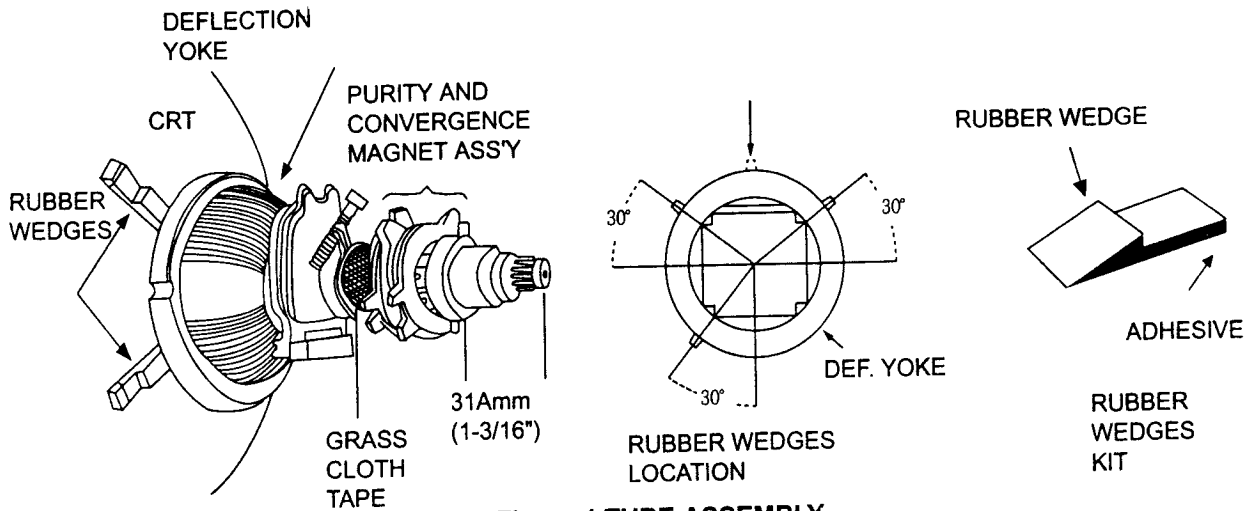

Figure 1. TUBE ASSEMBLY

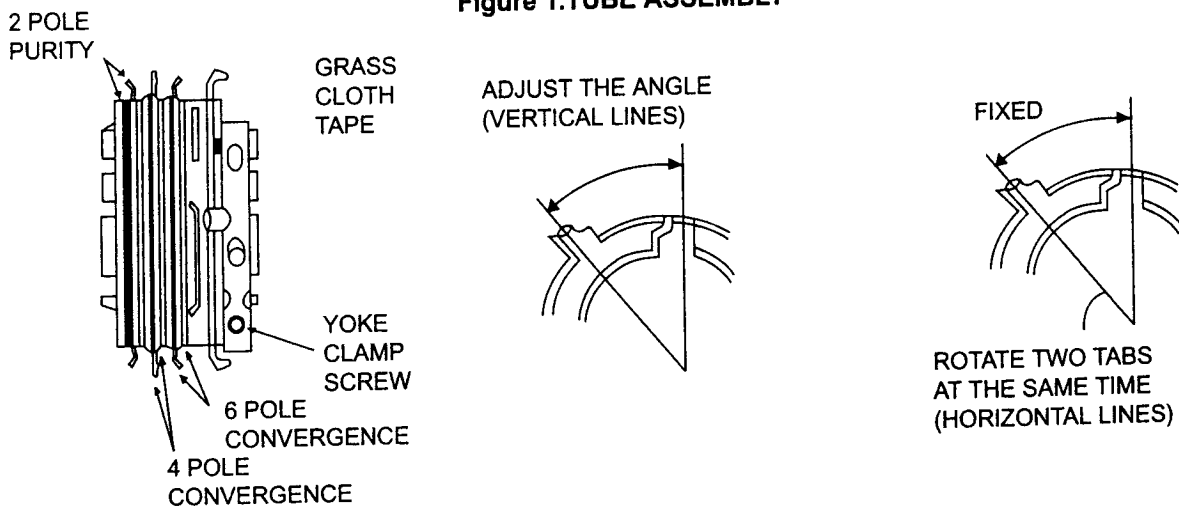
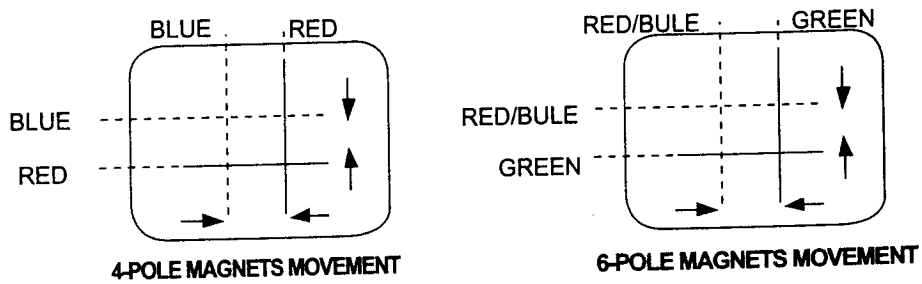
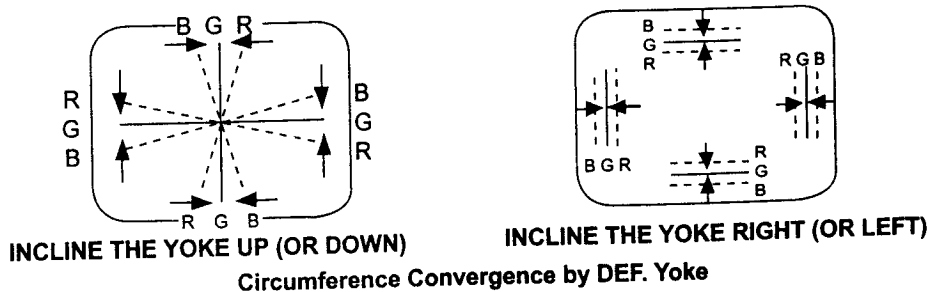

Figure 2. PURITY AND CONVERGENCE MAGNETS



Centre Convergence by Magnets



Circumference Convergence by DEF. Yoke

Figure 3. Dot Movement Pattern

## 7. TELETEXT SECTION

### 1. TTX BLOCK DIAGRAM(OPTION)

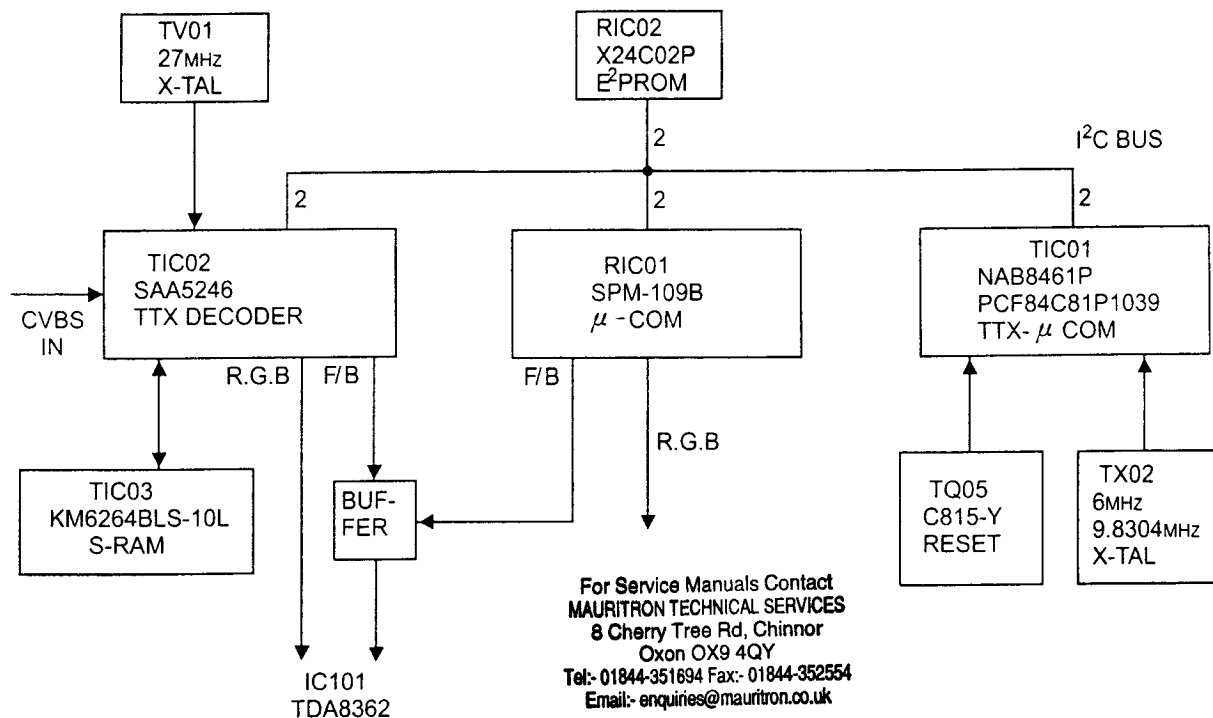

### 2. SEMICONDUCTOR SPECIFICATION

#### a. DESCRIPTION

The MAB8401 family of microcontrollers is fabricated in NMOS. The family consists of 5 devices:

- MAB8401 - 128 bytes RAM, external program memory, with 8-bit LED-driver(10mA), emulation of MAB/F8422/42 \* possible
- MAB/MAF8411 - 1K bytes ROM/64 bytes RAM plus 8-bit LED-driver
- MAB/MAF8421 - 2K bytes ROM/64 bytes RAM plus 8-bit LED-driver
- MAB/MAF8441 - 4K bytes ROM/128 bytes RAM plus 8-bit LED-driver
- MAB/MAF8461 - 6K bytes ROM/128 bytes RAM plus 8-bit LED-driver

Each version has 20 quasi-bidirectional I/O port lines, one serial I/O line, one single-level vectored interrupt, an 8-bit timer/event counter and on-board clock oscillator and clock circuits. Two 20-pin versions, MAB/F8422 and MAB/F8442 \* are also available.

This microcontroller family is designed to be an efficient controller as well as an arithmetic processor. The instruction set is based on that of the MAB8048. The microcontrollers have extensive bit handling abilities and facilities for both binary and BCD arithmetic.

For detailed information see the "8-bit single-chip microcontrollers user manual".

#### b. FEATURES

- 8-bit: CPU,ROM,RAM and I/O in a single 28-lead DIL package
- 1K,2K,4K, or 6K, ROM bytes plus a ROM-less version
- 64 or 128 RAM bytes
- 20 quasi-bidirectional I/O port lines
- Two testable inputs: one of which can be used to detect zero cross-over, the other is also the external interrupt input
- Single level vectored interrupts: external, timer/event counter, serial I/O
- Serial I/O that can be used in single or multi-master systems(serial I/O data via an existing port line and clock via a dedicated line)
- 8-bit programmable timer/event counter
- Internal oscillator, generated with inductor, crystal, ceramic resonator or external source
- Over 80 instructions (based on MAB8048) all of 1 or 2 cycles
- Single 5 V power supply ( $\pm 10\%$ )
- Operating temperature ranges:
 

0 to + 70°C	MAB84	× 1 family
-40 to + 85°C	MAF84	× 1 family only
-40 to + 110°C	MAF84A	× 1 family only

### C. PIN FUNCTION

Pin	Name	0	Function
1	P22	2	Not used
2	SDA	1	Serial data I <sup>2</sup> C-bus
3	SCL		Serial clock I <sup>2</sup> C-bus
4	P00	2	Link - select I <sup>2</sup> C/MIBUS control
5	P01	2	Power Down Imminent input
6	P02	3	PL output
7	P03	3	PON output
8	P04	3	PROC data output
9	P05	3	PROC clock output
10	P06	2	MIBUS data input
11	P07	3	DATA inhibit output
12	INT/TO	2	MIBUS DLEN, NAND, DLIM
13	T1		PL signal input
14	Vss		0V
15	XTAL 1		} Crystal oscillator connection (frequency =6MHz ± 500Hz)
16	XTAL 2		
17	RESET		Reset circuit
18	P10	2	Link - select FASTEXT/LIST mode at power-up
19	P11	2	Link - ENGLISH/EUROPEAN MIBUS & screen symbols
20	P12	2	Link - 2K8/8K8 static page RAM connected
21	P13	2	Link - enable use of NVRAM
22	P14	2	Link - enable PACKET 8/30 identification display
23	p15	2	Link - enable on-screen PROGRAM prompts
24	p16	2	Link - enable LVB controlled keys/status row
25	p17	2	Link - enable STATUS ROW used in NON-FASTEXT
26	p20	2	Link - select 128/256 byte NVRAM
27	p21	2	Not used
28	Vcc		5V(main) supply

#### ★ MAB8461P/W115 option (TTX)

Pin	0	Pin LOW	Pin HIGH
4	2	MIBUS command input	I <sup>2</sup> C command input
18	2	LIST mode at power-up	FASTEXT mode at power-up
19	2	European MIBUS & symbols	English MIBUS & symbols
20	2	2K8 static RAM connected	8K8 static RAM connected
21	2	No NVRAM connected	Enable use of NVRAM
22	2	Disable 8/30 display	Enable 8/30 display
23	2	Disable on-screen prompts	Enable on-screen prompts
24	2	Disable LCB decoding	Enable LCB decoding
25	2	Disable row 24 if no X/27	Enable row 24 if no X/27
26	2	256 × 8 NVRAM connected	258 × 8 NVRAM connected

#### PCF84C81/039 TTX-μ-Com

##### a. DESCRIPTION

An advanced CMOS process is used to manufacture the PCF84CXX family of microcontrollers. The family consists of the following devices:

- PCF84C00 - 256 × 8 RAM, external program memory
- PCF84C21 - 2 K × 8 ROM, 64 × 8 RAM
- PCF84C41 - 4 K × 8 ROM, 128 × 8 RAM
- PCF84C81 - 8 K × 8 ROM, 256 × 8 RAM

Each version has 20 quasi-bidirectional I/O port lines, a serial I/O interface, a single-level vectored interrupt structure, an 8-bit timer/event counter and on-chip clock oscillator and clock circuits.

Each member of this microcontroller family is an efficient controller as well as an arithmetic processor. The instruction set is similar to that of the MAB8048 and the

PCF84CXX family is pin-and instruction set compatible with the MAB8400 family. The microcontrollers have facilities for both binary and BCD arithmetic plus bit-handling capabilities. For detailed information see the user manual "Single-chip 8-bit microcontrollers".

#### b.FEATURES

- 8-bit CPU, ROM, RAM, I/O in a single 28-lead DIL or SO package
- 2K, 4K or 8K × 8 ROM; also a ROM-less version
- 64, 128 or 256 × 8 RAM
- 20 quasi-bidirectional I/O port lines
- Two test inputs: one of which is also the external interrupt input
- Single-level vectored interrupts: external, timer/event counter, serial I/O

- I<sup>2</sup>C hardware interface for serial data transfer on two lines (serial I/O data via an existing port line and clock via a dedicated line)
- 8-bit programmable timer/event counter
- Clock frequency range: 100 KHz to 10 MHz
- Over 80 instructions (similar to those of the MAB8048) all of 1 or 2 cycles
- Single supply voltage (2.5V to 5.5V)
- STOP and IDLE modes
- Power-on-reset circuit
- Operating temperature range: -40 to + 85 °C
- High current output on port 1: I<sub>OL</sub>=10 mA at V<sub>OL</sub>=1.2V(all versions except the PCF84C00)

#### c.PIN FUNCTION

Pin	Name	0	Function
1	P22	1	Link-Western/Eastern Europe
2	SDA		Serial data I <sup>2</sup> C-bus
3	SCL		Serial clock I <sup>2</sup> C-bus
4	P00	1	Link - select I <sup>2</sup> C/MIBUS control
5	P01	1	Power Down Imminent input
6	P02	1	PL output
7	P03	1	PON output
8	P04	1	PROC data output
9	P05	1	PROC clock input
10	P06	1	MIBUS data input
11	P07	1	DATA inhibit output
12	INT/TO		MIBUS DLEN, NAND, DLIM
13	T1		PL signal input
14	Vss		0C
15	XTAL 1		} Crystal oscillator connection(frequency =9.830 MHz ± 0.7%)
16	XTAL 2		
17	RESET		Reset circuit
18	P10	1	Link - select FASTEXT/LIST mode at power-up
19	P11	1	Link - ENGLISH/EUROPEAN MIBUS & screen symbols
20	P12	1	Link - 2K8/8K8 static page RAM connected
21	P13	1	Link - enable use of NVRAM
22	P14	1	Link - enable PACKET 8/30 identification display
23	p15	1	Link - enable on-screen PROGRAM prompts
24	p16	1	Link - enable LCB controlled keys/status row
25	p17	1	Link - enable STATUS ROW used in NON-FASTEXT
26	p20	1	Link - select 128/256 byte NVRAM
27	p21	1	Link - enable display of row 24
28	Vcc	1	5V(main) supply

For Service Manuals Contact  
**MAURITRON TECHNICAL SERVICES**  
 8 Cherry Tree Rd, Chinnor  
 Oxon OX9 4QY  
 Tel:- 01844-351694 Fax:- 01844-352554  
 Email:- enquiries@mauritron.co.uk

★ PCF84C81/039 option (TTX)

Pin	0	Pin LOW	Pin HIGH
1	1	E. Europe ECCT SAA5243/H	W. Europe ECCT SAA5243/E
4	1	MIBUS command input	I <sup>2</sup> C command input
18	1	LIST mode at power-up	FACSTEXT mode at power-up
19	1	European MIBUS & symbols	English MIBUS & symbols
20	1	2K8 static RAM connected	8K8 static RAM connected
21	1	No NVRAM connected	Enable use of NVRAM
22	1	Disable 8/30 display	Enable 8/30 display
23	1	Disable on-screen prompts	Enable on-screen prompts
24	1	Disable LCB decoding	Enable LCB decoding
25	1	Disable row 24 if no X/27	Enable row 24 if no X/27
26	1	256 × 8 NVRAM connected	256 × 8 NVRAM connected
27	1	Disable display of row 24	Enable display of row 24

a. TYPICAL FEATURES

- Low Power CMOS
  - Active Current Less Than 1 mA
  - Standby Current Less Than 50 μA
- internally Organized 256 × 8
- Self Timed Write Cycle
  - Typical Write Cycle Time of 5 ms
- 2 Wire Serial Interface
  - Bidirectional Data Transfer Protocol
- Four Byte Page Write Operation
  - Minimizes Total Write Time Per Byte
- High Reliability
  - Endurance: 100,000 Cycles Per Byte
  - Data Retention: 100 Years
- New hardwire-Write Control Function

b. DESCRIPTION

The X24C02 is a 2048 bit serial E<sup>2</sup>PROM, internally organized as one 256 × 8 page. The X24C02 features a serial interface and software protocol allowing operation on a simple two wire bus.

Xicor E<sup>2</sup>PROMs are designed and tested for applications requiring extended endurance. Inherent data retention is

greater than 100 years. Refer to RR-515 for details of data retention characteristics, and RR-520 for endurance cycling information for Xicor nonvolatile memories.

c. ABSOLUTE MAXIMUM RATINGS \*

Temperature Under Bias

X24C02 ..... -10°C to +85°C

X24C02I ..... -65°C to +135°C

Storage Temperature ..... -65°C to +150°C

Voltage on any Pin with

Respect to V<sub>SS</sub> ..... -1.0V to +7V

D.C. Output Current ..... 5 mA

Lead Temperature

(Soldering, 10 Seconds) ..... 300°C

d. D.C. OPERATING CHARACTERISTICS

X24C02 T<sub>A</sub> = 0°C to +70°C, V<sub>CC</sub> = 5V ± 10%, unless, otherwise specified.

X24C02I T<sub>A</sub> = -40°C to +85°C, V<sub>CC</sub> = 5V ± 10%, unless, otherwise specified.

V<sub>CC</sub> range for the X24C02 and X24C02I are defined in the Ordering information table.

Symbol	Parameter	Min.	Max.	Units	Test Conditions
I <sub>CC</sub>	Power Supply Current		1	mA	SCL = CMOS Levels @ 100 kHz, SDA = Open, all Other Inputs = GND or V <sub>CC</sub> - 0.3V
I <sub>SB</sub> <sup>(1)</sup>	Standby Current		50	μA	SCL = SDA = V <sub>IH</sub> All Other Inputs = V <sub>IL</sub> or V <sub>IH</sub>
I <sub>LI</sub>	Input Leakage Current		10	μA	V <sub>IN</sub> = GND to V <sub>CC</sub>
I <sub>LO</sub>	Output Leakage Current		10	μA	V <sub>OUT</sub> = GND to V <sub>CC</sub>
V <sub>IL</sub> <sup>(2)</sup>	Input Low Voltage	-1.0	V <sub>CC</sub> × 0.3	V	
V <sub>IH</sub> <sup>(2)</sup>	Input High Voltage	V <sub>CC</sub> × 0.7	V <sub>CC</sub> + 0.5	V	
V <sub>OL</sub>	Output Low Voltage		0.4	V	I <sub>OL</sub> = 3 mA

e.FUNCTIONAL DIAGRAM

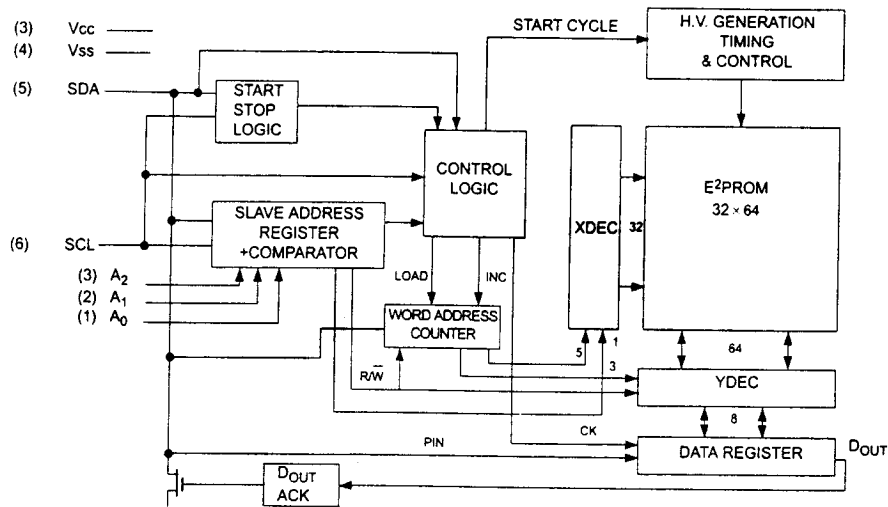

**KM6264 BCS-10L:S-RAM(MEMORY)**

a.GENERAL DESCRIPTION

The KM6264B/BL/BL-L is a 65,536-bit high-speed Static Random Access Memory organized as 8,192 words by 8 bit. The device is fabricated using Samsung's advanced CMOS process. The KM6264B/BL/BL-L has an output enable input for precise control of the data outputs. It also has chip select inputs for the minimum current power down mode. The KM6264B/BL/BL-L has been designed for high speed and low power applications. It is particularly well suited for battery back-up non-volatile memory applications.

b.FEATURES

- Fast Access Time: 70,100,120, ns (max.)
- Low Power Dissipation  
Standby (CMOS): 10µW (typ.) L-Version  
5µW (typ.) LL-Version
- Operating: 55mW/MHz (max.)
- Single 5V ± 10% Power Supply
- TTL compatible inputs and outputs
- Fully Static Operation  
- No clock or refresh required
- Three State Output
- Low Data Retention Voltage: 2V (min.)
- JEDEC Standard pin Configuration  
KM6264B/BL/BL-L: 28-pin DIP (600 mil)  
KM6264BS/BLS/BLS-L: 28-pin DIP (300 mil)  
KM6264BG/BLG/BLG-L: 28-pin SOP (330 mil)

c.PIN CONFIGURATION AND NAMES

A <sub>0</sub> -A <sub>12</sub>	Address inputs
WE	Write enable
CS <sub>1</sub> ,CS <sub>2</sub>	Chip select
OE	Output enable
I/O <sub>1</sub> -I/O <sub>8</sub>	Data input/Output
Vcc	+5V power supply
Vss	Ground

d.Recommended operating conditions (ta=0°C to 70°C)

\* Note: VIL(min)=-3.0V for ≤ 50ns pulse.

Parameter	Symbol	Min.	Typ.	Max.	Unit
Supply voltage	Vcc	4.5	5.0	5.5	V
Ground	Vss	0	0	0	V
Input high voltage	VIH	2.2	—	Vcc+0.3	V
Input low voltage	VIL	-0.3	—	0.8	V

For Service Manuals Contact  
**MAURITRON TECHNICAL SERVICES**  
 8 Cherry Tree Rd, Chinnor  
 Oxon OX9 4QY  
 Tel:- 01844-351694 Fax:- 01844-352554  
 Email:- enquiries@mauritron.co.uk

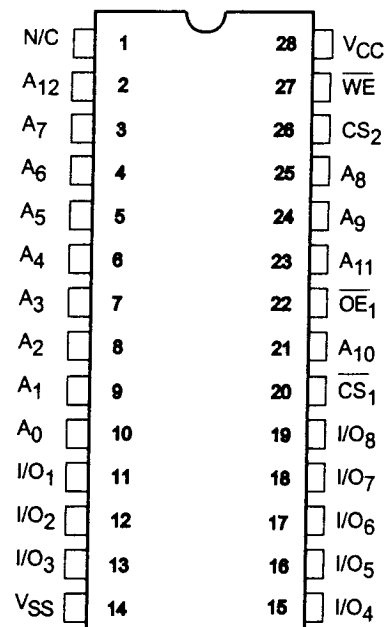

Pin configuration

e.FUNCTIONAL BLOCK DIAGRAM

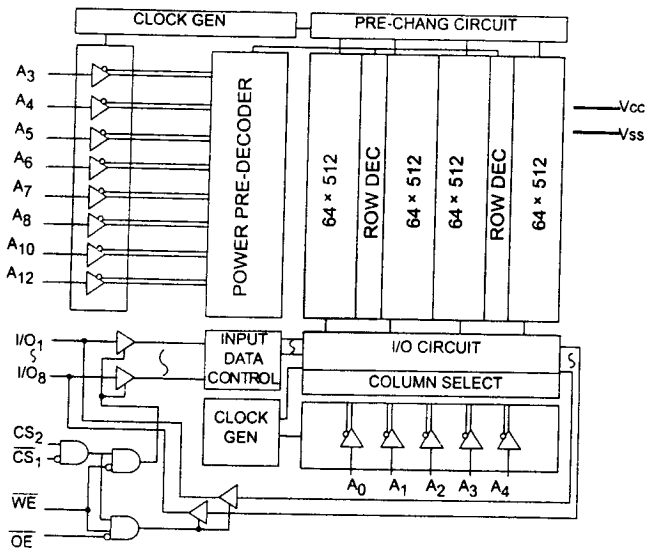

INTEGRATED VIP AND TELETEXT(IVT)

a.GENERAL DESCRIPTION

The integrated VIP and Teletext(IVT) is a teletext decoder (contained within a single chip package) for decoding 625-line based World System Teletext transmissions. The teletext decoder hardware is based on the Enhanced Computer Controlled Teletext (ECCT) device (SAA5243) with some additional features; existing ECCT software remains compatible. The Video Input Processor (VIP) section of the device uses new mixed analogue and digital designs for the Data Slicer and the Display Clock Phase Locked Loop functions. As a result the number of

c.PINNING DESCRIPTION

Pin	Name	Description
1	VDDD	+5V supply to the digital sections of the device.
2	OSCOU	27MHz crystal oscillator output.
3	OSCIN	27MHz crystal oscillator input.
4	OSCGND	Crystal oscillator ground, 0V.
5	VSSA	Analogue ground, 0V.
6	REF+	Positive reference voltage for the ADC. If necessary, the pin should be connected to analogue +5V via decoupling components.
7	BLANK	Video black level storage pin, connected to analogue ground via a 100nF capacitor.
8	CVBS	Composite video input pin. A positive-going 1V peak-to-peak input is required, connected via a 100nF capacitor.
9	Iref	Reference current input pin, connected to analogue ground via a 27kΩ resistor.
10	VDDA	+5V supply to the analogue sections of the device.
11	POL	STTV/LFB/FFB polarity select pin.
12	STTV/LFB	Sync to TV output pin/line flyback input pin, function controlled by an internal register bit.
13	VCR/FFB	PLL time constant switch/field flyback input pin, function control by an internal register bit.
14	VSSD	Connected to VSSD for normal operation.
15	R	Dot rate character output of the RED colour information.
16	G	Dot rate character output of the GREEN colour information.
17	B	Dot rate character output of the BLUE colour information.
18	RGBREF	DC voltage to define the output high level on the RGB pins.
19	BLAN	Dot rate fast blanking output. HIGH for text and LOW for picture.

external components is greatly reduced and no critical or adjustable components are required.

Features

- Complete teletext decoder in single 48-pin DIL package
- Single +5V power supply
- Digital Data Slicer and Display Clock Phase Locked Loop reduce peripheral components to a minimum
- Both video and scan related synchronization modes are supported
- 4/8 page acquisition system is software compatible with ECCT
- RGB interface to standard color decoder ICs, push pull output drive; requires only 2 external resistors
- Data capture performance comparable with SAA5231 (VIP2)
- Software compatibility with ECCT maintained
- Interfaces with 8K x 8-bit static RAM
- Optional storage of packet 24 in the display memory
- Packet 8/30/2 mapped to a different extension chapter as an aid for VCR programming applications

b.QUICK REFERENCE DATA

Parameter	Symbol	Min.	Typ.	Max.	Unit
Supply voltage	VDD	4.5	5	5.5	V
Supply current	I <sub>DD</sub>	—	60	120	mA
Sync amplitude	V <sub>syn</sub>	0.1	0.3	0.6	V
Video amplitude	V <sub>vid</sub>	0.7	1	1.4	V
Crystal frequency	f <sub>XTAL</sub>	—	27	—	MHz
Operating ambient temperature range	T <sub>amb</sub>	-20	—	+70	°C

Pin	Name	Description
20	$\overline{\text{COR}}$	Programmable output to provide contrast reduction of the TV picture for mixed text and picture displays or when viewing newsflash/subtitle pages. 25Hz output synchronized with the CVBS input's field sync pulses to produce a noninterlaced display by adjustment of the vertical deflection currents.
21	$\overline{\text{ODD/EVEN}}$	
22	Y	Dot rate character output of teletext foreground colour information. Open drain output.
23	SCL	Serial clock input for I <sup>2</sup> C-bus. It can still be driven HIGH during power-down of the device.
24	SDA	Serial data port for the I <sup>2</sup> C-bus. Open drain output. It can still be driven HIGH during power-down of the device.
25	VSSD	Digital ground, 0V.
26-33	D0-D7	Data lines for the page RAM.
34-46	A0-A12	Address lines for the page RAM.
47	$\overline{\text{OE}}$	Output enable to the page RAM.
48	$\overline{\text{WE}}$	Write enable to the page RAM.

d. IVT BLOCK DIAGRAM

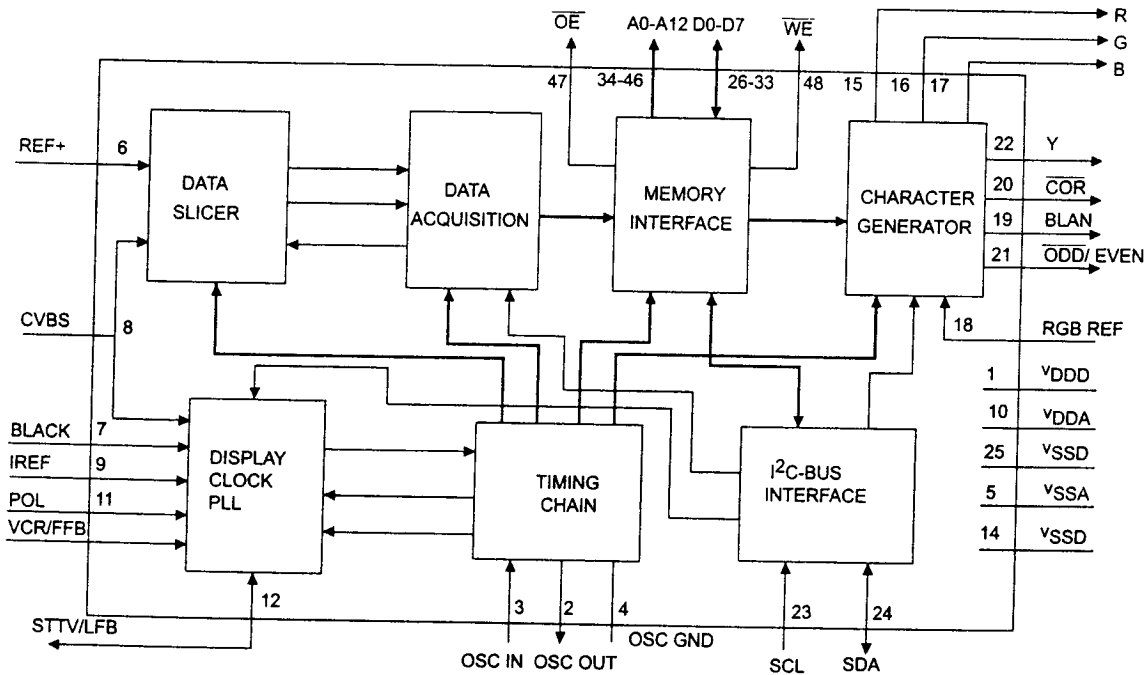

MEMO

.....

.....

.....

.....

.....

.....

.....

.....

.....

MEMO

.....

.....

.....

**For Service Manuals Contact**  
**MAURITRON TECHNICAL SERVICES**  
**8 Cherry Tree Rd, Chinnor**  
**Oxon OX9 4QY**  
**Tel: 01844-351694 Fax: 01844-352554**  
**Email: enquiries@mauritron.co.uk**

.....

.....

.....

.....



## 8. TROUBLESHOOTING CHARTS

NO POWER : Chart 1

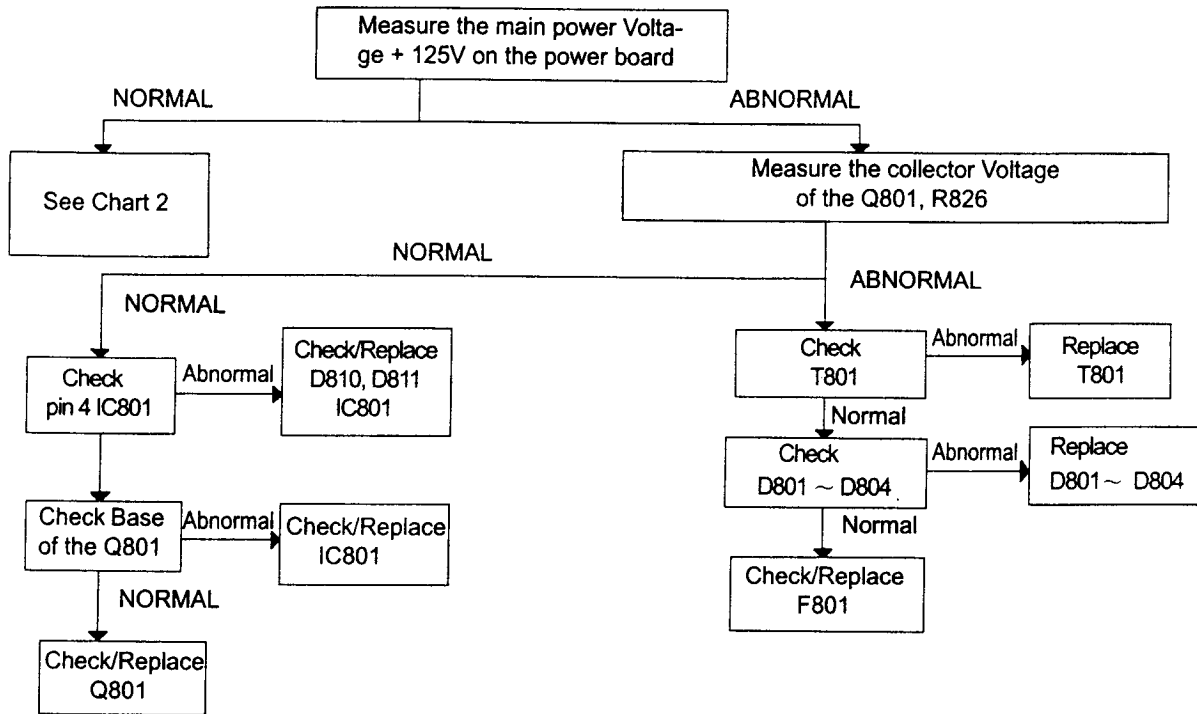

NO RASTER AND NO SOUND : Chart 2

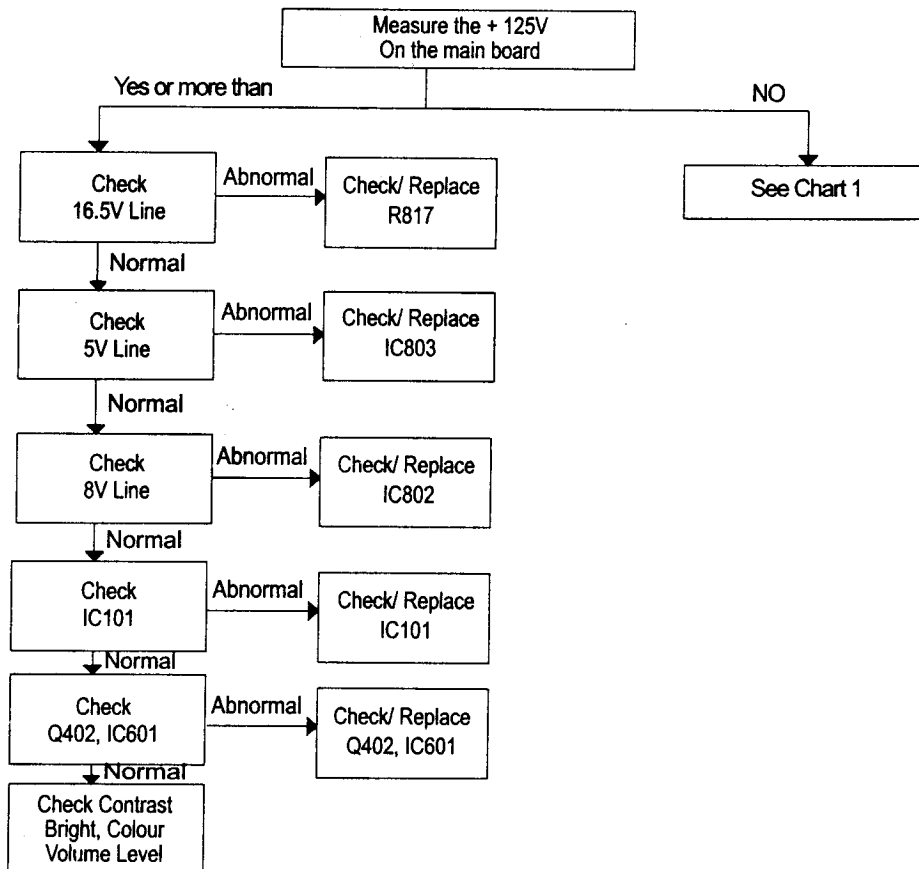

NO RASTER (SOUND OK) : Chart 3

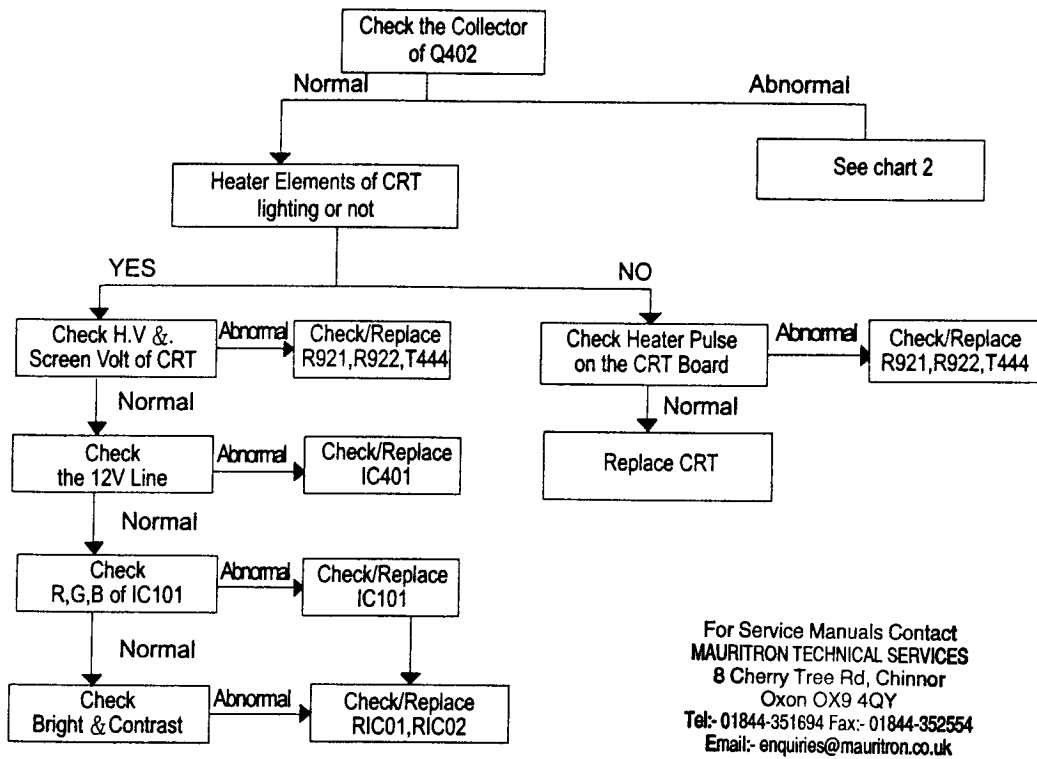

NO PICTURE (RASTER OK) : Chart 4

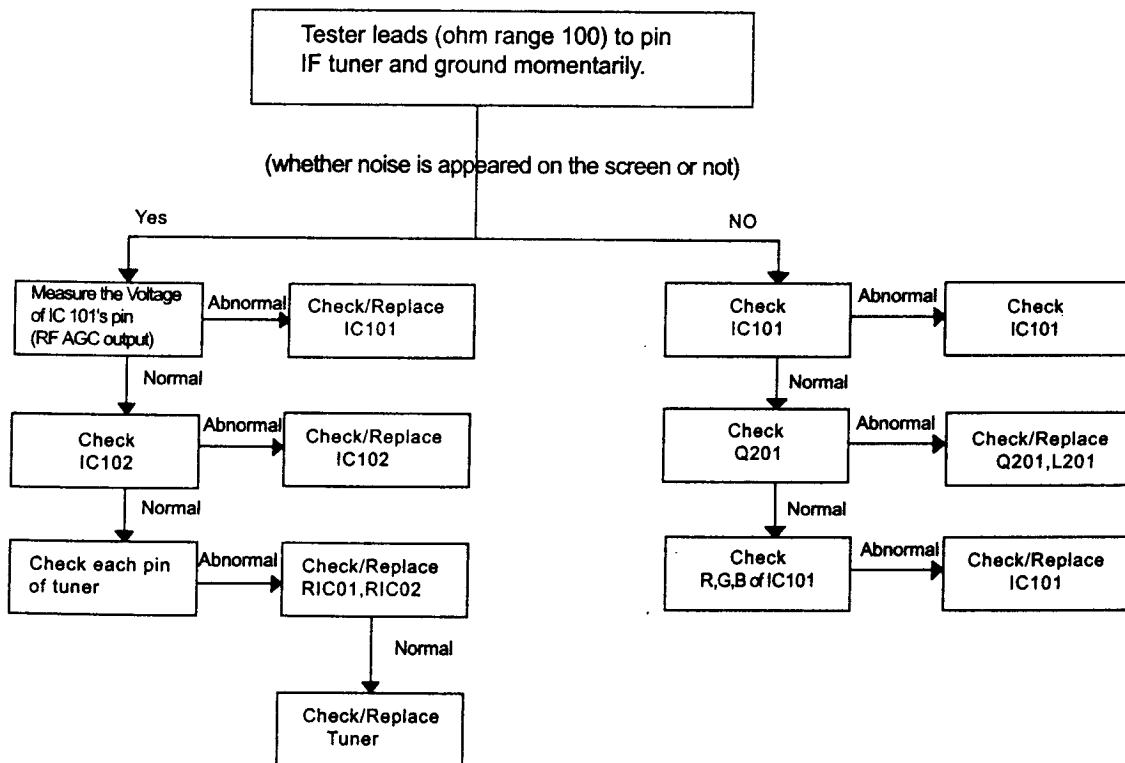

NO VERT SCAN ( One Horiz, LINE RASTER ) : Chart 5

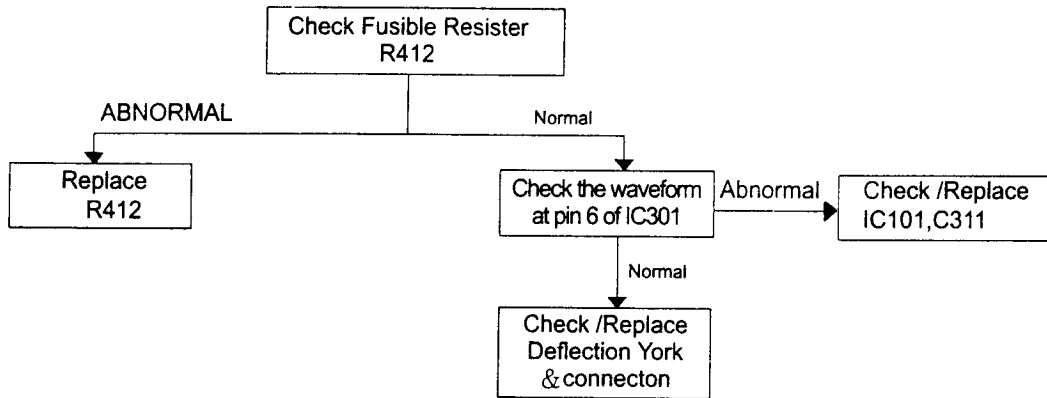

NO SOUND ( Picture OK ) : Chart 6

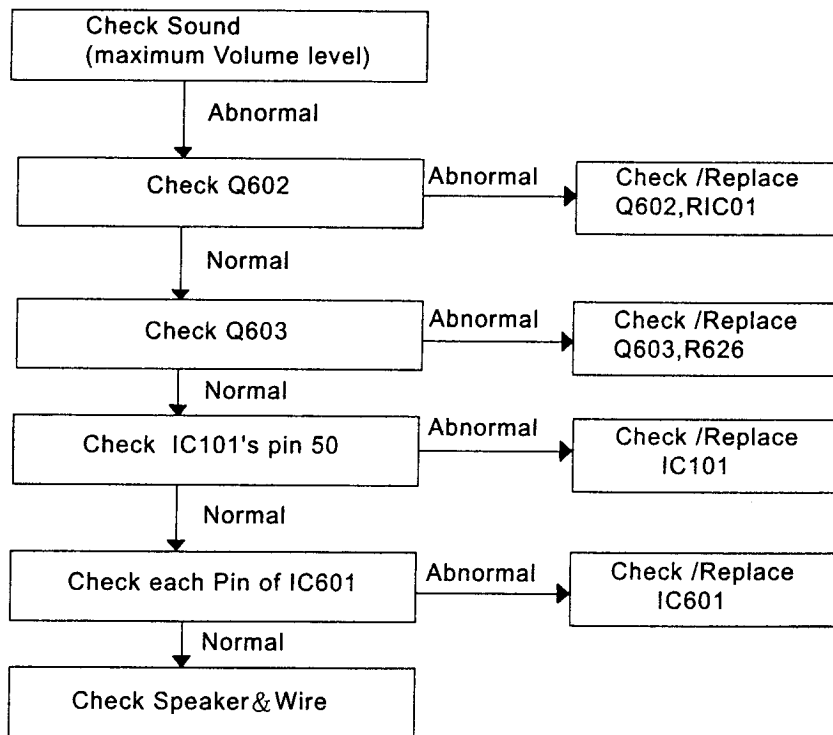

MEMO	.....
	.....
	.....
	.....

MEMO	.....
	.....
	.....
	.....



# 9. INSERTING FROM OF THE IMPORTANT PARTS

ELECTROLYTIC-  
CONDENSER

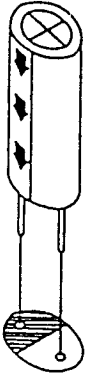

DIODE

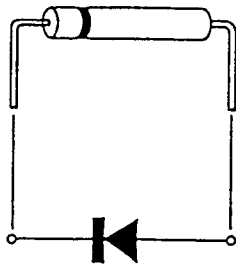

IC

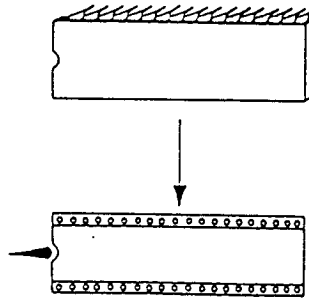

TDA4661 (Pin 16)  
TDA8362 (Pin 52)  
SPM-109(Pin 42)  
X24CO2P(Pin 8).  
TDA8395(Pin 16)

**TTX-OPTION**

KM6264BL(Pin 28)  
SAA5246P(Pin 48)  
MAB8461P(Pin 28)  
KS74HCTLS24IN(Pin 20)

TRANSISTOR

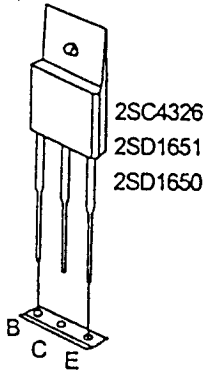

2SC4326  
2SD1651  
2SD1650

TRANSISTOR

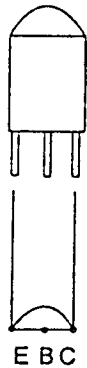

KSA815-Y  
KSA539-Y

IC

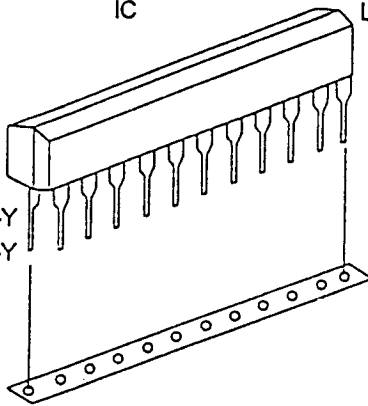

LA7910(9 Pin)

SAW-FILTER

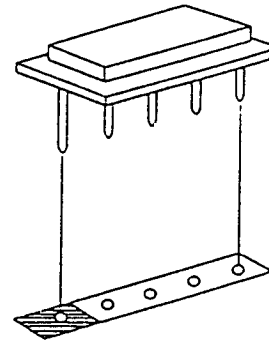

OFWG1956

IC

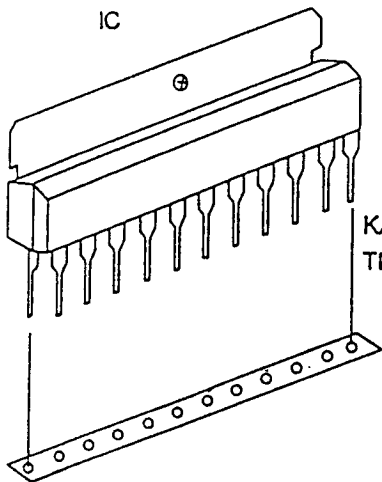

KA2131  
TDA1013A

TRANSISTOR

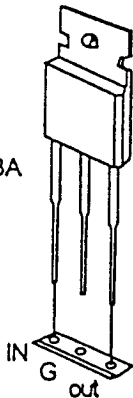

MC7812C  
MC7808C  
MC7805C

TRANSISTOR



2SC2068

IC

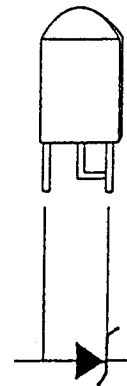

UPC574J  
or  
KA33V

# 10. CHASSIS REPLACEMENT PARTS LIST

ABBREVIATIONS : CC C-CERAMIC RC R-COMPOSITION  
 CE C-ELECTROLYTIC RD R-CARBON  
 CFS C-M, POLYESTER RF R-FUSIBLE  
 CK C-CERAMIC, HK RM R-METAL, FILM  
 CQ C-POLYPROPYLENE, POLYESTE RP R-CEMENT WIRE  
 CS C-TANTALIUM, SOLID RS R-METAL, OXIDE

NOTE : The items with "\*" are usually out of stock since they are seldom required for the routine service. There may be some anticipated delay when you order these items.

S.N.A. = Service Not Available , L/C = Local Purchase

The components identified by mark '\*\*' are critical for safety. Replace only with Supplier part number specified.

When indicating parts by location number, Please include the PWB names  
 ( PWB = Printed Writing Board )

Loc No	Supplier Parts No.	Specification	Loc No	Supplier Parts No.	Specification
A S S Y - P W B , M A I N			R306	31018-377-159	RD 1/2T 1.5R-J
*3X30-01720Y030 CI3352X/TSECX <S.N.A>			R307	31018-177-513	RD 1/8T 51K-J
PWB	33004-157-411	P68SG-M <S.N.A>	R308	31018-177-183	RD 1/8T 18K-J
RESISTORS			R309	31018-377-271	RD 1/2T 270-J
MR001	31018-377-122	RD 1/2T 1.2K-J	R310	31018-177-153	RD 1/8T 15K-J
MR002	31018-377-122	RD 1/2T 1.2K-J	R311	31018-177-224	RD 1/8T 220K-J
R100	31018-177-682	RD 1/8T 6.8K-J	R312	31018-177-223	RD 1/8T 22K-J
R106	31018-177-391	RD 1/8T 390-J	R313	31018-377-105	RD 1/2T 1M-J
R112	31018-177-682	RD 1/8T 6.8K-J	R401	31018-177-153	RD 1/8T 15K-J
R113	31018-177-333	RD 1/8T 33K-J	R402	31018-177-273	RD 1/8T 27K-J
R114	31018-177-104	RD 1/8T 100K-J	R404	31018-177-332	RD 1/8T 3.3K-J
R115	31018-177-104	RD 1/8T 100K-J	R407	31018-377-124	RD 1/2T 120K-J
R116	31018-177-561	RD 1/8T 560-J	R408	31018-177-101	RD 1/8T 100-J
R117	31018-177-562	RD 1/8T 5.6K-J	R410	31018-377-271	RD 1/2T 270-J
R122	31018-177-473	RD 1/8T 47K-J	R411	31018-377-680	RD 1/2T 68-J
R123	31018-177-473	RD 1/8T 47K-J	**R412	31059-002-010	RF 1/2P 1-J
R124	31018-177-104	RD 1/8T 100K-J	**R414	31059-427-151	RF 1P 150-J
R201	31018-177-102	RD 1/8T 1K-J	**R415	31049-101-350	RS 1P 1K-J
R202	31018-177-181	RD 1/8T 180-J	R416	31018-377-473	RD 1/2T 47K-J
R203	31018-177-131	RD 1/8T 130-J	R417	31018-377-563	RD 1/2T 56K-J
R204	31018-177-109	RD 1/8T 1-J	**R418	31059-002-010	RF 1/2P 1-J
R205	31018-177-102	RD 1/8T 1K-J	R420	31018-177-824	RD 1/8T 820K-J
R207	31018-177-622	RD 1/8T 6.2K-J	R500	31018-177-473	RD 1/8T 47K-J
R208	31018-177-472	RD 1/8T 4.7K-J	R501	31018-177-562	RD 1/8T 5.6K-J
**R209	31048-361-001	RM 1/2T 1K-G	R502	31018-177-103	RD 1/8T 10K-J
**R210	31049-375-194	RM 1/2T 190K-F	R503	31018-177-104	RD 1/8T 100K-J
R211	31018-177-750	RD 1/8T 75-J	R504	31018-177-561	RD 1/8T 560-J
R212	31018-177-750	RD 1/8T 75-J	R505	31018-177-101	RD 1/8T 100-J
R214	31018-177-470	RD 1/8T 47-J	R506	31018-177-101	RD 1/8T 100-J
R215	31018-177-273	RD 1/8T 27K-J	R507	31018-177-101	RD 1/8T 100-J
R216	31018-177-102	RD 1/8T 1K-J	R510	31018-177-750	RD 1/8T 75-J
R220	31018-177-181	RD 1/8T 180-J	R511	31018-177-750	RD 1/8T 75-J
R303	31018-177-331	RD 1/8T 330-J	R512	31018-177-750	RD 1/8T 75-J
R304	31018-377-681	RD 1/2T 680-J	R516	31018-177-103	RD 1/8T 10K-J
R305	31018-177-203	RD 1/8T 20K-J	R518	31018-177-470	RD 1/8T 47-J
			R519	31018-177-750	RD 1/8T 75-J
			R520	31018-177-154	RD 1/8T 150K-J
			R608	31018-177-562	RD 1/8T 5.6K-J
			R609	31018-177-562	RD 1/8T 5.6K-J

Loc No	Supplier Parts No.	Specification	Loc No	Supplier Parts No.	Specification
R610	31018-177-101	RD 1/8T 100-J	**R918	31046-567-183	RS 2T 18K-J(AUTO)
R614	31018-177-432	RD 1/8T 4.3K-J	**R919	31046-567-183	RS 2T 18K-J(AUTO)
R615	31018-177-203	RD 1/8T 20K-J	**R920	31046-567-183	RS 2T 18K-J(AUTO)
R616	31018-177-224	RD 1/8T 220K-J			
R617	31018-177-562	RD 1/8T 5.6K-J	**R921	31028-327-182	RC 1/2T 1.8K-J
R618	31018-377-479	RD 1/2T 4.7-J	**R922	31028-327-182	RC 1/2T 1.8K-J
R619	31018-177-122	RD 1/8T 1.2K-J	**R923	31028-327-182	RC 1/2T 1.8K-J
R622	31018-177-102	RD 1/8T 1K-J	**R924	31059-003-100	RF 1P 1-K
R623	31018-177-103	RD 1/8T 10K-J	**R925	31059-003-100	RF 1P 1-K
R624	31018-177-103	RD 1/8T 10K-J	RR01	31018-177-332	RD 1/8T 3.3K-J
R626	31018-177-562	RD 1/8T 5.6K-J	RR02	31018-177-103	RD 1/8T 10K-J
R637	31018-177-121	RD 1/8T 120-J	RR04	31018-177-153	RD 1/8T 15K-J
R640	31018-177-202	RD 1/8T 2K-J	RR05	31018-177-103	RD 1/8T 10K-J
R641	31018-377-470	RD 1/2T 47-J	RR06	31018-177-103	RD 1/8T 10K-J
R702	31018-177-203	RD 1/8T 20K-J	RR07	31018-177-472	RD 1/8T 4.7K-J
R703	31018-177-273	RD 1/8T 27K-J	RR08	31018-177-103	RD 1/8T 10K-J
R704	31018-177-103	RD 1/8T 10K-J	RR09	31018-177-202	RD 1/8T 2K-J
R705	31018-177-124	RD 1/8T 120K-J	RR10	31018-177-202	RD 1/8T 2K-J
R706	31018-177-202	RD 1/8T 2K-J	RR11	31018-177-162	RD 1/8T 1.6K-J
R707	31018-177-753	RD 1/8T 75K-J	RR12	31018-177-823	RD 1/8T 82K-J
R709	31018-177-202	RD 1/8T 2K-J	RR13	31018-177-203	RD 1/8T 20K-J
R710	31018-177-223	RD 1/8T 22K-J	RR14	31018-177-103	RD 1/8T 10K-J
**R802	31039-787-479	RW 10H 4.7-J	RR15	31018-177-752	RD 1/8T 7.5K-J
R803	31018-377-274	RD 1/2T 270K-J	RR16	31018-177-821	RD 1/8T 820-J
R804	31018-377-274	RD 1/2T 270K-J	RR17	31018-177-202	RD 1/8T 2K-J
**R805	31049-547-104	RS 2N 100K-J	RR18	31018-177-102	RD 1/8T 1K-J
**R807	31049-537-110	RS 2M 110-J	RR24	31018-177-102	RD 1/8T 1K-J
R808	31018-377-103	RD 1/2T 10K-J	RR25	31018-177-102	RD 1/8T 1K-J
**R811	31049-315-030	RS 2P 18K-J	RR26	31018-177-102	RD 1/8T 1K-J
**R812	31039-427-279	RW 3P 2.7-J	RR27	31018-177-102	RD 1/8T 1K-J
R814	31018-277-339	RD 1/4T 3.3-J	RR28	31018-177-102	RD 1/8T 1K-J
R815	31018-377-101	RD 1/2T 100-J	RR29	31018-177-103	RD 1/8T 10K-J
R816	31018-377-331	RD 1/2T 330-J	RR30	31018-177-102	RD 1/8T 1K-J
**R817	31059-002-130	RF 1/2P 0.47-K	RR37	31018-177-181	RD 1/8T 180-J
**R818	31049-527-399	RS 2P 3.9-J	RR38	31018-177-222	RD 1/8T 2.2K-J
**R819	31048-527-271	RS 2P 270-J	RR39	31018-177-223	RD 1/8T 22K-J
R820	31018-177-101	RD 1/8T 100-J	RR40	31018-177-181	RD 1/8T 180-J
**R822	31049-315-390	RS 2P 15K-J	RR42	31018-177-181	RD 1/8T 180-J
**R824	31049-315-101	RS 2P 100-J	RR43	31018-177-102	RD 1/8T 1K-J
**R826	31059-002-010	RF 1/2P 1-J	RR44	31018-177-102	RD 1/8T 1K-J
**R830	31028-328-475	RC 1/2T 4.7M-K	RR45	31018-177-101	RD 1/8T 100-J
**R831	31028-328-475	RC 1/2T 4.7M-K	RR46	31018-177-101	RD 1/8T 100-J
R901	31018-177-152	RD 1/8T 1.5K-J	RR47	31018-177-101	RD 1/8T 100-J
R902	31018-177-152	RD 1/8T 1.5K-J	RR48	31018-177-101	RD 1/8T 100-J
R903	31018-177-152	RD 1/8T 1.5K-J	RR50	31018-177-202	RD 1/8T 2K-J
R904	31018-177-751	RD 1/8T 750-J	RR51	31018-177-682	RD 1/8T 6.8K-J
R905	31018-177-751	RD 1/8T 750-J	RR52	31018-177-222	RD 1/8T 2.2K-J
R906	31018-177-751	RD 1/8T 750-J	RR53	31018-177-222	RD 1/8T 2.2K-J
R907	31018-177-102	RD 1/8T 1K-J	RR54	31018-177-222	RD 1/8T 2.2K-J
R908	31018-177-102	RD 1/8T 1K-J	RR55	31018-177-222	RD 1/8T 2.2K-J
R909	31018-177-102	RD 1/8T 1K-J	RR57	31018-177-221	RD 1/8T 220-J
R911	31018-177-102	RD 1/8T 1K-J	RR58	31018-177-470	RD 1/8T 47-J
R913	31018-177-151	RD 1/8T 150-J	RR59	31018-177-223	RD 1/8T 22K-J
R914	31018-177-561	RD 1/8T 560-J	RR61	31018-177-681	RD 1/8T 680-J
R915	31018-377-104	RD 1/2T 100K-J			
R916	31018-377-104	RD 1/2T 100K-J			
R917	31018-377-104	RD 1/2T 100K-J			
					VARIABLE RESISTORS
			VR101	31249-128-001	ENV-DJA A03 B14
			VR201	31249-128-008	ENV-DJA A03 B54

Loc No	Supplier Parts No.	Specification	Loc No	Supplier Parts No.	Specification
VR301	31249-128-004	ENV-DJA A03 B13	C420	31607-401-500	GE04W TAPG 16V 470M-M
VR303	31249-128-005	ENV-DJA A03 B53	C422	31417-106-090	CK45 TAPG B 500V 471-R
VR304	31249-128-003	ENV-DJA A03 B23	C423	31417-106-090	CK45 TAPG B 500V 471-R
VR401	31249-128-001	ENV-DJA A03 B14	C424	31417-106-090	CK45 TAPG B 500V 471-R
VR801	31249-128-003	ENV-DJA A03 B23	C425	31607-401-710	CED4W TAPG 25V 470M-M
VR901	31249-128-004	ENV-DJA A03 B13	C501	31407-057-180	GC45(T) GH 50V 180-J
VR902	31249-128-004	ENV-DJA A03 B13	C503	31507-127-016	ECQ B1 H 472J F3
VR903	31249-128-004	ENV-DJA A03 B13	C504	31507-127-012	EVQB1 H 104J-F3
VR904	31249-128-004	ENV-DJA A03 B13	C505	31507-127-012	EVQB1 H 104J-F3
VR905	31249-128-004	ENV-DJA A03 B13	C506	31507-127-012	EVQB1 H 104J-F3
VRR41	31249-128-005	ENV-DJA A03 B53	C507	31607-402-250	GE04W TAPG 50V 10M
CAPACITORS			C508	31607-402-250	GE04W TAPG 50V 10M
G102	31407-101-140	GC45(T) SL 50V 120-J	C509	31507-127-012	EVQB1 H 104J-F3
G104	31417-109-220	CK45 TAPG F 50V 223-Z	C510	31507-127-012	EVQB1 H 104J-F3
G109	31607-402-220	GE04W TAPG 50V 2.2M	C511	31507-127-012	EVQB1 H 104J-F3
G110	31507-127-012	EVQB1 H 104J-F3	C512	31507-127-008	ECQ B1 H 223J F3
G115	31507-127-012	EVQB1 H 104J-F3	C513	31607-401-460	GE04W TAPG 16V 47M
G116	31507-127-016	ECQ B1 H 472J F3	C515	31417-104-400	CK45 TAPG B 50V 102-R
G117	31607-402-220	GE04W TAPG 50V 2.2M	C516	31417-104-400	CK45 TAPG B 50V 102-R
G118	31607-402-250	GE04W TAPG 50V 10M	C521	31607-401-430	GE04W TAPG 25V 10M
G119	31607-401-500	GE04W TAPG 16V 470M-M	C550	31607-401-500	GE04W TAPG 16V 470M-M
G120	31607-902-250	GE04W TAPG 50V 0.22M	C609	31607-803-730	GE04W TAPG 50V 4.7M-NP
G122	31607-402-070	GE04W TAPG 35V 22M	C610	31607-803-730	GE04W TAPG 50V 4.7M-NP
G124	31607-902-250	GE04W TAPG 50V 0.22M	C612	31507-127-012	EVQB1 H 104J-F3
G125	31607-402-250	GE04W TAPG 50V 10M	C613	31507-127-006	ECQ B1 H 103J F3
G201	31507-127-010	ECQ B1H 473J F3	C615	31507-127-003	ECQ B1 H 332J F3
G202	31607-402-250	GE04W TAPG 50V 10M	C616	31607-402-210	GE04W TAPG 50V 1M
G203	31507-127-010	ECQ B1H 473J F3	C617	31607-401-770	GE04W TAPG 25V 2200M-M
G204	31507-127-012	EVQB1 H 104J-F3	C618	31607-803-280	GE04W TAPG 50V 1U-M(NP)
G205	31507-127-012	EVQB1 H 104J-F3	C620	31607-402-110	GE04W TAPG 35V 220M-M
G206	31607-401-500	GE04W TAPG 16V 470M-M	C621	31507-127-002	ECQ B1H 222J F3
G207	31507-127-012	EVQB1 H 104J-F3	C623	31607-402-250	GE04W TAPG 50V 10M
G208	31607-401-840	GE04W TAPG 10V 100M-M	C624	31507-127-015	ECQ B1 H 392J F3
**C209	31517-003-020	CFS922M TAPG 400V 104-J	C625	31407-105-260	CC45(T) GH 50V 470-J
G302	31507-127-003	ECQ B1 H 332J F3	C626	31407-105-660	CC45(T) GH 50V 101-J
G303	31507-127-011	ECQ B1H 683J F3	C627	31407-105-660	CC45(T) GH 50V 101-J
G304	31507-127-012	EVQB1 H 104J-F3	C628	31407-105-660	CC45(T) GH 50V 101-J
G305	31609-904-332	GE04W 25V 3300u	C630	31407-105-260	CC45(T) GH 50V 470-J
G306	31607-402-220	GE04W TAPG 50V 2.2M	C633	31507-127-016	ECQ B1 H 472J F3
G307	31607-402-290	GE04W TAPG 50V 100M-M	G701	31607-401-430	GE04W TAPG 25V 10M
G309	31507-127-014	ECQ B1 H 272J F3	G702	31607-401-430	GE04W TAPG 25V 10M
G310	31507-127-022	ECQ B1 H 513J F3	C800	31507-137-005	ECQ-B 1 222J F3
G311	31507-127-012	EVQB1 H 104J-F3	**C801	31569-204-190	250V 0.47M/RNB 1530
G312	31507-127-016	ECQ B1 H 472J F3	**C802	31569-204-190	250V 0.47M/RNB 1530
G401	31607-402-210	GE04W TAPG 50V 1M	C803	31467-502-220	CK45P TAPG E250V 222-Z
G402	31507-127-016	ECQ B1 H 472J F3	G804	31467-502-220	CK45P TAPG E250V 222-Z
G403	31417-109-220	CK45 TAPG F 50V 223-Z	C805	31467-502-220	CK45P TAPG E250V 222-Z
G404	31417-104-490	CK45 TAPG D 50V 272-M	C806	31467-502-220	CK45P TAPG E250V 222-Z
G405	31507-127-000	ECQ B1 H 102J F3	**C807	31519-010-000	CF922M 630V 0.022M-J
G409	31507-137-013	ECQ-B 1 103J F3	C808	31417-767-331	CK45(T) B2KV 331-K
**C411	31519-400-005	CFS 922M 1600V 0.0072-J	C810	31417-901-400	CK45(T) B2KV 561-K
C414	31607-402-710	GE04W TAPG 35V 1000M-M	C811	31417-901-400	CK45(T) B2KV 561-K
C416	31607-403-070	GE04W TAPG 100V 68M-M	C830	31469-105-010	CK45P E400V 332-M(T4KV)
**C417	31509-335-130	CQ922M 200V 0.36-J	C836	31417-109-140	CK45 TAPG F 50V 103-Z
C418	31607-403-450	GE04W TAPG 250V 1M	C837	31607-401-340	GE04W TAPG 10V 1000M-M
C419	31607-401-720	GE04W TAPG 25V 1000M-M	C838	31607-401-710	CED4W TAPG 25V 470M-M

For Service Manuals Contact  
**MAURITRON TECHNICAL SERVICES**  
8 Cherry Tree Rd, Chinnor  
Oxon OX9 4QY  
Tel: 01844-351694 Fax: 01844-352554  
Email: enquiries@mauritron.co.uk



Loc No	Supplier Parts No.	Specification
G851	31609-403-780	GE04W 400V 100M-M(LIG)
G852	31607-401-500	GE04W TAPG 16V 470M-M
G853	31607-403-250	GE04W TAPG 160V 100M-M
G854	31607-403-230	GE04W TAPG 160V 33M-M
G855	31607-401-720	GE04W TAPG 25V 1000M-M
G856	31607-401-720	GE04W TAPG 25V 1000M-M
G857	31607-402-250	GE04W TAPG 50V 10M
G858	31607-401-140	GE04W TAPG 6.3V 1000M-M
G859	31607-401-710	CE04W TAPG 25V 470M-M
G901	31407-105-120	CC45(T) CH 50V 121-J
G902	31407-105-120	CC45(T) CH 50V 121-J
G903	31407-105-120	CC45(T) CH 50V 121-J
G904	31417-104-250	CK45 TAPG B 50V 471-K
G905	31417-104-250	CK45 TAPG B 50V 471-K
G906	31417-104-250	CK45 TAPG B 50V 471-K
G907	31417-767-102	CK45(T) B2KV 102-K
G908	31607-403-450	GE04W TAPG 250V 1M
RC01	31507-127-001	EQ B1 H 152J F3
RC02	31507-127-025	EVQ-V1H 334J Z3
RC03	31507-127-025	EVQ-V1H 334J Z3
RC04	31607-402-250	GE04W TAPG 50V 10M
RC05	31607-402-250	GE04W TAPG 50V 10M
RC06	31607-402-250	GE04W TAPG 50V 10M
RC07	31607-402-250	GE04W TAPG 50V 10M
RC08	31507-127-002	EQ B1H 222J F3
RC09	31407-057-330	CC45(T) CH 50V 330-J
RC10	31607-401-450	GE04W TAPG 16V 33M
RC12	31607-401-470	GE04W TAPG 16V 100M VENT
RC13	31417-344-104	CK45 TAPG F 50V 104-Z
RC15	31607-401-470	GE04W TAPG 16V 100M VENT
RC16	31607-401-470	GE04W TAPG 16V 100M VENT
RC17	31407-105-700	CC45(T) CH 50V 151-J
RC21	31417-104-400	CK45 TAPG B 50V 102-R
RCT01	31497-009-340	EXF-FP4 331MDV(5P 331)
I C		
**DZ824	32119-101-360	KA 33V(TAPG)
IC101	32119-110-052	TDA8362
IC501	32119-110-089	TDA4661
**IC801	32119-910-017	SDH-209B
**IC803	32119-401-110	MC7805C ( AUTO )
RIC01	32109-110-072	SPM109B/PGA84C640P-051
RIC02	32109-210-023	X24C02P
RIC03	32119-110-061	KIA7033P(T)
TRANSISTORS		
**Q401	32137-301-560	KSC 2331-Y(TAPG)
**Q803	32137-301-560	KSC 2331-Y(TAPG)
**Q802	32137-301-560	KSC 2331-Y(TAPG)
RQ10	32137-301-720	KSC 815-Y(TAPG)
RQ05	32137-301-720	KSC 815-Y(TAPG)
Q705	32137-301-720	KSC 815-Y(TAPG)
RQ09	32137-301-720	KSC 815-Y(TAPG)
Q601	32137-301-720	KSC 815-Y(TAPG)
RQ11	32137-301-720	KSC 815-Y(TAPG)
RQ01	32137-301-720	KSC 815-Y(TAPG)
Q704	32137-301-720	KSC 815-Y(TAPG)

Loc No	Supplier Parts No.	Specification
Q201	32137-301-720	KSC 815-Y(TAPG)
Q202	32137-301-720	KSC 815-Y(TAPG)
Q703	32137-401-530	KSA 539-Y(TAPG)
Q602	32137-401-530	KSA 539-Y(TAPG)
Q905	32137-401-530	KSA 539-Y(TAPG)
RQ12	32137-401-530	KSA 539-Y(TAPG)
Q903	32139-410-006	RTG2068
Q902	32139-410-006	RTG2068
Q901	32139-410-006	RTG2068
DIODES		
D102	32167-406-480	1N4148 TAPG
D201	32167-201-070	1N4003 TAPG
D301	32167-406-480	1N4148 TAPG
D302	32167-201-140	KF105S
D401	32167-208-510	ERB 43-04 TAPG
D402	32167-201-140	KF105S
D403	32167-208-510	ERB 43-04 TAPG
D404	32167-201-070	1N4003 TAPG
D405	32167-201-070	1N4003 TAPG
D410	32167-406-480	1N4148 TAPG
D411	32167-406-480	1N4148 TAPG
D505	32167-406-480	1N4148 TAPG
D506	32167-406-480	1N4148 TAPG
D507	32167-406-480	1N4148 TAPG
D508	32167-406-480	1N4148 TAPG
D513	32167-406-480	1N4148 TAPG
D601	32167-406-480	1N4148 TAPG
D704	32167-406-480	1N4148 TAPG
D705	32167-406-480	1N4148 TAPG
D801	32167-201-180	M100J(TAPG)
D802	32167-201-180	M100J(TAPG)
D803	32167-201-180	M100J(TAPG)
D804	32167-201-180	M100J(TAPG)
D805	32169-301-670	RH-2F
D806	32167-207-120	1R5GU41(TAPG)
D807	32167-207-120	1R5GU41(TAPG)
D808	32167-406-480	1N4148 TAPG
D809	32167-406-480	1N4148 TAPG
D810	32167-406-480	1N4148 TAPG
D811	32167-406-480	1N4148 TAPG
DZ501	32167-406-080	MTZ 5.1B
DZ825	32167-441-009	MTZ7.5C
RD01	32167-406-480	1N4148 TAPG
RD03	32167-406-480	1N4148 TAPG
RD04	32167-406-480	1N4148 TAPG
RD06	32167-406-480	1N4148 TAPG
RD08	32167-406-480	1N4148 TAPG
RD09	32167-406-480	1N4148 TAPG
RD10	32167-406-480	1N4148 TAPG
RD11	32167-406-480	1N4148 TAPG
RD14	32167-101-130	1K34A (TAPG)
RDZ01	32167-401-800	EQA02-06A/MTZ5.6B(TAPG)
RDZ02	32167-401-800	EQA02-06A/MTZ5.6B(TAPG)
RDZ03	32167-401-800	EQA02-06A/MTZ5.6B(TAPG)
RDZ04	32167-401-800	EQA02-06A/MTZ5.6B(TAPG)
RDZ05	32167-401-800	EQA02-06A/MTZ5.6B(TAPG)

Loc No	Supplier Parts No.	Specification	Loc No	Supplier Parts No.	Specification
		POSISTOR			MISCELLANEOUS
**P80J	32189-609-390	2C18R	CN201	33345-108-310	67094-003(SEP)
		MODULE REMOCON	CN202	33347-114-820	YW025-04(AUTO,NO TUBE)
**PR01	32199-411-002	SR-5CP	CN44	33124-205-007	4P 6-12.5-14MM
		LED	CN601	33345-108-310	67094-003(SEP)
**LD01	32309-110-230	DS2 (DL-ILR)/SL-5R	CN602	33058-302-016	B3XB3/F/400
		COILS	CN801	33124-205-003	2P 10MM
D-COIL	32479-029-100	9.2RT70L 940(DOU)	CN802	33124-205-003	2P 10MM
L102	32427-904-918	AL02-1R0K	CN901	33058-332-016	B6XB6/F/400
L103	32427-904-922	AL02-5R6K	CN902	33058-302-016	B3XB3/F/400
L201	32427-805-330	5.6UH-M	CN901	33058-312-012	B4XB4/F/300
L403	32429-833-020	6.8MH-K	EJ01	33333-510-120	HSJ0807-01-010
L404	32449-712-010	R-10/195UH	F801	33167-001-001	PFC 5000-0202
L503	32427-904-922	AL02-5R6K	L400	34047-019-060	3.5X6X1.0
L601	32427-805-450	12UH-K TAPC	L804	34047-019-060	3.5X6X1.0
L801	32429-633-090	39MHX2(U)	L807	34047-019-060	3.5X6X1.0
L803	32429-226-080	1UH-K	SGJ01	33136-103-030	HXC-1510-01-300A(R)
L805	32429-014-070	100UH-K	SW101	33609-101-025	KPT 2104-21
L824	32429-039-170	100UH (1A)	SW102	33598-001-001	JTR-1104
L901	32429-823-010	330UH-K	SW103	33598-001-002	JTR-1105
LW01	32449-412-650	180UH/480UH	SW801	33529-402-006	ESB-99835V/ESB-99832V
RL01	32427-904-924	AL02-100K(10UH)			ASSY-H/S VERT(SOUND)
RL02	32427-904-924	AL02-100K(10UH)			*3H82-00070Y000 35684-116-210,TDA1013A
RL03	32427-904-924	AL02-100K(10UH)	**IC602	32119-201-070	TDA1013A/N4
RL04	32427-904-924	AL02-100K(10UH)	H/SINK	35684-116-210	SPG-1 T1.0 FTZ
		TRANS	SCREW	37158-230-061	2S-3X6 FE FZY
T101	32717-513-800	38.9MHZ(S-60)			ASSY-H/S VERT(HORI)
**T401	32849-070-002	7.3MH/105UH			*3H82-00170Y000 14"2SD1650
**T801	32899-002-450	P:90-260,S:125/18V(ER42)	**Q402	32159-210-002	2SD1650 YD
		TRANS FLYBACK	H/SINK	35684-118-110	SPG-1 T1.0 FTZ
**T444	32859-152-510	FCM-2014FL	SCREW	37158-230-101	2S-3X10 FE FZY
		GRT-SOCKET	WASHE	37334-105-910	SPG-1 T1.0 FZY-1
**V999A	33359-063-610	HF-22.5A			ASSY-H/S VERT
		TUNER			*3H82-00170Y003 35684-118-110 KA2131
**TU001	34519-700-020	TECC2985VA14B	IC301	32119-102-300	KA 2131
		FILTERS	H/SINK	35684-118-110	SPG-1 T1.0 FTZ
Z101	34529-700-012	TSF5321	HOLD/W	36604-134-510	NYLON 66 VO NTR
Z202	34527-460-008	TPS6.0MBTF21	SCREW	37148-530-081	2S-3X8 FE FZY
Z602	34527-460-007	SFE6.0MBTF21	SCREW	37158-230-061	2S-3X6 FE FZY
		CRYSTALS			ASSY-H/S POWER
RX01	34539-001-000	10MHZ			*3H83-00380Y000 2SC4236,35684-121-710
X501	34539-011-010	HC-49/U 4.433619MHZ	**Q801	32159-210-007	2SC4236
		FUSE	H/SINK	35684-121-710	A1050S-H14 T2.0(2SC4236)
**F801	34709-084-730	FST 250V 3.15A 20MM	SCREW	37158-230-101	2S-3X10 FE FZY
					ASSY-H/S POWER
					*3H84-00020Y000 MC7812,CKD
			**IC402	32119-901-110	MC7812C ( AUTO )
			H/SINK	35684-118-330	A6063 EXTR BLK H30
			SCREW	37158-230-061	2S-3X6 FE FZY

Loc No	Supplier Parts No.	Specification	Loc No	Supplier Parts No.	Specification
		ASSY-H/S TR			
		*3H84-00020Y007 35684-118-330,MC7808C			
**IG802	32119-401-304	MC7808C(AUTO)			
H/SINK	35684-118-330	A6063 EXTR BLK H30			
SCREW	37158-230-061	2S-3X6 FE FZY			
		A S S Y - T R A N S M I T T E R			
		*3F14-00032-140 TM32,RM109,29,E,SS			
		A S S Y - H O L D E R , S P K			
		*3H93-53352Y020 CB3352X,			
LEAD/C	33058-003-012	S3ä2ü/F/300			
SPK	34209-200-020	O5F14BRA,8R,3W			
HOLD/S	36601-238D820	PS VO BLK #066 3352			
HOLD/S	36601-238-820	HIPS VO BLK #066			
GRILL	37712-117-410	SPC-1 TO.7 #066			
		A S S Y - P O W E R , C O R D			
POW/C	33054-801-114	GTBS-2F/7.5F+BLK-HOU			
HOLD/C	36603-111-310	P.P VO BLK (NEW)			
		A S S Y - C R T			
DY	32439-400-003	DSE-1422HL(1)			
CY	34099-027-010	JH-225			
SP-DY	36814-101-911	NEOPRENE VO BLK			
		A S S Y - A C C E S S O R Y			
TRAN/M	32759-113-010	R300-R75,MATCH W/BALUN			
ROD/A	34509-220-020	N/UL 620MM			
CARD/W	38124-132-610	WHT PAPER 220(S) SEUK			
SVC/N	38134-379-010	ART PAPER 100			
I/B	38134-425-110	ART PAPER 120 P68SC			
PE-BAG	38653-108-191	HDPE TO.015 230X400			

For Service Manuals Contact  
**MAURITRON TECHNICAL SERVICES**  
8 Cherry Tree Rd, Chinnor  
Oxon OX9 4QY  
Tel:- 01844-351694 Fax:- 01844-352554  
Email:- enquiries@mauritron.co.uk

# 11. EXPLODED-VIEW

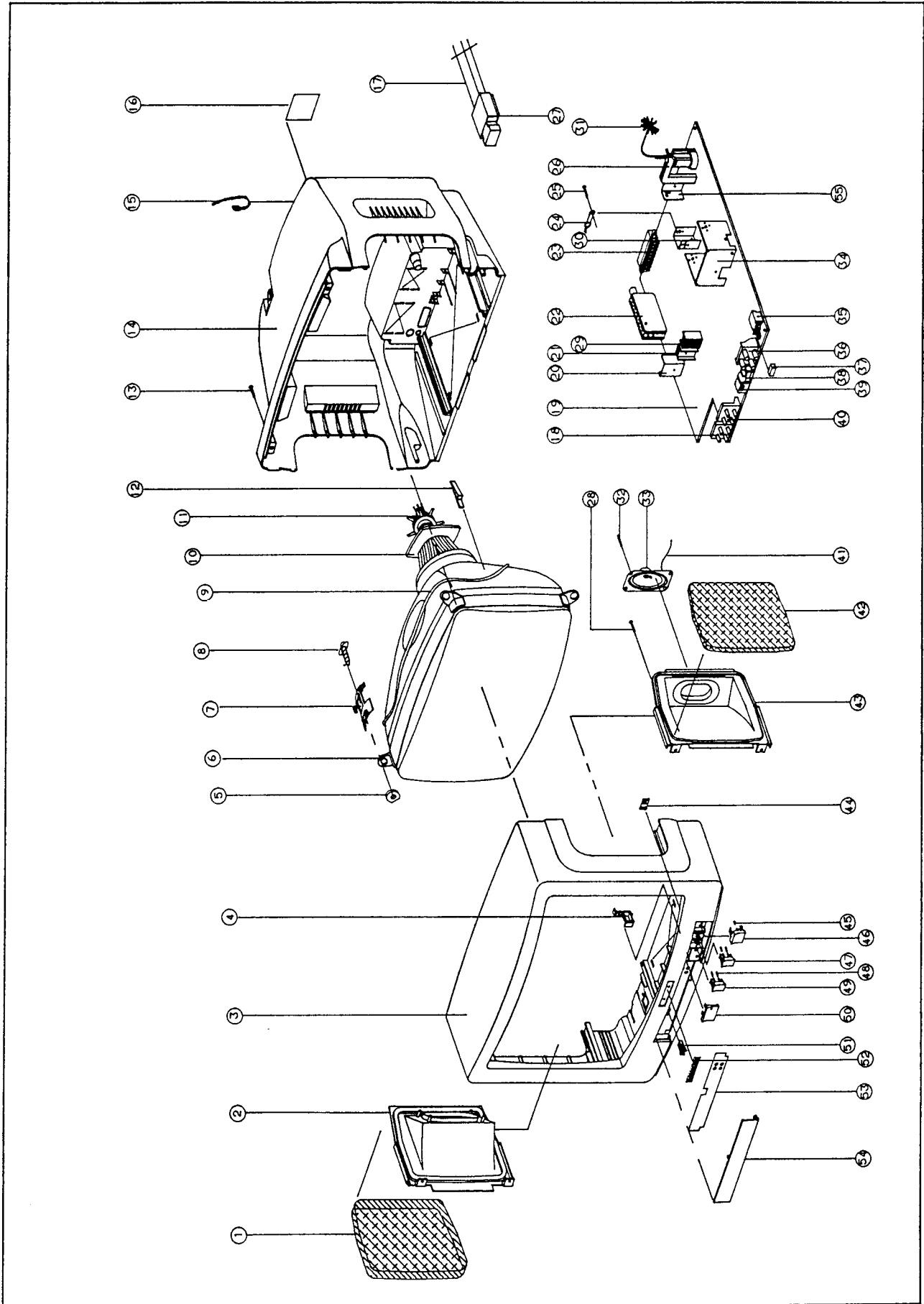

C13352X/TSECX

The items with "\*" are usually out of stock since they are seldom required for the routine service. There may be some anticipated delay when you order these items.  
 \*\*\* S.N.A = SERVICE NOT AVAILABLE. \*\*\*

NO	CODE NO	DESCRIPTION	SPECIFICATION	QTY
1	37712-117-410	GRILLE-WOOFER,L	SPC-1 T0.5 4R #066	1
2	36601-238-820	HOLDER-SPEAKER	HIPS VO BLK	1
3	*3Y90-33520-060	ASSY-CABINET,FRONT	HIPS BLK #066	1
4	36001-665-010	CABINET-FRONT	HIPS HB BLK #066	1
5	36023-118-810	STOPPER-PCB	HIPS HB NTR	1
6	37333-101-020	WASHER-GUM,CRT	NATURAL RUBBER	4
7	LOCAL-PURCHASE	CRT-COLOR		1
8	36635-001-910	CLAMPER-D,COIL	NYLON 6.6	2
9	37124-100-810	SCREW-CRT	5X30 RH+W/S AUTO	4
10	33479-029-100	COIL-DEGAUSSING	9.2RT70L	1
11	32439-400-003	DEFL-YOKE	DSE 1442 HL	1
12	34099-027-010	MAGNET-CONVERGENCE	JH-225	1
13	36814-101-911	SPACER-DY	NEOPRENE V0 BLK	1
14	37148-540-152	SCREW-TAP,RH	2S-4X15 FE FZW	6
15	36001-666-020	CABINET-BACK	HIPS V0 BLK	1
16	36633-101-610	CLAMPER-CORD	P.E HB BLK	1
17	38112-000-000	LABEL-RATTING	TETRONE PAPER	1
18	33054-801-114	POWER-CORD	KKD-419C KLCE-2F	1
19	33598-001-002	SWITCH-RUBBER	JTR-1105	1
20	*3X30-01720Y030	ASSY-PWB MAIN <S.N.A.>	C13352X/TSECX	1
21	33004-157-411	PWB-MAIN <S.N.A.>	330X245X1.6T	1
22	*3H82-00070Y000	ASSY-H/S,VERT(SOUND)	TDA1013A	1
23	*3H84-00020Y000	ASSY-H/S,TR	MC7812C	1
24	34519-700-020	TUNER	TECC-2985VA14B	1
25	33136-103-030	RECEPTACLE-PERI	HXC-1510-01-300A(R)	1
26	36604-134-510	HOLDER-WIRE	NYLON 66 VO NTR	1
27	37158-530-081	SCREW-TAP,RH	2S-3X8 FE FZY	1
28	32859-152-510	TRANS-FLYBACK	FCM-2014FL	1
29	36603-111-310	HOLDER-CORD	P.P VO BLK(NEW)	1
30	37148-540-152	SCREW-TAP,RH	2S-4X15 FE FZW	1
31	*3H84-00020Y007	ASSY-H/S,TR	MC7808C	1
32	*3H82-00170Y003	ASSY-H/S,VERT	KA2131	1
33	36633-101-910	CLAMPER-FBT,C	ABS VO GRY	1
34	37148-530-101	SCREW-TAP,RH	2S-3X12 FE FZY	1

NO	CODE NO	DESCRIPTION	SPECIFICATION	QTY
33	34209-200-020	SPEAKER-GENERAL	05F 14BRA 8R 3W	2
34	*3H83-00380Y000	ASSY-H/S,POWER	2SC 4236	1
35	33529-402-006	SWITCH-PUSH,POWER	ESB-99835V/ESB-99832V	1
36	33609-101-025	SWITCH-TACT	KPT-2104-21	1
37	37624-621-510	KNOB-SUB,MASTER	ABS HB BLK	1
38	32309-110-230	LED	DS2/SL-5R	1
39	32196-411-002	REMOCON-MODULE	SR-5CP(R)	1
40	33598-001-001	SWITCH-RUBBER	JTR-1104	1
41	33058-003-012	LEAD-CONNECTOR,ASSY	S3(2)/F/300	1
42	37712-117-410	GRILLE-SPEAKER,R	SPC-1 T0.5 4R #066	1
43	36601-238-820	HOLDER-SPEAKER	HIPS VO BLK #066	1
44	38013-116-710	INDICATOR-LED	ACRYL CLEAR	1
45	36674-139-810	SPRING-COIL	SUS P10.5	4
46	37623-158-310	KNOB-POWER,MASTER	ABS HB BLK #066	1
47	37623-158-530	KNOB-CHANNEL	ABS HB BLK	1
48	36674-137-820	SPRING-COIL	SUS P10.5	4
49	37623-158-430	KNOB-VOLUME	ABS HB BLK	1
50	37653-125-550	WINDOW REMOTE	PC GE LEXAN	1
51	36698-100-110	CATCH-PUSH,DOOR	KIFUCO LA701	1
52	38024-178-010	BADGE-BRAND	AL-FORGING	1
53	38093-121-110	PVC-CONTROL	PVC SHEET T0.3 BLK	1
54	37642-140-050	DOOR-CONTROL	HIPS HB BLK #066	1
55	*3H82-00170Y000	ASSY-H/S,VERT(HORT)	14" 2SD1650	1

For Service Manuals Contact  
**MAURITRON TECHNICAL SERVICES**  
 8 Cherry Tree Rd, Chinnor  
 Oxon OX9 4QY  
 Tel: 01844-351694 Fax: 01844-352554  
 Email: enquiries@mauritron.co.uk

# MEMO

A large rectangular area with a solid border and horizontal dotted lines, intended for writing a memo.

For Service Manuals Contact  
MAURITRON TECHNICAL SERVICES  
8 Cherry Tree Rd, Chinnor  
Oxon OX9 4QY  
Tel: 01844-351694 Fax: 01844-352554  
Email: enquiries@mauritron.co.uk







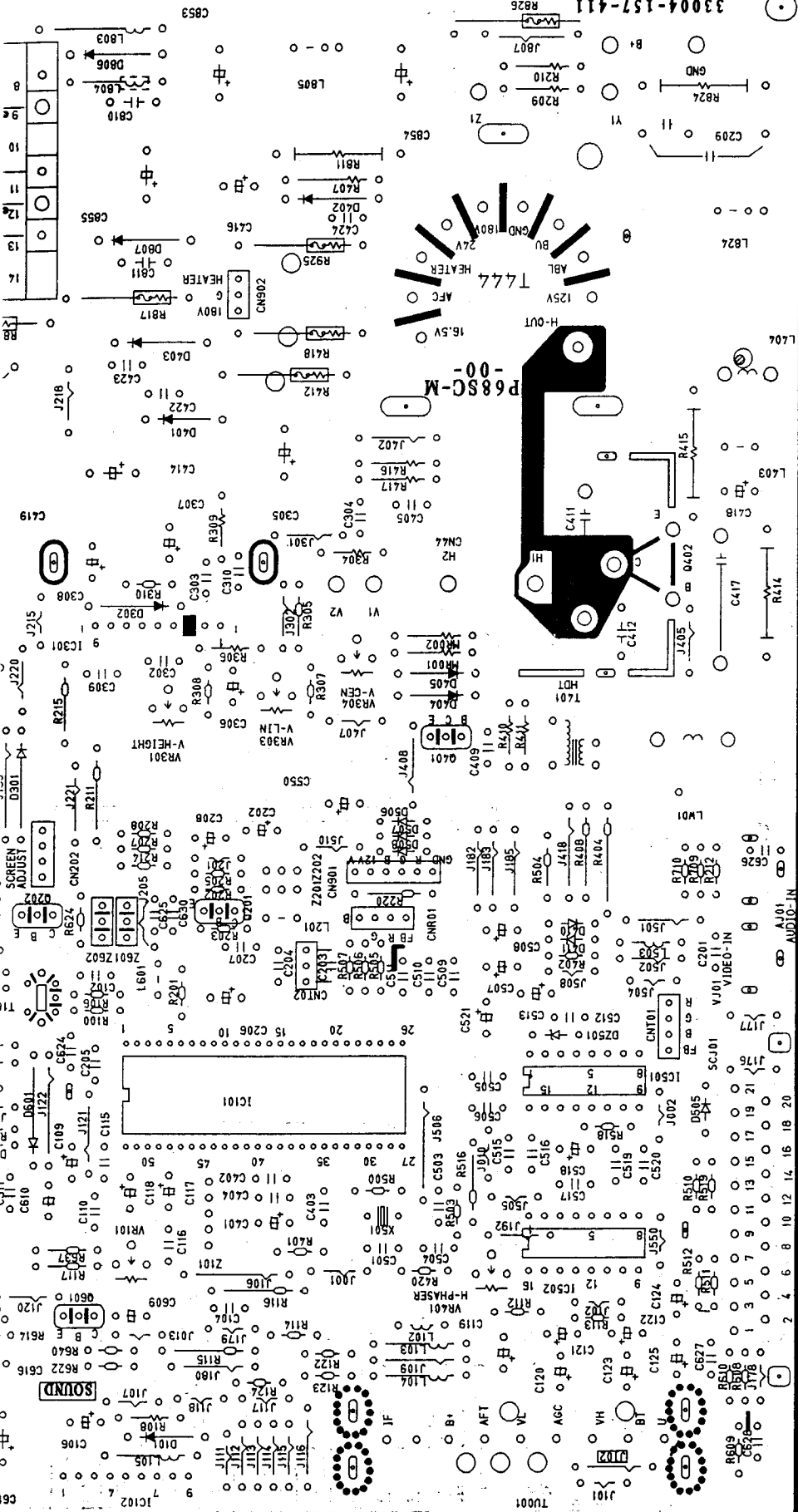

# SCHEMATIC DIAGRAM

CHASSIS: P68SC (N), (M), (H)

MODEL: CK(B. X. I)505 I X (T)

BOARD NAME: MAIN

SYSTEM: PAL/SECAM-B. G & D. K (PAL-I)

For Service Manuals Contact  
**MAURITRON TECHNICAL SERVICES**  
 8 Cherry Tree Rd, Chinnor  
 Oxon OX9 4QY  
 Tel: 01844-351894 Fax: 01844-352554  
 Email: enquiries@mauritron.co.uk

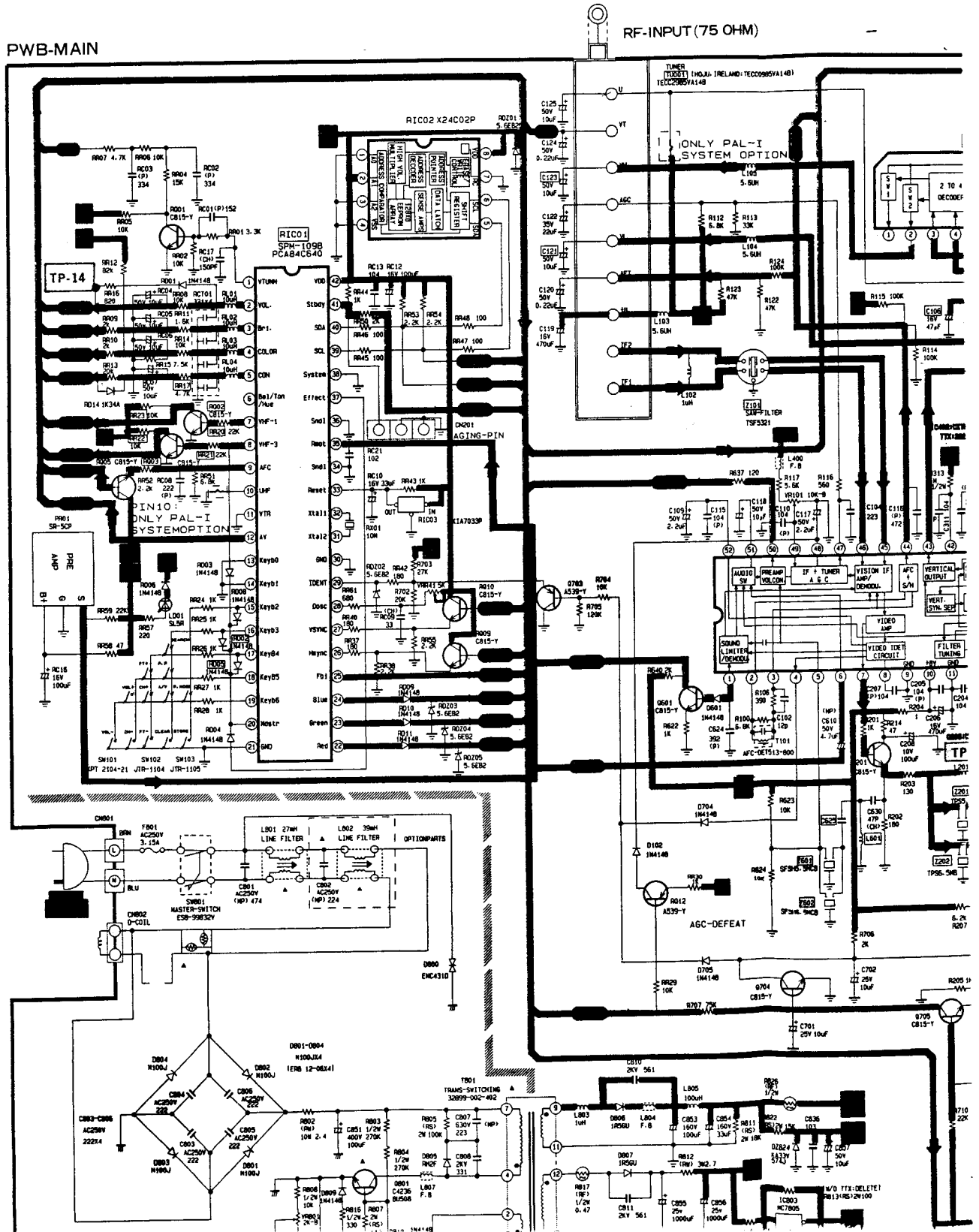

For Service Manuals Contact  
**MAURITRON TECHNICAL SERVICES**  
 8 Cherry Tree Rd, Chinnor  
 Oxon OX9 4QY  
 Tel: 01844-351694 Fax: 01844-352554  
 Email: enquiries@mauritron.co.uk

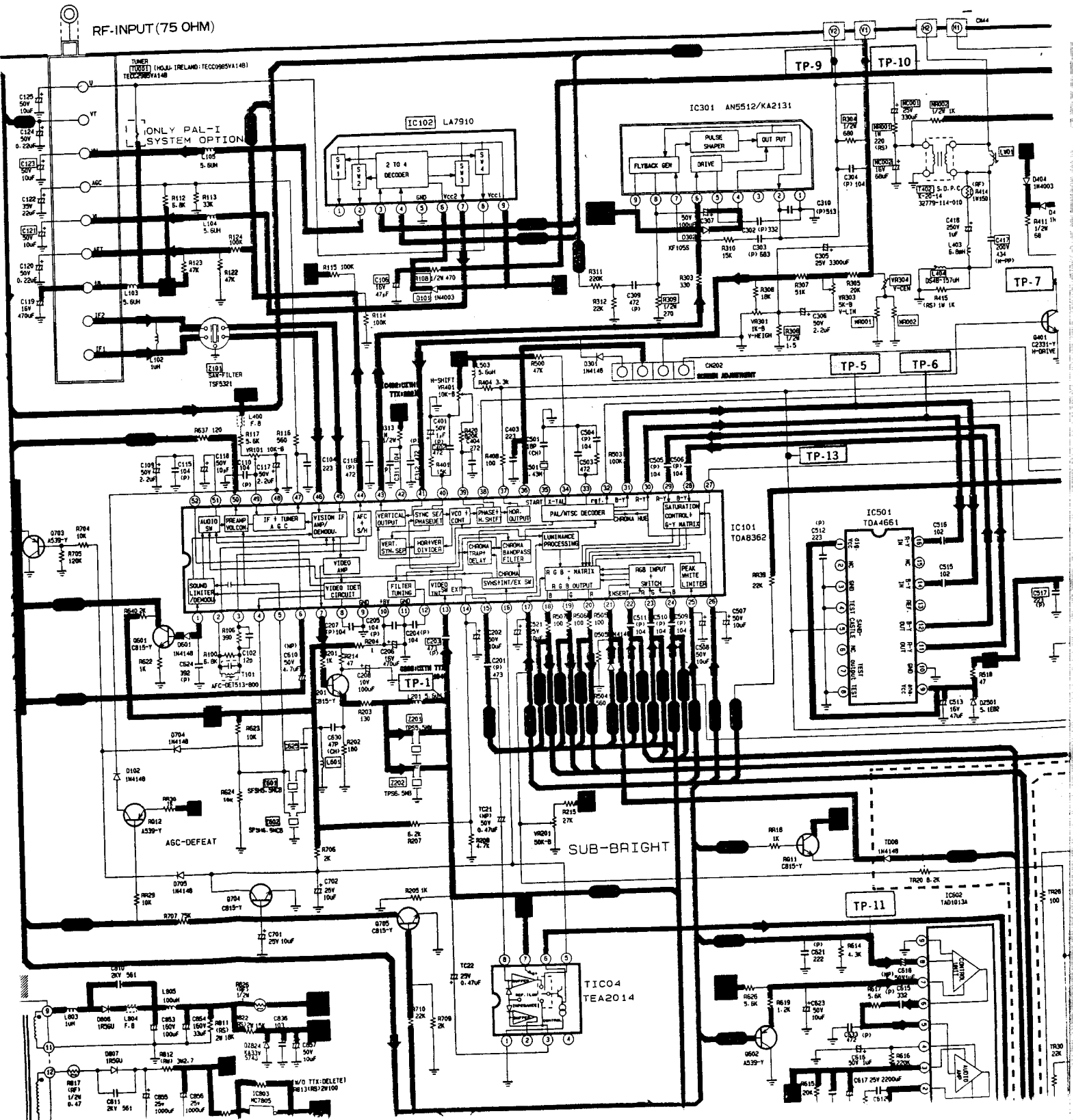



For Service Manuals Contact  
**MAURITRON TECHNICAL SERVICES**  
 8 Cherry Tree Rd, Chinnor  
 Oxon OX9 4QY  
 Tel: 01844-351694 Fax: 01844-352554  
 Email: enquiries@mauritron.co.uk

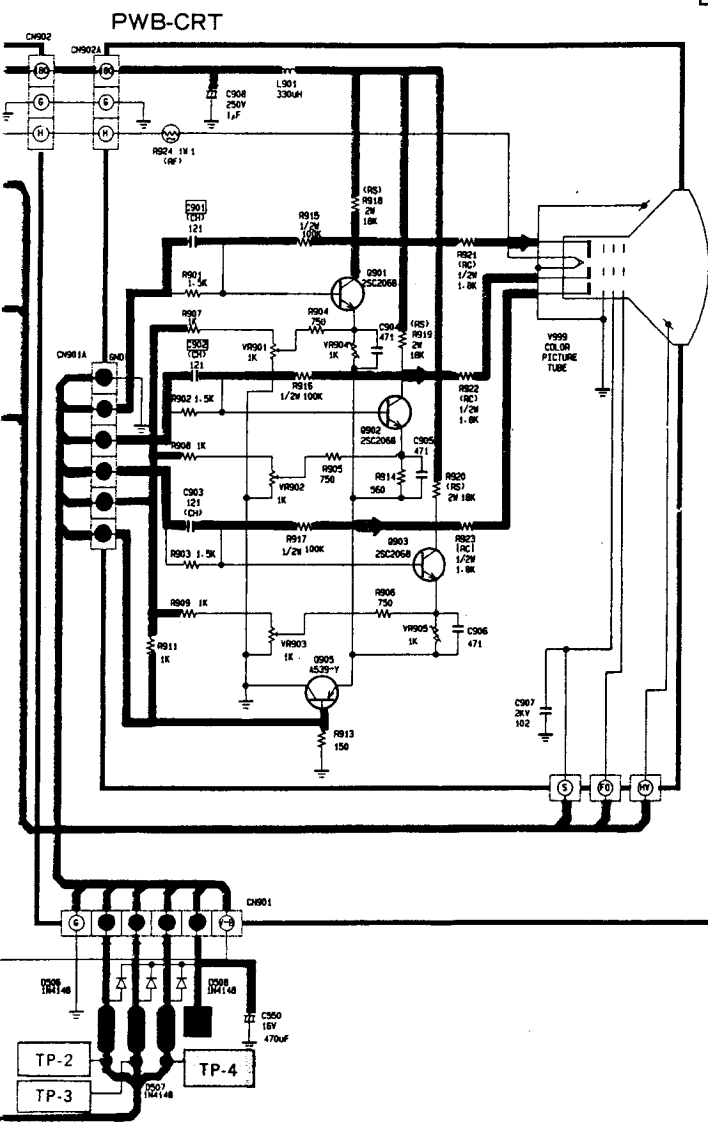

DIFFERNT PARTS FOR SYSTEM DIFFERNT PARTS FOR INCH

LOC NO	PAL-B/G	PAL/SECAM -B-E	PAL/SECAM -B-E-D-E	PAL-1	14 INCH			
					NORMAL	NIHI-HECK	20 INCH	21 INCH
TC502	DELETE	TD48395	TD48395	DELETE				
CS17	DELETE	POLY 223	POLY 223	DELETE	R210	1/2T 133K-F	1/2T 190K-F	1/2T 127K-F
CS18	DELETE	16V 47uF	16V 47uF	DELETE	R925	1W 0.47	DELETE	1W 1
CS19	DELETE	POLY 104	POLY 104	DELETE	C411	1.6KV 722	1.6KV 722	1.6KV 722
CS20	DELETE	POLY 224	POLY 224	DELETE	C417	400V 364	400V 364	200V 434
CS25	C-C CH 47	C-C CH 47	C-C CH 33	C-C CH 47	L404	DS40-157uH	K-20/195uH	DS40-157uH
L501	12uH	12uH	8.2uH	12uH	0402	2501050	2501050	2501051
Z101	DFW1956	DFW1956	TSF5321	TSF5321	NR001	1W 220	DELETE	1W 220
Z201	TP55-5M	TP55-5M	TP55-5M	DELETE	NR002	1/2T 1K	DELETE	1/2T 1K
Z202	DELETE	DELETE	TP55-5M	DELETE	NC001	25V 330uF	DELETE	25V 330uF
Z203	DELETE	DELETE	TP55-5M	DELETE	NC002	15V 68uF	DELETE	15V 68uF
Z601	SFSH5-5M3	SFSH5-5M3	SFSH5-5M3	DELETE	NR001	1/2T 1.2K	DELETE	1/2T 1.2K
Z602	DELETE	DELETE	SFSH5-5M3	DELETE	NR002	1/2T 1.2K	DELETE	1/2T 1.2K
RR20	1/8W 22K	1/8W 22K	1/8W 22K	DELETE	NR003	1/2T 1.2K	DELETE	1/2T 1.2K
RR21	1/8W 22K	1/8W 22K	1/8W 22K	DELETE	TA02	K-20-14	DELETE	K-20-14
RR22	1/8W 10K	1/8W 10K	1/8W 10K	DELETE	LW01		800uH(412-610)	800uH(412-610)
RR23	1/8W 10K	1/8W 10K	1/8W 10K	DELETE	T444	FCM415AL	FCM2014FL	FCM2015AL
R002	CB15-Y	CB15-Y	CB15-Y	DELETE	Y999	51G6891X	A340V42X	37G2822
R003	CB15-Y	CB15-Y	CB15-Y	DELETE	Y999A	B12-2628ASE	HF-22-5A	B12-2628ASE
R100	1/2W 470	1/2W 470	1/2W 470	DELETE	R304	1/2W 680	1/2W 680	1/2W 680
D101	1M4003	1M4003	1M4003	DELETE	C901	50V CH 121	50V CH 121	50V CH 121
C100	16V 47uF	16V 47uF	16V 47uF	DELETE	C902	50V CH 121	50V CH 121	50V CH 101
IC102	LA7910	LA7910	LA7910	DELETE	C412	DELETE	DELETE	2KV 331
C121	50V 10uF	50V 10uF	50V 10uF	DELETE	R306	1/2T 1.5	1/2T 2.2	1/2T 1.5
C123	50V 10uF	50V 10uF	50V 10uF	DELETE	W304		2K-B	5K-B
L104	5.6uH	5.6uH	5.6uH	DELETE	C309	472-J	272-J	472-J
L105	5.6uH	5.6uH	5.6uH	DELETE				
OSCAR	10001	TECC298V14B	TECC298V14B	TECC298V14B				
SANK	0002	DELETE	DELETE	DELETE				
TR002	DELETE	DELETE	DELETE	DELETE				
HYPER	10001	TECC298V15B	TECC298V15B	TECC298V15B				
SANK	0002	IM414B	IM414B	IM414B				
0005	IM414B	IM414B	IM414B	IM414B				

OPTION-PARTS

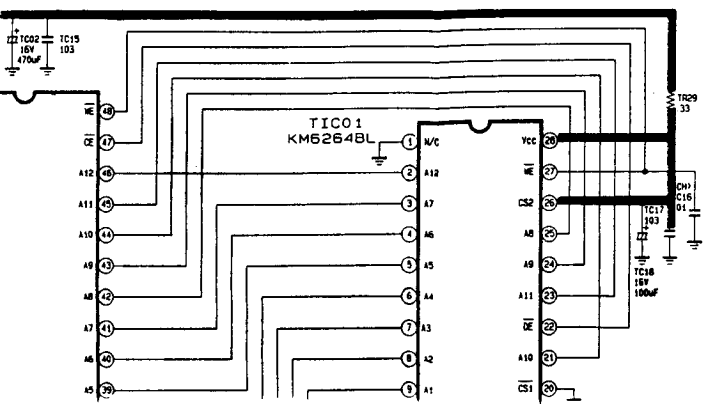

RESISTOR

Carbon	No Mark
Composition (RC)	(RC)
Metal Oxide (RO)	(RO)
Metal Film (RF)	(RF)
Fusible (RF)	(RF)
Cement Wire (RW)	(RW)
Network (RN)	(RN)

CAPACITOR

Ceramic - SL	(SL)
Ceramic - RH	(RH)
Ceramic - CH	(CH)
Polyester(Induct)	(PI)
Polyester(Noninduct)	(PN)
Polypropylene	(PP)
Metal Polyester	(MP)
M. P. Polypropylene	(MPP)
Tantalum	(T)
Non Polar	(NP)

DIFFERNT PARTS FOR TTX GROUP

LOC NO	3GROUP	4GROUP TTX-EUR	5GROUP TTX-EAS/EUR	6GROUP	REMARK
TIC03	SA45246P/42	SA45246P/42	SA45246P/42	SA45246P/42	
TIC02	SA45246P/42	SA45246P/42	SA45246P/42	SA45246P/42	
TIC01	SA45246P/42	SA45246P/42	SA45246P/42	SA45246P/42	
TR12	1/8T 1N	DELETE	DELETE	DELETE	
TC13	50V RH 30	DELETE	DELETE	DELETE	
TC14	50V RH 30	DELETE	DELETE	DELETE	

POWER LINE SIGNAL LINE

EXPRESSION  
 1 Resistance is shown on K=1,000 M=1,000,000  
 2 Unless otherwise noted in schematic all capacitor values less than 1 are expressed in uF, the values more than 1 in pF.  
 3 Unless otherwise noted in schematic all inductor values are expressed in uH and the values less than 1 in mH.  
 NOTE  
 The circuits are subject to change without notice to improve the picture quality.

PWB-TRANSMITTER

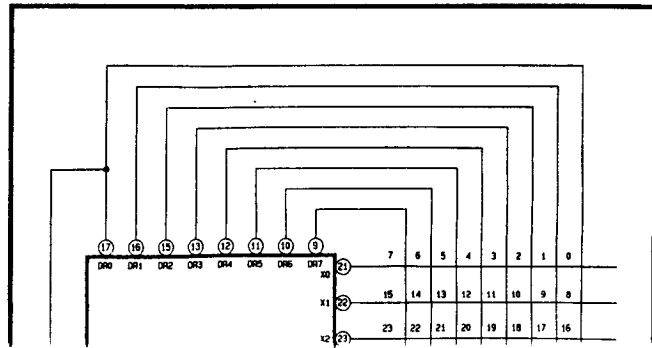

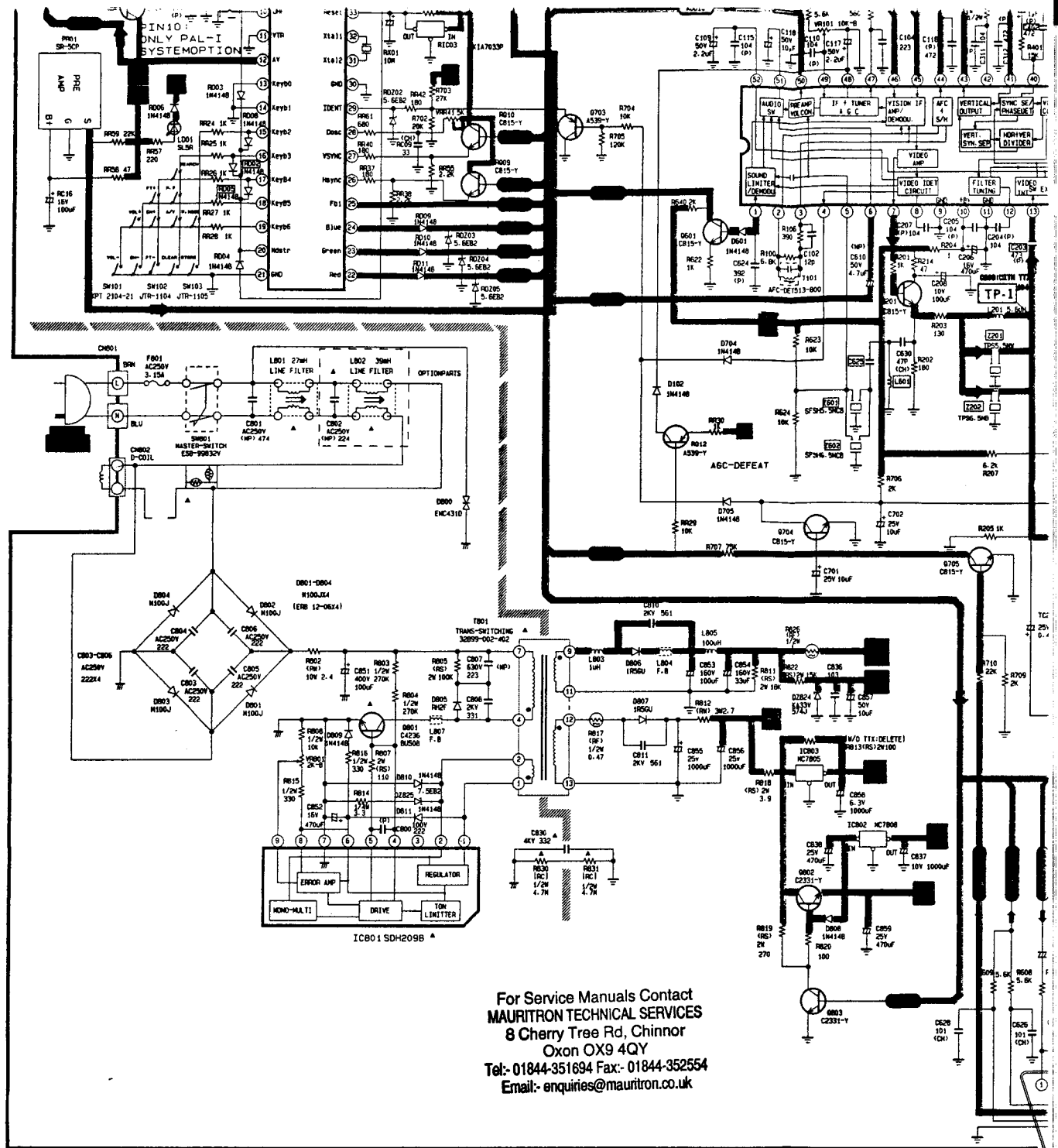

For Service Manuals Contact  
**MAURITRON TECHNICAL SERVICES**  
 8 Cherry Tree Rd, Chinnor  
 Oxon OX9 4QY  
 Tel: 01844-351694 Fax: 01844-352554  
 Email: enquiries@mauritron.co.uk

**TESTPOINT WAVEFORM**

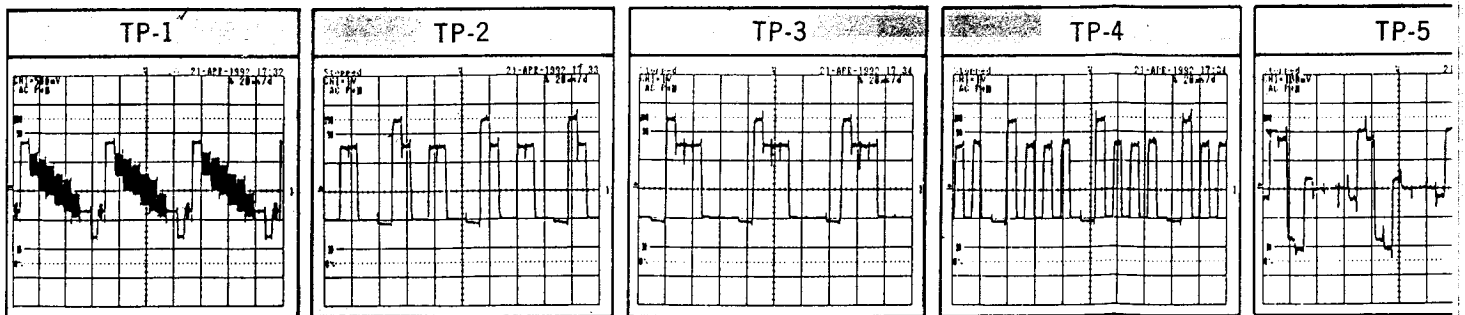

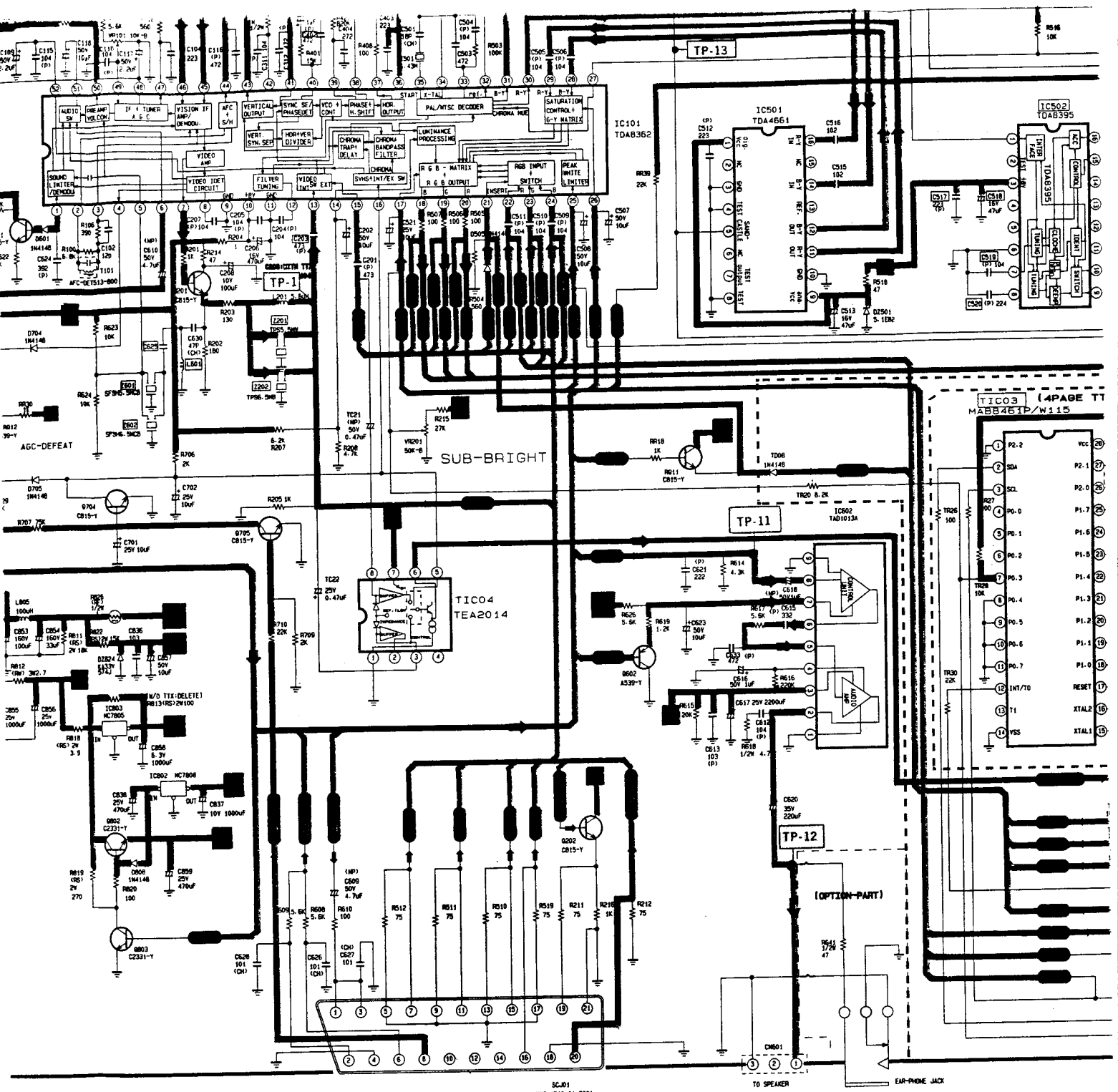

SC-01  
100-1510-01-3004

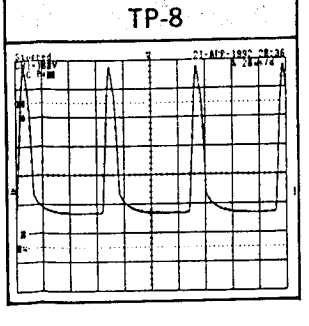
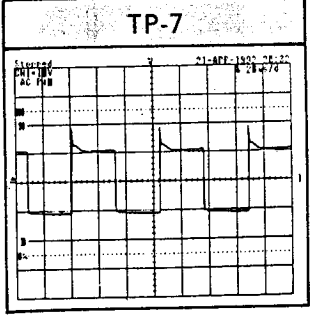
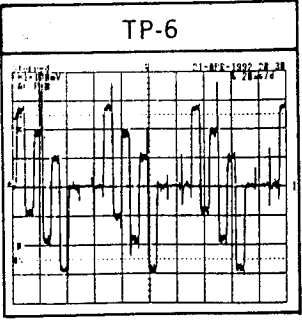
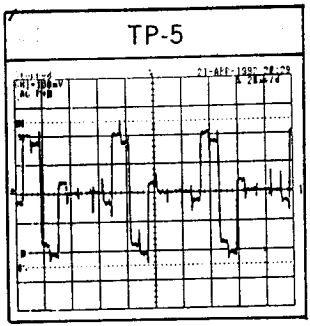
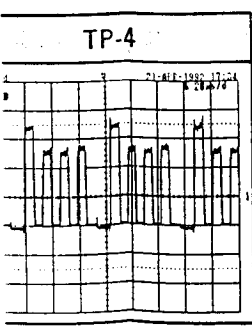

C121  
C123  
L104  
L105  
OSCAMP  
BAND  
HYPER  
BAND  
C6  
Co  
Me  
Fu  
Cr  
Ne  
Ce  
Ce  
Po  
Po  
Me  
H.  
Ta  
No  
F

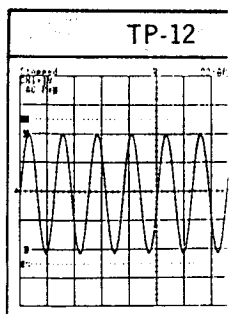
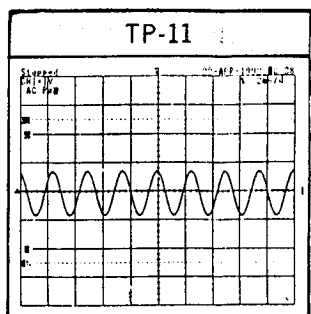
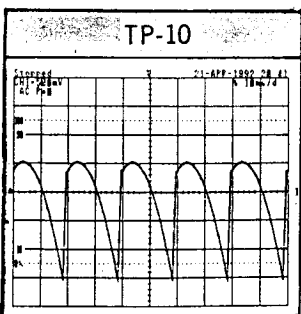
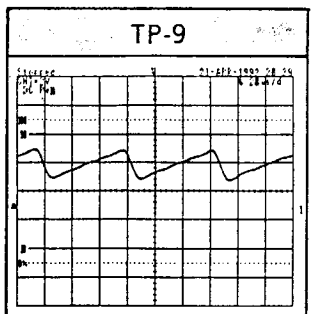
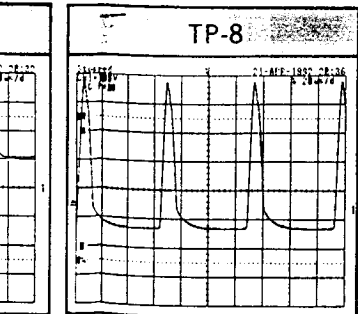
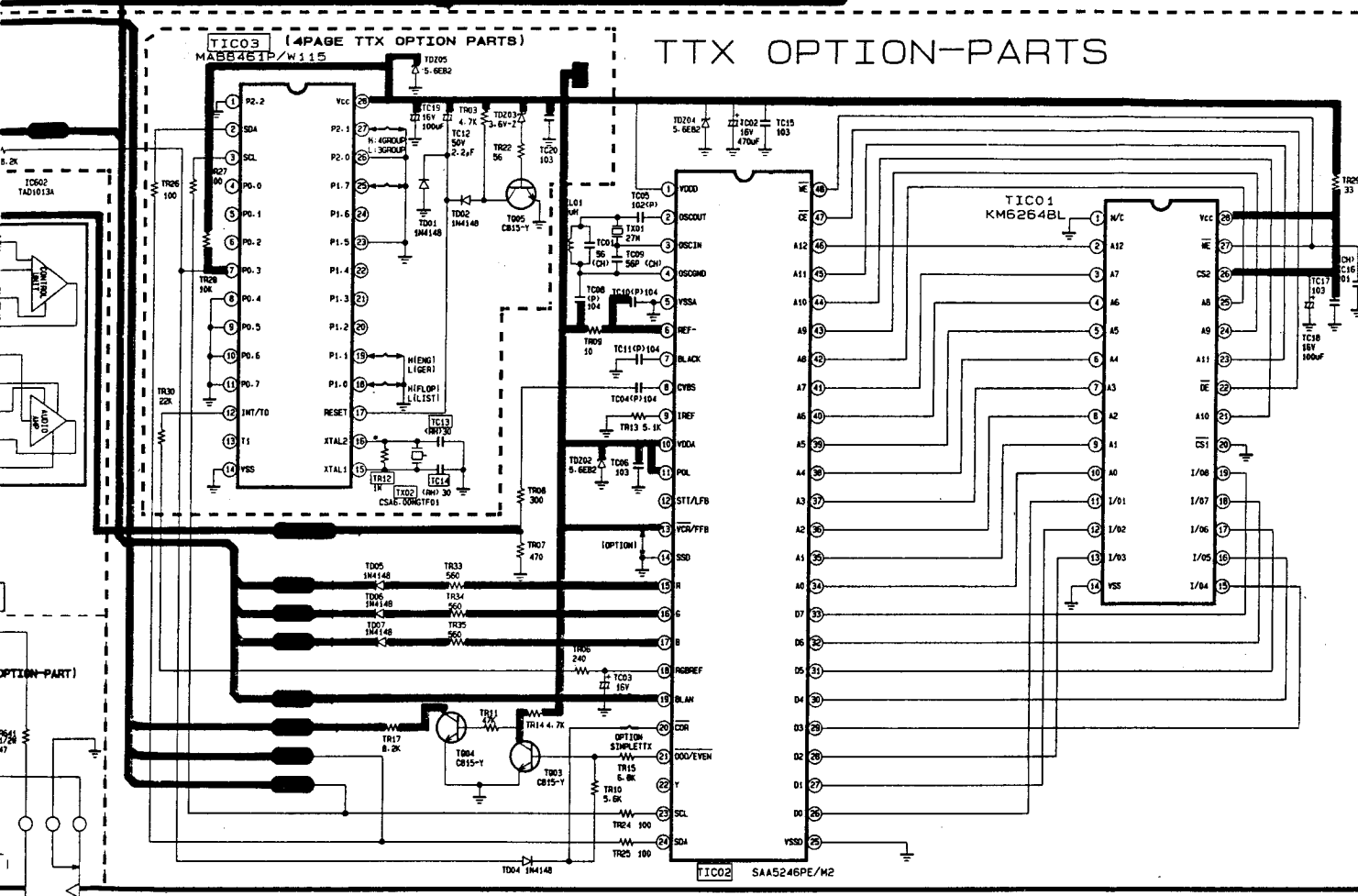
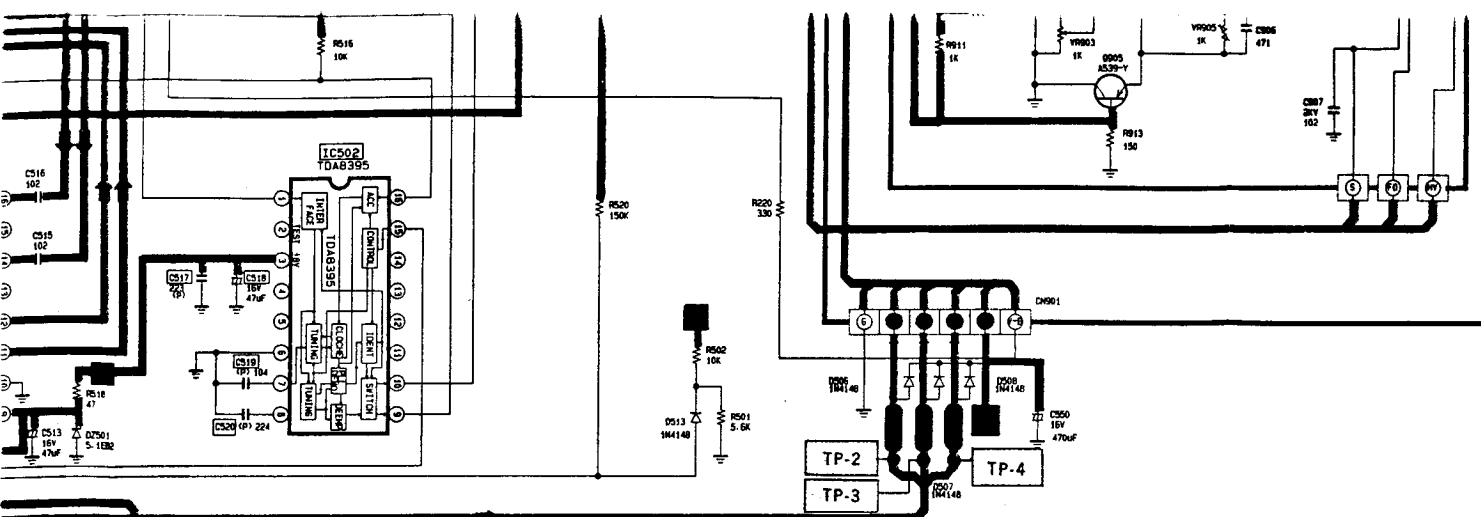

For Service Manuals Contact  
**MAURITRON TECHNICAL SERVICES**  
 8 Cherry Tree Rd, Chinnor  
 Oxon OX9 4QY  
 Tel: 01844-351694 Fax: 01844-352554  
 Email: enquiries@mauritron.co.uk



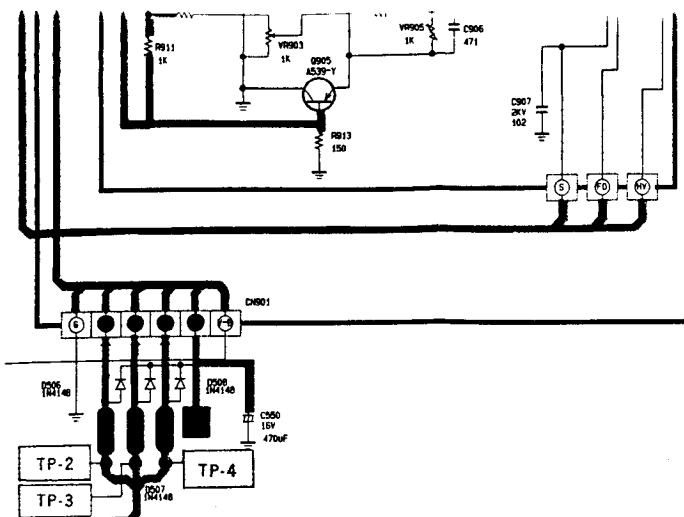

C121	50V 10uF	50V 10uF	50V 10uF	DELETE
C123	50V 10uF	50V 10uF	50V 10uF	DELETE
L104	5.6uH	5.6uH	5.6uH	DELETE
L105	5.6uH	5.6uH	5.6uH	DELETE
OCAPR001	TECC2985V148	TECC2985V148	TECC2985V148	TECC2985V148
-BAND	RECO	DELETE	DELETE	DELETE
TR02	RECO	DELETE	DELETE	DELETE
HYPER	UR01	TECC2985V150	TECC2985V150	TECC2985V150
-BAND	RECO	TR4148	TR4148	TR4148
RECO	TR4148	TR4148	TR4148	TR4148

VR304		2K-8		5K-8
C309	472-J	272-J	472-J	472-J

RESISTOR	
Carbon	NO MARK
Composition	(RC)
Metal Oxide	(RS)
Metal Film	(RM)
Fusible	(RF)
Cement-Wire	(RW)
Network	(RN)

CAPACITOR	
Ceramic - SL	NO MARK
Ceramic - RH	(RH)
Ceramic - CH	(CH)
Polyester(Induct)	(IP)
Polyester(Noninduct)	(PN)
Polypropylene	(PP)
Metal Polyester	(MP)
M. P. Polypropylene	(MPP)
Tantalum	(T)
Non Polar	(NP)

### DIFFERENT PARTS FOR TTX GROUP

LDC NO	3GROUP	4GROUP	5GROUP	6GROUP	REMARK
TIC03	NA8848IP/N115	PCF84C81P/CT1972	PCF84C81P/CT1972	PCF84C81P/CT1972	
TIC02	SA15246PE/M2	SA15246PE/M2	SA15246P/H	SA15246P/T	
X02	CSA6-0046TFO1	9.8304MHZ	9.8304MHZ	9.8304MHZ	
TR12	1/8T 1H	DELETE	DELETE	DELETE	
TC13	50V RH 30	DELETE	DELETE	DELETE	
TC14	50V RH 30	DELETE	DELETE	DELETE	

### POWER LINE SIGNAL LINE

EXPRESSION  
 1 Resistance is shown on K=1,000 M=1,000,000  
 2 Unless otherwise noted in schematic all capacitor values less than 1 are expressed in uF. The values more than 1 in uF.  
 3 Unless otherwise noted in schematic all inductor values are expressed in uH and the values less than 1 in mH.

NOTE  
 The circuits are subject to change without notice to improve the picture quality.

### OPTION-PARTS

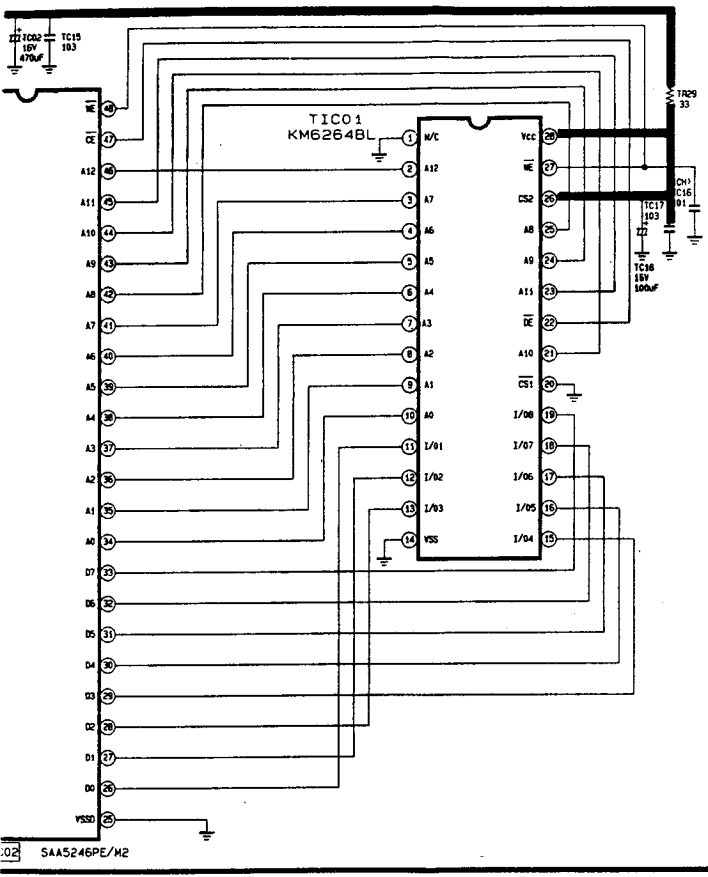

### PWB-TRANSMITTER

