



LG

North/Latin America
Europe/Africa
Asia/Oceania

Internal Use Only

<http://aic.lgservice.com>
<http://eic.lgservice.com>
<http://biz.lgservice.com>

PLASMA TV

SERVICE MANUAL

CHASSIS : PP11K

MODEL : 42PT350R
42PT351R

42PT350R-TD
42PT351R-TC

CAUTION

BEFORE SERVICING THE CHASSIS,
READ THE SAFETY PRECAUTIONS IN THIS MANUAL.

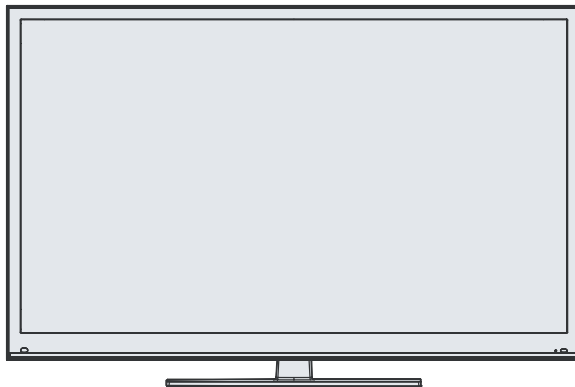

P/NO : MFL67002503 (1102-REV00)

Printed in Korea

CONTENTS

CONTENTS	2
SAFETY PRECAUTIONS	3
SPECIFICATION	4
ADJUSTMENT INSTRUCTION	6
BLOCK DIAGRAM	12
EXPLODED VIEW	13
CIRCUIT DIAGRAM	

SAFETY PRECAUTIONS

IMPORTANT SAFETY NOTICE

Many electrical and mechanical parts in this chassis have special safety-related characteristics. These parts are identified by \triangle in the Schematic Diagram and Exploded View.

It is essential that these special safety parts should be replaced with the same components as recommended in this manual to prevent X-RADIATION, Shock, Fire, or other Hazards.

Do not modify the original design without permission of manufacturer.

General Guidance

An **isolation Transformer should always be used** during the servicing of a receiver whose chassis is not isolated from the AC power line. Use a transformer of adequate power rating as this protects the technician from accidents resulting in personal injury from electrical shocks.

It will also protect the receiver and its components from being damaged by accidental shorts of the circuitry that may be inadvertently introduced during the service operation.

If any fuse (or Fusible Resistor) in this monitor is blown, replace it with the specified.

When replacing a high wattage resistor (Oxide Metal Film Resistor, over 1W), keep the resistor 10mm away from PCB.

Keep wires away from high voltage or high temperature parts.

Due to high vacuum and large surface area of picture tube, extreme care should be used in **handling the Picture Tube**. Do not lift the Picture tube by its Neck.

Leakage Current Cold Check(Antenna Cold Check)

With the instrument AC plug removed from AC source, connect an electrical jumper across the two AC plug prongs. Place the AC switch in the on position, connect one lead of ohm-meter to the AC plug prongs tied together and touch other ohm-meter lead in turn to each exposed metallic parts such as antenna terminals, phone jacks, etc.

If the exposed metallic part has a return path to the chassis, the measured resistance should be between $1M\Omega$ and $5.2M\Omega$.

When the exposed metal has no return path to the chassis the reading must be infinite.

An other abnormality exists that must be corrected before the receiver is returned to the customer.

Leakage Current Hot Check (See below Figure)

Plug the AC cord directly into the AC outlet.

Do not use a line Isolation Transformer during this check.

Connect 1.5K/10watt resistor in parallel with a 0.15uF capacitor between a known good earth ground (Water Pipe, Conduit, etc.) and the exposed metallic parts.

Measure the AC voltage across the resistor using AC voltmeter with 1000 ohms/volt or more sensitivity.

Reverse plug the AC cord into the AC outlet and repeat AC voltage measurements for each exposed metallic part. Any voltage measured must not exceed 0.75 volt RMS which is corresponds to 0.5mA.

In case any measurement is out of the limits specified, there is possibility of shock hazard and the set must be checked and repaired before it is returned to the customer.

Leakage Current Hot Check circuit

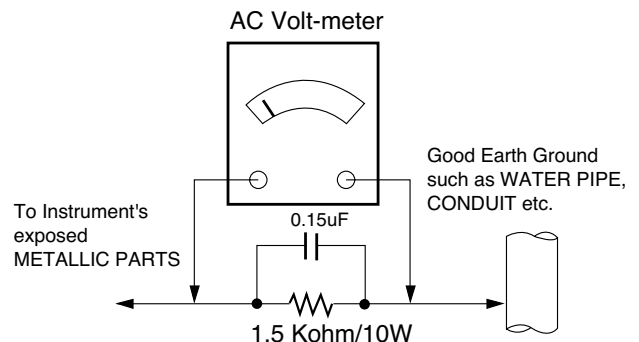

SPECIFICATION

NOTE : Specifications and others are subject to change without notice for improvement.

■ Application Range

This spec is applied to PDP TV used PP11K Chassis.

Model Name	Market Place	Brand
42PT350R-TA 42PT351R-TC	NON-EU	LG

■ Specification

Each part is tested as below without special appointment.

- (1) Temperature : 25 °C ± 5 °C (77 °F ± 9 °F), CST : 40 ± 5
- (2) Relative Humidity: 65 % ± 10 %
- (3) Power Voltage: Standard Input voltage (100 V - 240 V ~, 50 / 60 Hz)
* Standard Voltage of each product is marked by models.
- (4) Specification and performance of each parts are followed each drawing and specification by part number in accordance with SBOM.
- (5) The receiver must be operated for about 20 minutes prior to the adjustment.

■ Test Method

- (1) Performance : LGE TV test method followed.
- (2) Demanded other specification
Safety : CE, IEC specification
EMC : CE, IEC

Model Name	Market	Remark	Appliance
42PT350R-TA 42PT351R-TC	NON-EU	Safety : IEC/ EN60065, EMI : CISPR13	TEST

■ Module Specification

(1) 42" -2D HD

No	Item	Specification	Remark
1	Display Screen Device	106 cm (42 inch) wide Color Display Module	PDP
2	Aspect Ratio	16:9	
3	PDP Module	PDP42T3####,	
		RGB Closed (Well) Type, Glass Filter (38%)	
		Pixel Format: 1024 horiz. By 768 ver	
4	Operating Environment	1) Temp. : 0 deg ~ 40 deg	LGE SPEC
		2) Humidity : 20 % ~ 80 %	
5	Storage Environment	3) Temp. : -20 deg ~ 60 deg	
		4) Humidity : 10 % ~ 90 %	
6	Input Voltage	AC 100 V ~ 240 V, 50 / 60 Hz	Maker LG

■ Model General Specification

(1) NON - EU Spec.(TA)

No	Item		Specification			Remark		
1.	Market		NON EU					
2.	Broadcasting system		PAL/SECAM-BG/I/DK, NTSC-M					
3.	Available Channel		BAND	PAL	NTSC		China(DK)	Australia(BG)
			VHF/UHF CATV	E2 ~ C69 S21 ~ S41	2~78 1~71	VHF/UHF CATV	C1~C62 S1~S41	C1~C75 S2~S44
4.	Receiving system		Upper Heterodyne					
5.	Video Input (2EA)		PAL,SECAM, NTSC			Rear 1EA, Side 1EA		
6.	Component Input (2EA)		Y/Cb/Cr, Y/ Pb/Pr					
7.	RGB Input (1EA)		RGB-PC					
8.	HDMI Input	2ea	HDMI-DTV , Only PCM MODE			Side HDMI(1), Rear HDMI(1) : 42/50PT250R-TA only		
		3ea						
9.	Audio Input (5EA)		L/R Input(PC 1EA, Component 2EA, Rear 1EA, Side 1EA)					
10.	RS-232C (1EA)		Remote control					
11.	USB Input (1EA)		SD DivX, MP3, JPEG,					

ADJUSTMENT INSTRUCTION

1. Application Range

This spec sheet is applied to all of the PP11K chassis.

2. Specification

- (1) Because this is not a hot chassis, it is not necessary to use an isolation transformer. However, the use of isolation transformer will help protect test instrument.
- (2) Adjustment must be done in the correct order.
- (3) The adjustment must be performed in the circumstance of $25\text{ }^{\circ}\text{C} \pm 5\text{ }^{\circ}\text{C}$ of temperature and $65\% \pm 10\%$ of relative humidity if there is no specific designation.
- (4) The input voltage of the receiver must keep 100 V ~ 240 V, 50 / 60 Hz.
- (5) The receiver must be operated for about 5 minutes prior to the adjustment when module is in the circumstance of over $15\text{ }^{\circ}\text{C}$
 - In case of keeping module is in the circumstance of $0\text{ }^{\circ}\text{C}$, it should be placed in the circumstance of above $15\text{ }^{\circ}\text{C}$ for 2 hours
 - In case of keeping module is in the circumstance of below $-20\text{ }^{\circ}\text{C}$, it should be placed in the circumstance of above $15\text{ }^{\circ}\text{C}$ for 3 hours,.

3. S/W Program Download

3-1. Profile

This is for downloading the s/w to the flash memory of the IC402

3-2. Equipment

- (1) PC
- (2) ISP_tool program
- (3) Download jig

3-3. Connection Structure

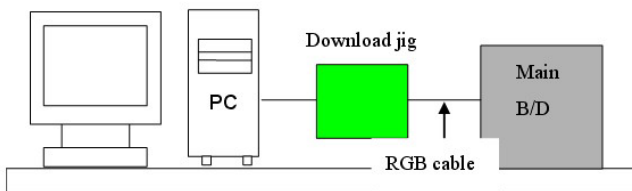

3-4. Connection Condition

- (1) IC name and circuit number : Flash Memory and IC402
- (2) Use voltage : 3.3V (5 pin)
- (3) SCL : 15 pin
- (4) SDA : 12 pin
- (5) Tact time : about 2min and 30seconds

3-5. Download Method (By using MSTAR JIG)

- Preliminary Steps
- (1) Download method (PCB Ass'y)
- HD

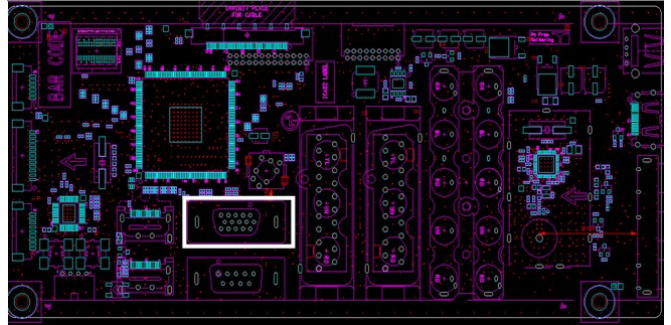

- 1) Connect the download jig to D-sub jack



- 2) Connect the PC to USB jack

- (2) Download Steps

- 1) Execute 'ISP Tool' program in PC, then a main window will be opened

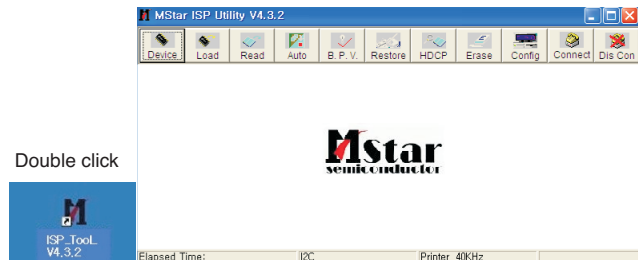

- 2) Click the connect button and confirm "Dialog Box"

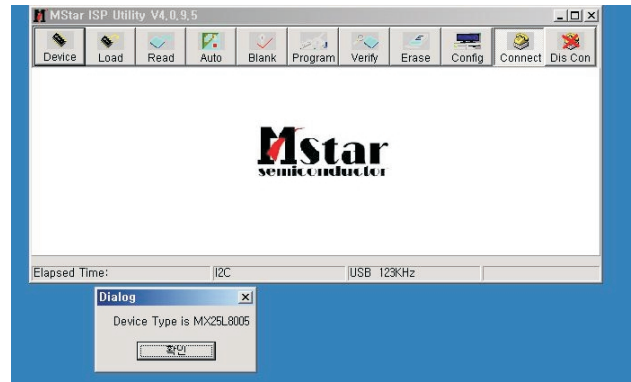

- 3) Click the Config button and Change speed E2PROM Device setting : over the 350Khz

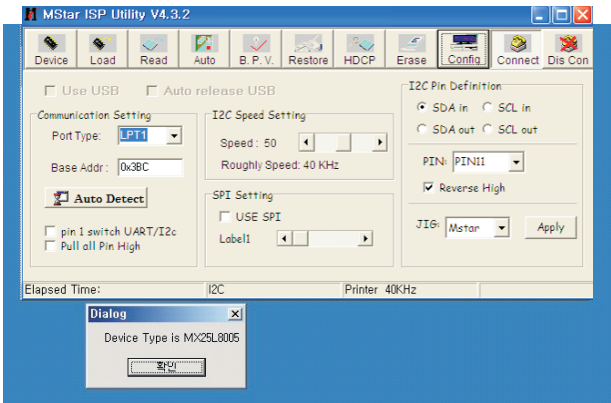

- 4) Read and write bin file
Click "(1)Read" tab, and then load download file(XXXX.bin) by clicking "Read".

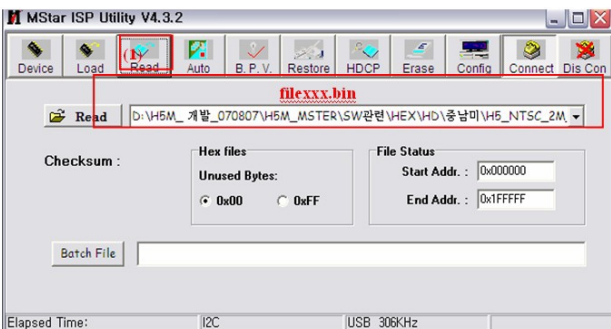

- 5) Click "Auto(2)" tab and set as below
- 6) Click "Run(3)".
- 7) After downloading, check "OK(4)" message.

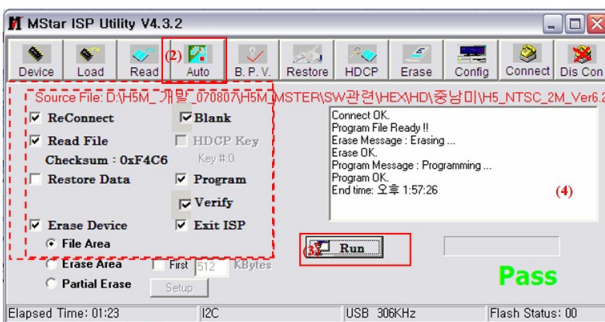

3-6. Download Method (By using USB Memory Stick)

- * Caution
 - Using 'power on' button of the control R/C, power on TV.
 - USB file (EPK) version must be bigger than downloaded version of main B/D.
 - It should be only one SW binary file in USB Stick

- (1) Using 'Power ON' button of the control R/C, Power on TV.
- (2) Insert the USB memory stick to the SET.
- (3) Display USB loading message then, push the 'Exit' Key of control R/C
- (4) Push the 'MENU' Key and move the cursor 'OPTION' of OSD (Fig. 1)

* Caution : Don't push the 'OK' key. Just cursor is on the 'OPTION' menu.



(Fig. 1)

- (5) Push the "7" key of control R/C continuously. Then, Display "TV Software Update" Pop-up menu. (Fig. 2)

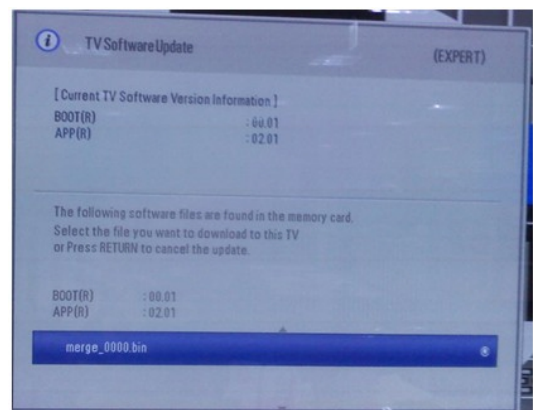

(Fig. 2)

- (6) Select SW file (XXXX.bin) you want, push the "OK" Key.
- (7) S/W download process is executed automatically.

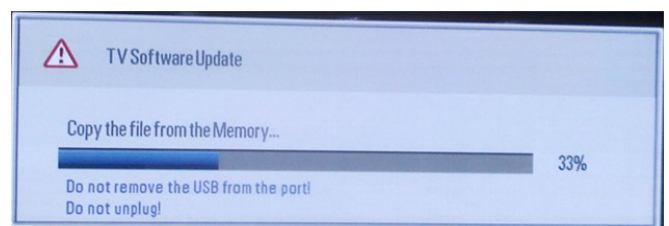

4. PCB Assembly Adjustment Method

4-1. Option Adjustment Following BOM

Tool Option
 Area Option
 Option 1
 Option 2
 Option 3(Available for EU & Non EU model)

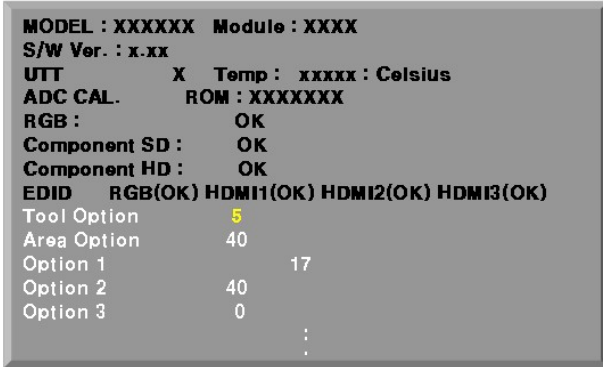

(Fig. 3)

* Profile: Must be changed the option value because being different with some setting value depend on module, inch and market

* Equipment : Adjustment Remote Controller

- (1) Push the IN-START key in the Adjust R/C.
- (2) Enter Password number. The value of Password is "0 0 0 0".



- (3) Input the Option Number that was specified in the BOM, into the Shipping area.
- (4) Select "Tool Option" by using ▲/▼(CH+/-) key, and press the number key(0~9) consecutively
 - ex) If the value of Tool Option1 is 4, input the data using number key "4" (Fig. 3)
- (5) if it is EU model (such as 42/50PJ**R-ZA), select "Area option" by using ▲/▼(CH+/-) key , and press the number key(0~9) consecutively.
 - ex) If the value of Area Option is 40, input the data using number key "40" (Fig. 3)

Caution

- Don't Push "IN-STOP" key after PCB assembly adjustment.

* PP01A/B/C Tool option

Model	Tool option	Area Option
42PT250R-TA	13	1

(6) EDID D/L Method

- After software D/L or PCBA manufacturing, you can download EDID Data.
- When you adjust Tool Option, H6 Model EDID download process is executed automatically

* If the model don't have HDMI 3, HDMI 3 will be disappeared at OSD Window.

[Caution]

- When you adjust tool option, don't connect HDMI or D-sub cable.
- If you connect some cable, EDID D/L process will be failed.

(7) Adjustment method

Before PCBA check, have to change the Tool option and Area option

※ About PDP

After done all adjustments, Press IN-START button and compare Tool option and Area option value with its BOM, if it is correctly same then Change "RF mode" and then unplug the AC cable.

If it is not same, then correct it same with BOM and unplug AC cable.

For correct it to the model's module from factory JIG model.

※ Don't push The IN-STOP KEY after completing the function inspection.

5. EDID(The Extended Display Identification Data)

Caution

- Never Use the cable(HDMI or D-sub cable) for EDID Writing.
- Automatically PP01A/B/C Model EDID download process is executed when you adjust Tool Option.

Inch	
Tool	
SIDE AV	0/1
HDMI	0/1/2/3
Side HDMI	0/1
COMP2	0/1
RGB	0/1
RS232C	0/1
Local Key	0 (7KEY) / 1 (8KEY)
LED TYPE	0 (RED) / 1 (RED/White) / 2 (Reserve)
USB TYPE	0 (NONE) / 1 (PHOTO, MUSIC) / 2 (PHOTO, MUSIC, DivX)

<NON-EU AREA>

Inch	42PT350R-TA
Tool option	15
INCH	42
TOOL	PT350R
SIDE AV	1
HDMI	3
Side HDMI	1
COMP2	1
RGB	1
RS232C	1
Local Key	0
LED TYPE	0
USB TYPE	2

5-1. EDID Data

NO	Item	Condition	Hex Data
1	Manufacturer ID	GSM	1E6D
2	Version	Digital : 1	01
3	Revision	Digital : 3	03

- XGA EDID DATA (42 inch)

<Analog(RGB) : 128bytes>

Addr	00	01	02	03	04	05	06	07	08	09	0A	0B	0C	0D	0E	0F
0000	00	FF	FF	FF	FF	FF	FF	00	1E	6D	01	00	01	01	01	01
0010	01	14	01	03	80	A0	5A	78	0A	D9	B0	A3	57	49	9C	25
0020	11	49	4B	20	00	00	01	01	01	01	01	01	01	01	01	01
0030	01	01	01	01	01	01	01	1D	00	80	51	D0	1C	20	40	80
0040	35	00	BC	88	21	00	00	1E	8C	0A	D0	8A	20	E0	2D	10
0050	10	3E	96	00	13	8E	21	00	00	18	00	00	00	FD	00	3A
0060	3F	1F	32	09	00	0A	20	20	20	20	20	20	20	00	00	FC
0070	00	4C	47	20	54	56	0A	20	20	20	20	20	20	20	01	C3
0080	02	03	26	F1	50	07	01	16	02	03	11	12	13	84	14	05
0090	20	21	22	1F	10	23	09	07	07	83	01	00	00	68	03	0C
00A0	00	30	00	38	2D	00	01	1D	00	80	51	D0	1C	20	40	80
00B0	35	00	BC	88	21	00	00	1E	8C	0A	D0	8A	20	E0	2D	10
00C0	10	3E	96	00	13	8E	21	00	00	18	00	00	00	00	00	00
00D0	00	00	00	00	00	00	00	00	00	00	00	01	1D	80	18	
00E0	71	1C	16	20	58	2C	25	00	C4	8E	21	00	00	9E	00	00
00F0	00	00	00	00	00	00	00	00	00	00	00	00	00	00	00	B1

<HDMI 1 : 256bytes>

Addr	00	01	02	03	04	05	06	07	08	09	0A	0B	0C	0D	0E	0F
0000	00	FF	FF	FF	FF	FF	FF	00	1E	6D	01	00	01	01	01	01
0010	01	14	01	03	80	A0	5A	78	0A	D9	B0	A3	57	49	9C	25
0020	11	49	4B	20	00	00	01	01	01	01	01	01	01	01	01	01
0030	01	01	01	01	01	01	01	1D	00	80	51	D0	1C	20	40	80
0040	35	00	BC	88	21	00	00	1E	8C	0A	D0	8A	20	E0	2D	10
0050	10	3E	96	00	13	8E	21	00	00	18	00	00	00	FD	00	3A
0060	3F	1F	32	09	00	0A	20	20	20	20	20	20	20	00	00	FC
0070	00	4C	47	20	54	56	0A	20	20	20	20	20	20	20	01	C3
0080	02	03	26	F1	50	07	01	16	02	03	11	12	13	84	14	05
0090	20	21	22	1F	10	23	09	07	07	83	01	00	00	68	03	0C
00A0	00	30	00	38	2D	00	01	1D	00	80	51	D0	1C	20	40	80
00B0	35	00	BC	88	21	00	00	1E	8C	0A	D0	8A	20	E0	2D	10
00C0	10	3E	96	00	13	8E	21	00	00	18	00	00	00	00	00	00
00D0	00	00	00	00	00	00	00	00	00	00	00	01	1D	80	18	
00E0	71	1C	16	20	58	2C	25	00	C4	8E	21	00	00	9E	00	00
00F0	00	00	00	00	00	00	00	00	00	00	00	00	00	00	00	D1

<HDMI 2 : 256bytes>

Addr	00	01	02	03	04	05	06	07	08	09	0A	0B	0C	0D	0E	0F
0000	00	FF	FF	FF	FF	FF	FF	00	1E	6D	01	00	01	01	01	01
0010	01	14	01	03	80	A0	5A	78	0A	D9	B0	A3	57	49	9C	25
0020	11	49	4B	20	00	00	01	01	01	01	01	01	01	01	01	01
0030	01	01	01	01	01	01	01	1D	00	80	51	D0	1C	20	40	80
0040	35	00	BC	88	21	00	00	1E	8C	0A	D0	8A	20	E0	2D	10
0050	10	3E	96	00	13	8E	21	00	00	18	00	00	00	FD	00	3A
0060	3F	1F	32	09	00	0A	20	20	20	20	20	20	20	00	00	FC
0070	00	4C	47	20	54	56	0A	20	20	20	20	20	20	20	01	C3
0080	02	03	26	F1	50	07	01	16	02	03	11	12	13	84	14	05
0090	20	21	22	1F	10	23	09	07	07	83	01	00	00	68	03	0C
00A0	00	30	00	38	2D	00	01	1D	00	80	51	D0	1C	20	40	80
00B0	35	00	BC	88	21	00	00	1E	8C	0A	D0	8A	20	E0	2D	10
00C0	10	3E	96	00	13	8E	21	00	00	18	00	00	00	00	00	00
00D0	00	00	00	00	00	00	00	00	00	00	00	01	1D	80	18	
00E0	71	1C	16	20	58	2C	25	00	C4	8E	21	00	00	9E	00	00
00F0	00	00	00	00	00	00	00	00	00	00	00	00	00	00	00	C1

<HDMI 3 : 256bytes> SIDE HDMI(HDMI 3)

Addr	00	01	02	03	04	05	06	07	08	09	0A	0B	0C	0D	0E	0F
0000	00	FF	FF	FF	FF	FF	FF	00	1E	6D	01	00	01	01	01	01
0010	01	14	01	03	80	A0	5A	78	0A	D9	B0	A3	57	49	9C	25
0020	11	49	4B	20	00	00	01	01	01	01	01	01	01	01	01	01
0030	01	01	01	01	01	01	01	1D	00	80	51	D0	1C	20	40	80
0040	35	00	BC	88	21	00	00	1E	8C	0A	D0	8A	20	E0	2D	10
0050	10	3E	96	00	13	8E	21	00	00	18	00	00	00	FD	00	3A
0060	3F	1F	32	09	00	0A	20	20	20	20	20	20	20	00	00	FC
0070	00	4C	47	20	54	56	0A	20	20	20	20	20	20	20	01	C3
0080	02	03	26	F1	50	07	01	16	02	03	11	12	13	84	14	05
0090	20	21	22	1F	10	23	09	07	07	83	01	00	00	68	03	0C
00A0	00	30	00	38	2D	00	01	1D	00	80	51	D0	1C	20	40	80
00B0	35	00	BC	88	21	00	00	1E	8C	0A	D0	8A	20	E0	2D	10
00C0	10	3E	96	00	13	8E	21	00	00	18	00	00	00	00	00	00
00D0	00	00	00	00	00	00	00	00	00	00	00	00	01	1D	80	18
00E0	71	1C	16	20	58	2C	25	00	C4	8E	21	00	00	9E	00	00
00F0	00	00	00	00	00	00	00	00	00	00	00	00	00	00	00	B1

6. HDCP(High-Bandwidth Digital Contents Protection) Download

HDCP download process is deleted in PP01A/B/C Chassis
In PP01A/B/C Chassis, it is using the EEPROM masking HDCP Key

7. Manual ADC Adjustment (Component 1, RGB)

Caution

- Do not connect external input cable
- Adjustment result is applied to SET On/Off later.

RF input	AV / Component / RGB input
NO SIGNAL or White noise	NO SIGNAL

* Adjustment is done using internal ADC, so input signal is not necessary.

7-1. COMPONENT input ADC (SD / HD), RGB input ADC

- (1) Press ADJ key on R/C for adjustment. Need not convert input mode.
- (2) Enter Password number. The value of Password is "0 0 0".
- (3) Select "0. ADC calibration" by using ▲/▼(CH +/-) and press ENTER(■).
- (4) Start ADC adjustment by using ◀/▶(VOL +/-) or press ENTER(■).
- (5) Both component and RGB ADC adjustment are executed automatically



When ADC adjustment is finished, this OSD appear.

Notice : After All mode check, set the Speaker Volume "0".

Caution : Don't Press the Power Key on Remote Controller.
Just AC Power Off. (Not DC off)

Notice : From this sentence, All working is mass production.

8. POWER PCB Assy Voltage Adjustment (Vs voltage Adjustment)

8-1. Test Equipment: D.M.M 1EA

8-2. Connection Diagram for Measuring

Refer to (Fig. 4)

8-3. Adjustment Method

- (1) Vs Adjustment
 - 1) Connect + terminal of D. M..M. to Vs pin of P811, connect -terminal to GND pin of P811.
 - 2) After turning VR901, voltage of D.M.M adjustment as same as Vs voltage which on label of panel right/top (deviation ; $\pm 0.5V$)
- (2) Va Adjustment
 - 1) Connect + terminal of D. M..M. to Va pin of P811, connect -terminal to GND pin of P811.
 - 2) After turning VR502, voltage of D.M.M adjustment as same as Va voltage which on label of panel right/top (deviation ; $\pm 0.5 V$)

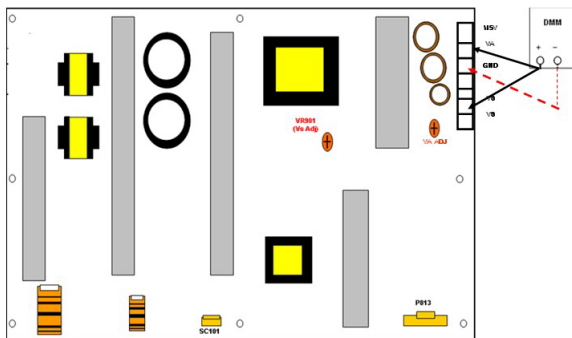

(Fig. 4)

8-4. Adjustment of Area option.

- (1) Area Option Adjustment following BOM (Including SKD models)
 - Tool Option
 - Area Option
 - Option 1
 - Option 2
 - Option 3 (Available for EU & Non EU model)

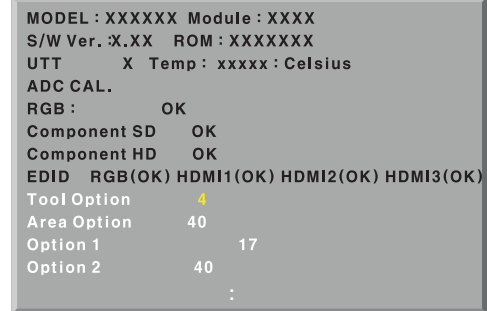

* Profile : Must be changed the option value because being different with some setting value depend on module, inch and market

* Equipment : Adjustment Remote Controller

- 1) Push the IN-START key in the Adjust R/C.
- 2) Enter Password number. The value of Password is "0 0 0".



- 3) Input the Area Option Number that was specified in the BOM, into the Shipping area.
- 4) Select "Area Option" by using ▲/▼(CH+/-) key, and press the number key(0~9) consecutively
- ex) If the value of Area Option 40, input the data using number key "40" (Fig. 3)

Caution:

- Although it is SKD model, adjust area option in SET assembly process.
- Don't Push "IN-STOP" key after PCB assembly adjustment.

9. Adjustment of White Balance

9-1. Required Equipment

- (1) Remote controller for adjustment
- (2) Color Analyzer (CS-1000, CA-100,100+,CA-210 or same produc : CH 10 (PDP)
lease adjust CA-210, CA-100+ by CS-1000 before measuring
- (3) Auto W/B adjustment instrument(only for Auto adjustment)

9-2. AUTO White Balance Process.

Before Adjust of White Balance, Please press POWER ONLY key

Adjust Process will start by execute RS232C Command.

- CS-1000/CA-100+/CA-210(CH 10) White balance adjustment coordinates and color temperature.

CSM	Color Coordinate		Temp	Color Coordinate
	x	y		
Cool	0.276	0.283	11000K	0.002
Medium	0.285	0.293	9300K	0.002
Warm	0.313	0.329	6500K	0.002

9-3. Manual W/B process (using adjusts Remote control)

- (1) Enter 'PICTURE RESET' on Picture Mode, then turn off Fresh Contrast and Fresh colour in Advanced Control
- (2) After enter Service Mode by pushing "ADJ" key,
- (3) Enter White Pattern off of service mode, and change off -> on.
- (4) Enter "W/B ADJUST" by pushing "▶" key at "3. W/B ADJUST".
- (5) Adjust W/B DATA, for all CSM, choose 'COPY ALL'

* Gain Max Value is 192. So, Never make any Gain Value over 192 and please fix one Value on 192, between R, G and B.

	Min	Tpy	Max
R-GAIN	0	192	192
G-GAIN	0	192	192
B-GAIN	0	192	192

* Auto-control interface and directions

- (1) Adjust in the place where the influx of light like floodlight around is blocked. (Illumination is less than 10ux).
- (2) Measure and adjust after sticking the Color Analyzer (CA-100+, CA210) to the side of the module.
- (3) Aging time
After aging start, keep the Power on (no suspension of power supply) and heat-run over 5 minutes

* Above optical characteristics are should be measured by following condition.

	Measured Mode
Picture Mode	Vivid
Fresh Contrast	Off
Fresh Color	Off
Smart Power Saving	Off

● DDC Adjustment Command Set

No.	Adjustment content	CMD(HEX)	ADR	VALUE	detail
1	Aging On/Off	F3	00	FF/00	00 : OFF 01 : ON FF : WB Ready
2	Input select	F4	00		0x10 : TV 0x20 : AV1 0x21 : AV2 0x23 : AV3 0x40 : Component1 0x41 : Component2 0x60 : RGB PC 0x90 : HDMI1 0x91 : HDMI2 0x92 : HDMI3
3	R GAIN	16	00	00 - FE	Gain Adjustment
4	G GAIN	18		00 - FE	CSM COOL
5	B GAIN	1A		00 - FE	
6	R GAIN	16	01	00 - FE	Gain Adjustment
	G GAIN	18		00 - FE	CSM MEDIUM
	B GAIN	1A		00 - FE	
	R GAIN	16	02	00 - FE	Gain Adjustment
	G GAIN	18		00 - FE	CSM WARM
	B GAIN	1A		00 - FE	
	CSM mode	F2	00	00	COOL
				01	MEDIUM
				02	WARM
	EEPROM Read	E7	00	00	EEPROM read
	EEPROM Write	E8	00	data	EEPROM write

10. Default Value in Adjustment mode

10-1. White Balance

(Default values maybe modified the module condition)



10-2. System control condition

1. AC on time on only one after assembled automatically

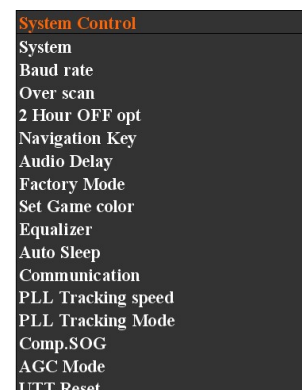

BLOCK DIAGRAM

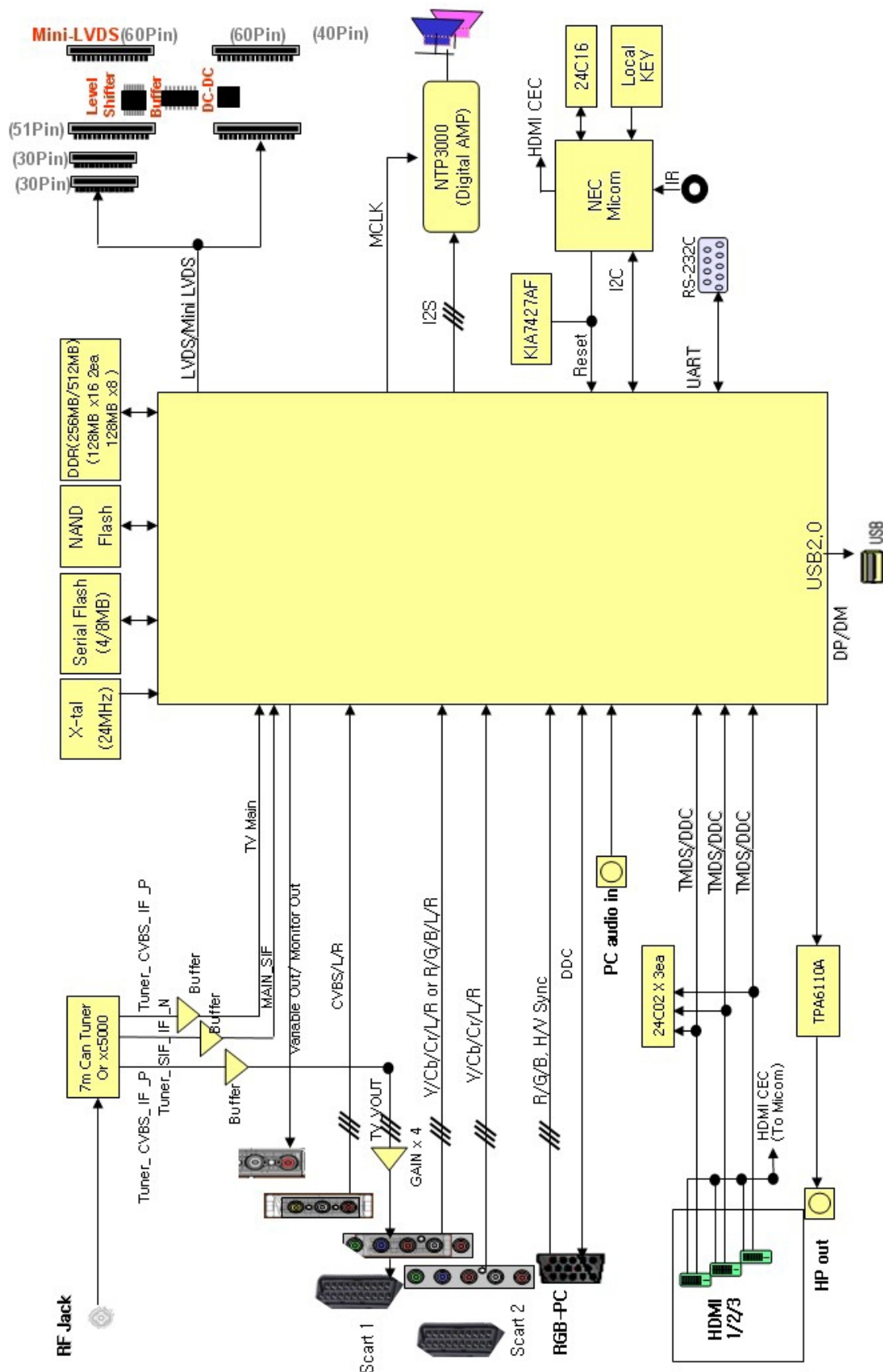

EXPLODED VIEW

IMPORTANT SAFETY NOTICE

Many electrical and mechanical parts in this chassis have special safety-related characteristics. These parts are identified by Δ in the Schematic Diagram and EXPLODED VIEW. It is essential that these special safety parts should be replaced with the same components as recommended in this manual to prevent X-RADIATION, Shock, Fire, or other Hazards. Do not modify the original design without permission of manufacturer.

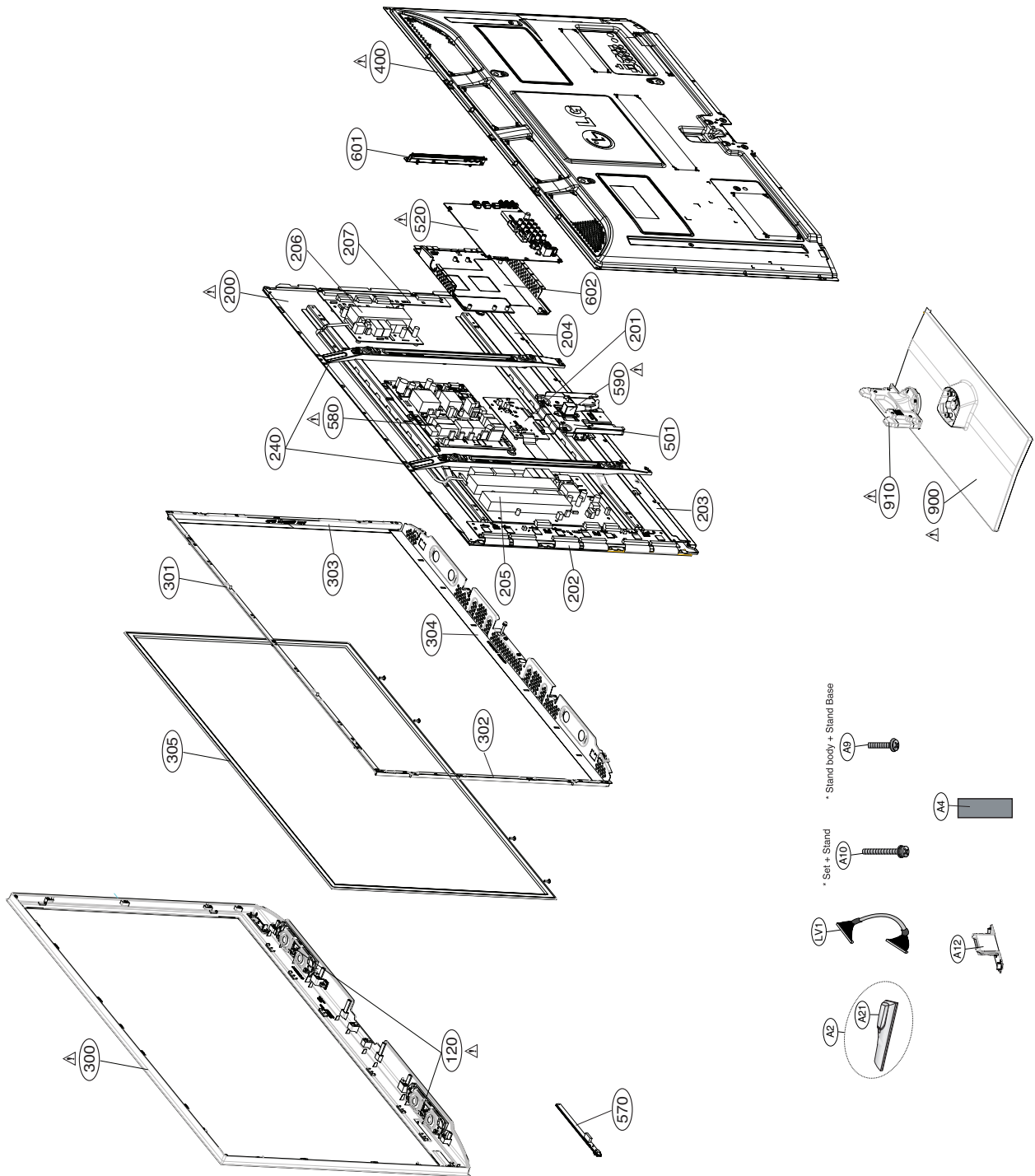

EAX64103901(BPR) H6 Revolution Circuit Diagram

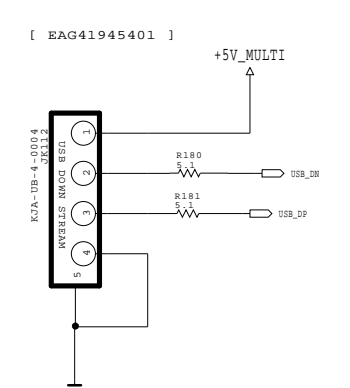
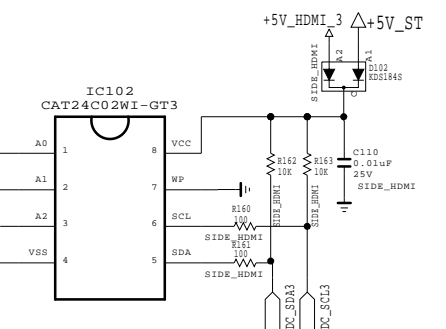
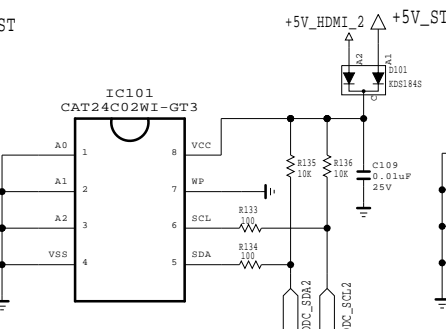
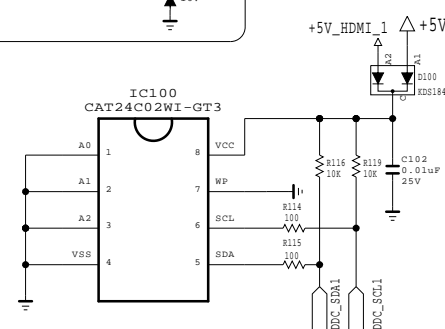
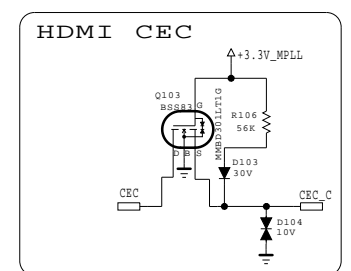
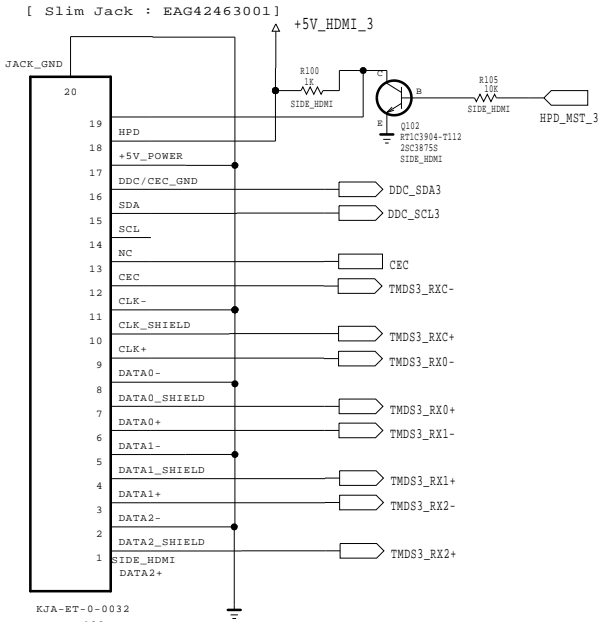
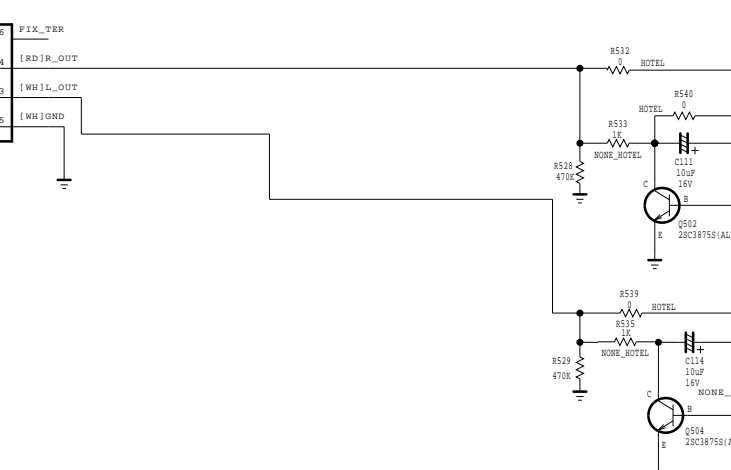
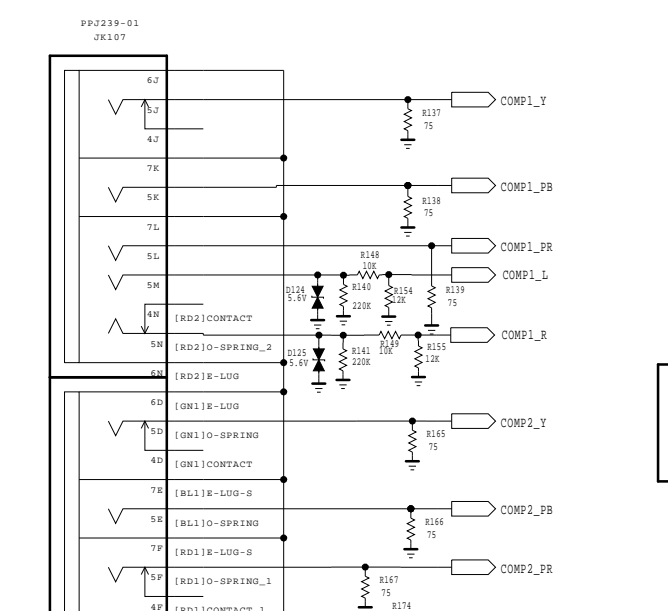
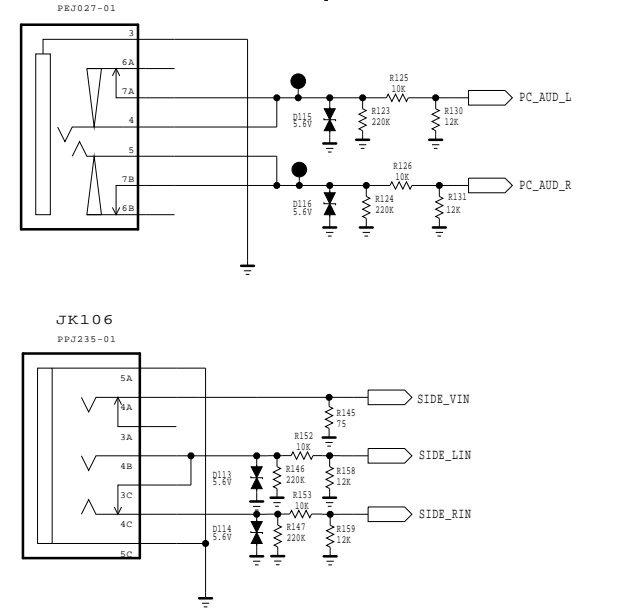
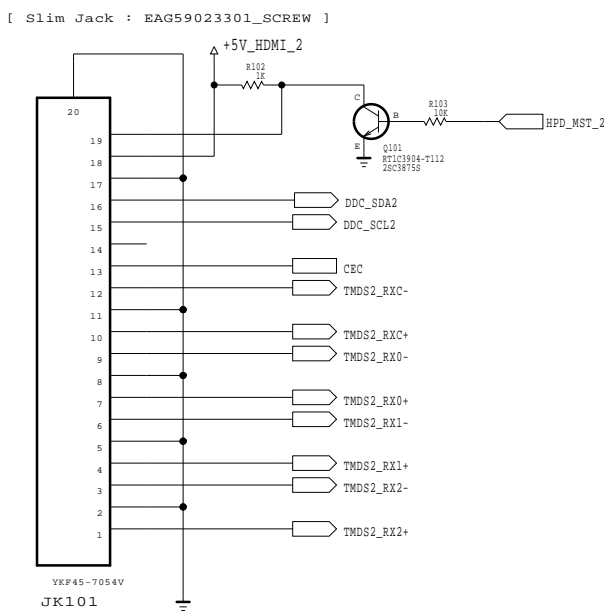
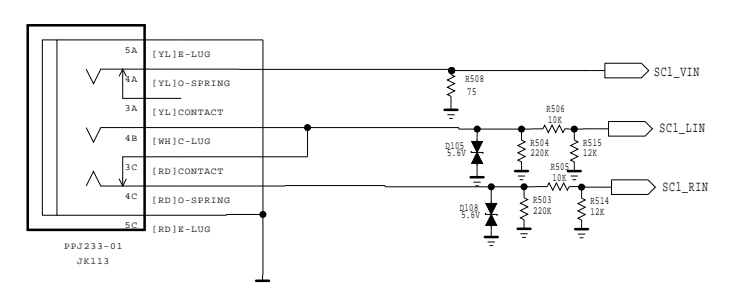
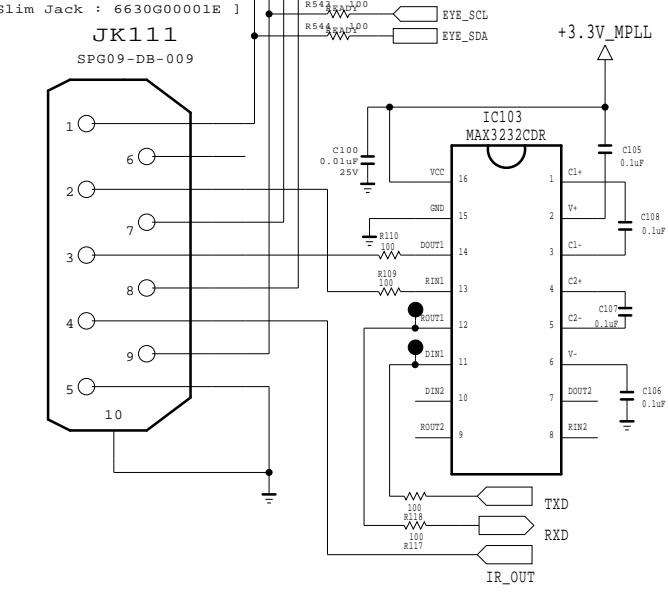
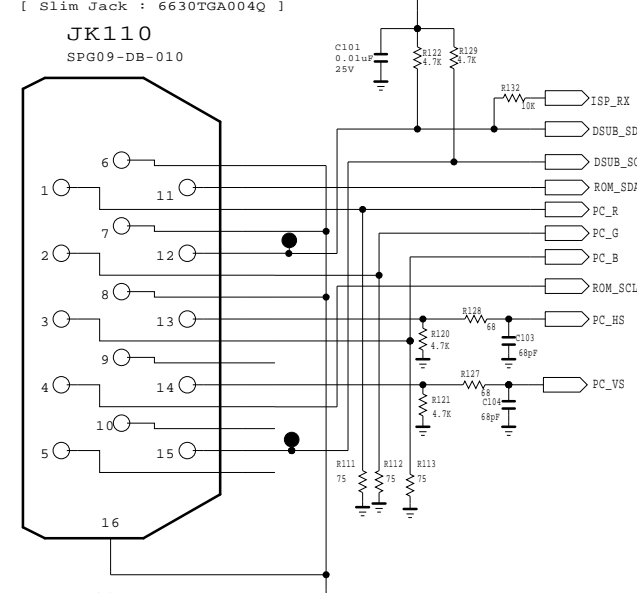
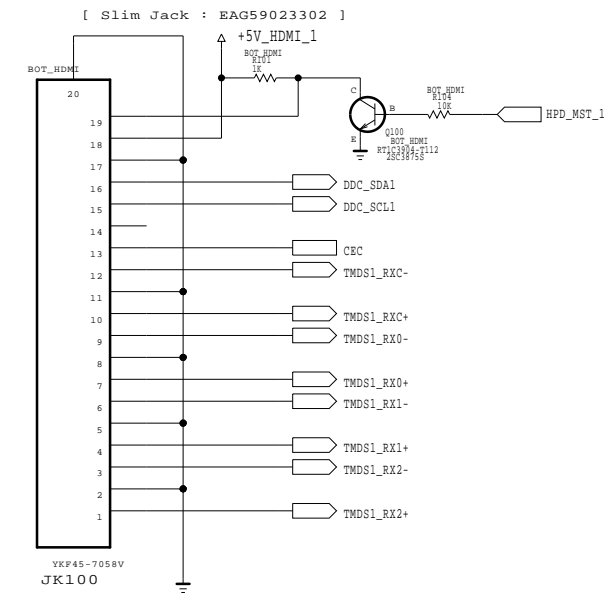

THE SYMBOL MARK OF THIS SCHEMATIC DIAGRAM INCORPORATES SPECIAL FEATURES IMPORTANT FOR PROTECTION FROM X-RADIATION. FILRE AND ELECTRICAL SHOCK HAZARDS, WHEN SERVICING IF IS ESSENTIAL THAT ONLY MANUFACTURES SPECIFIED PARTS BE USED FOR THE CRITICAL COMPONENTS IN THE SYMBOL MARK OF THE SCHEMATIC.

SECRET
LGElectronics



MODEL	H6RR	DATE	2010/11/1
BLOCK	INPUT	SHEET	1 / 4

EAX64103901(BPR)
H6 Revolution Circuit Diagram
Power Block

LVDS Block

KEY/IR Interface

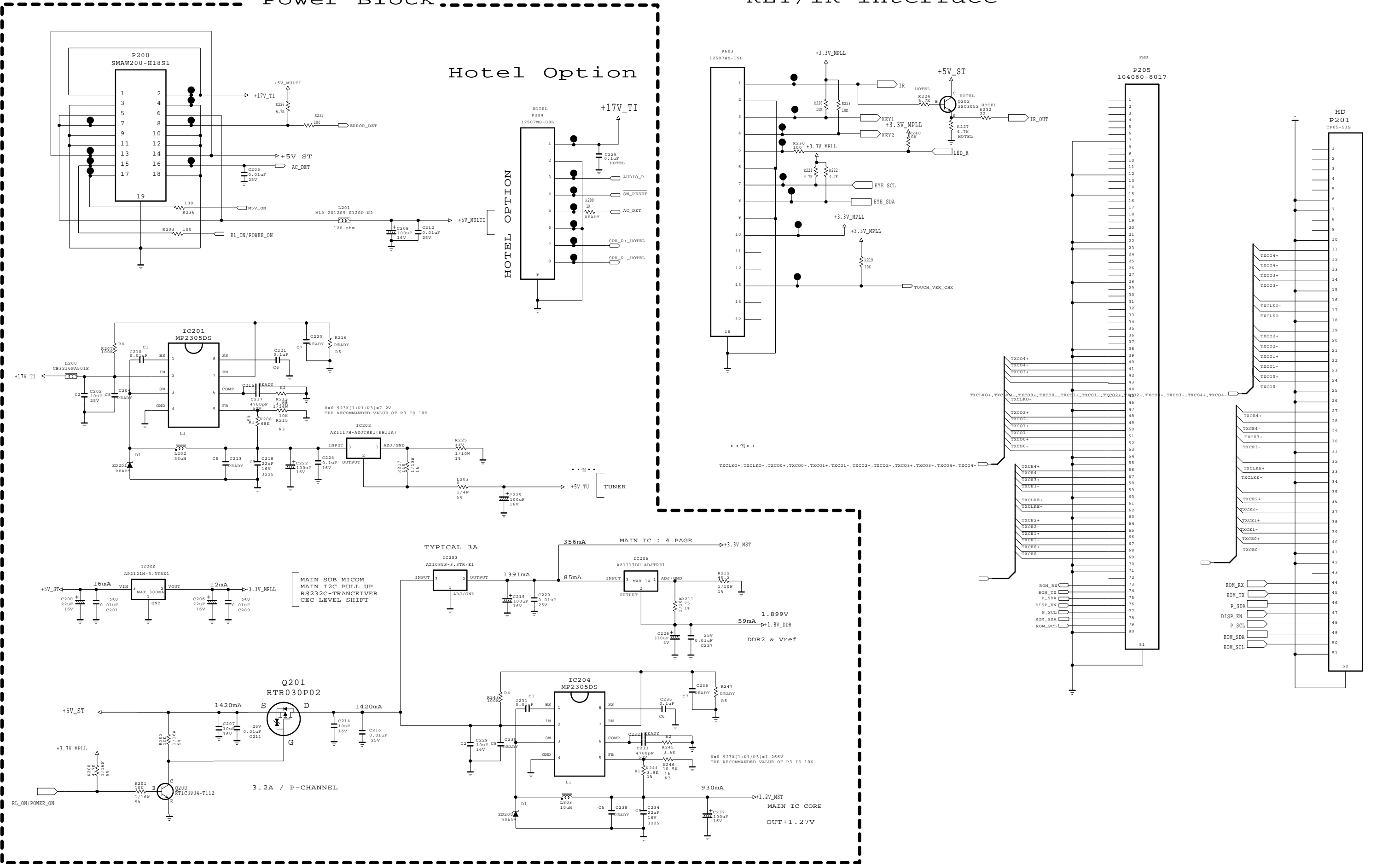

THE Δ SYMBOL MARK OF THIS SCHEMATIC DIAGRAM INCORPORATES SPECIAL FEATURES IMPORTANT FOR PROTECTION FROM X-RADIATION. FILRE AND ELECTRICAL SHOCK HAZARDS, WHEN SERVICING IF IS ESSENTIAL THAT ONLY MANUFACTURES SPECIFIED PARTS BE USED FOR THE CRITICAL COMPONENTS IN THE Δ SYMBOL MARK OF THE SCHEMATIC.

SECRET
LGElectronics



MODEL	H6RR	DATE	2010/11/1
BLOCK	Key / Power	SHEET	2 / 4

EAX64103901 (BPR)
H6 Revolution Circuit Diagram

Audio Amp

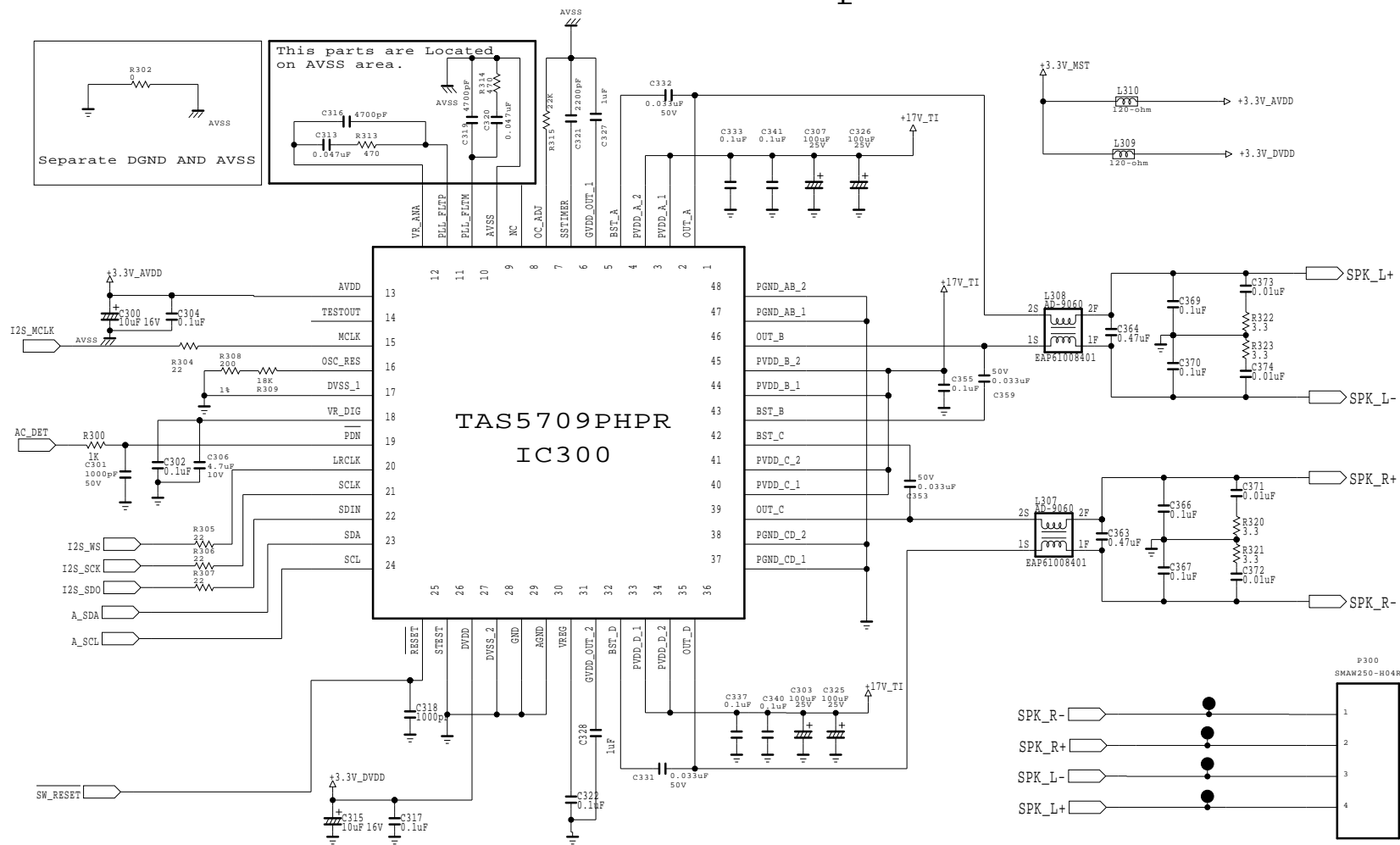

Tuner (7mm)

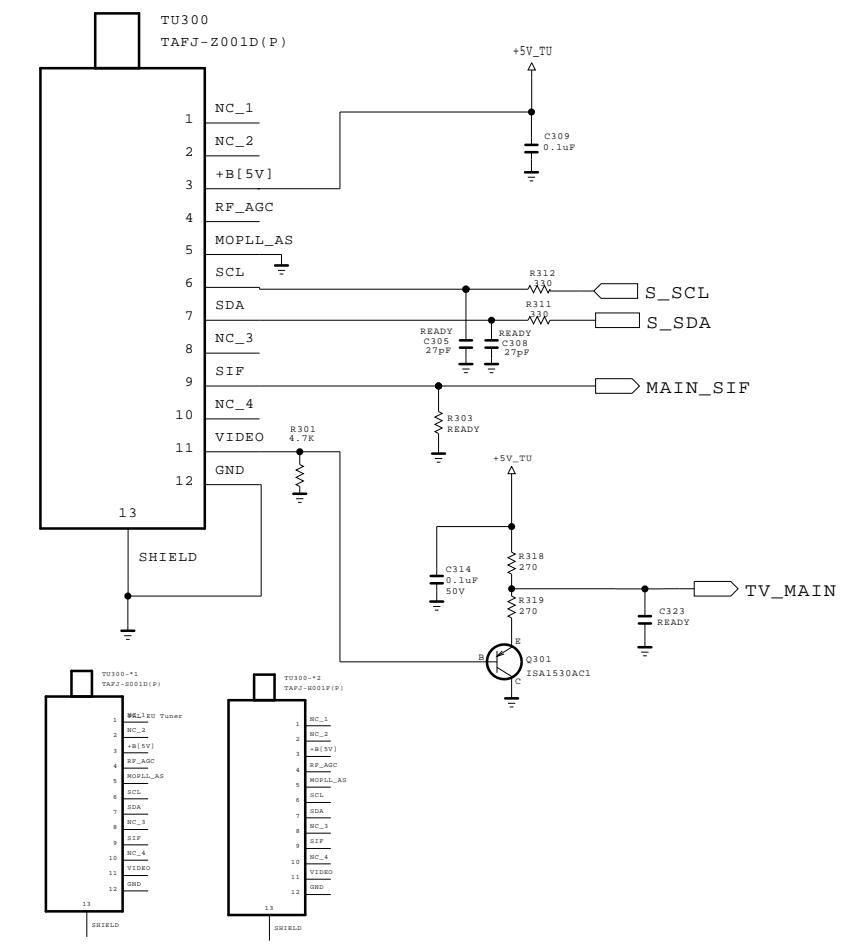

DDR Memory for Main IC

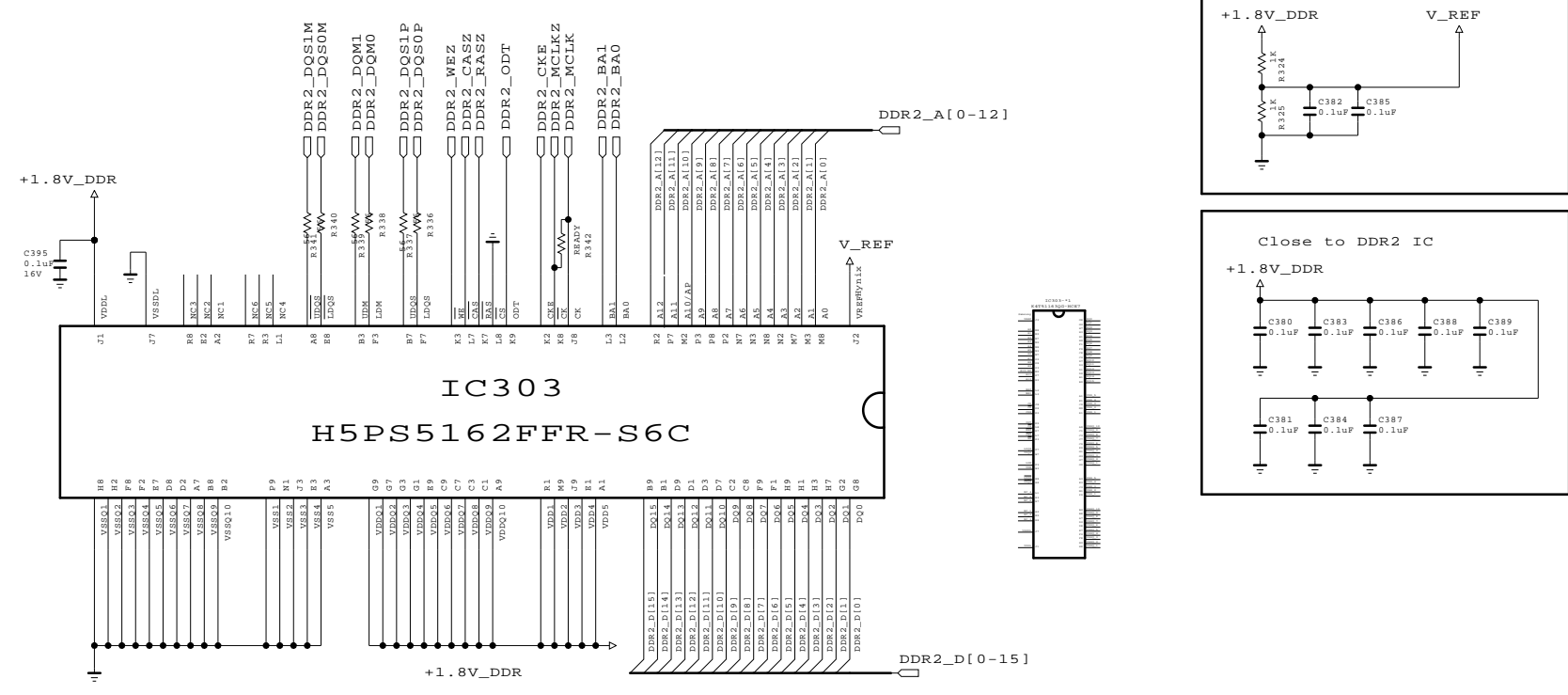

Gain Amp for MNT out

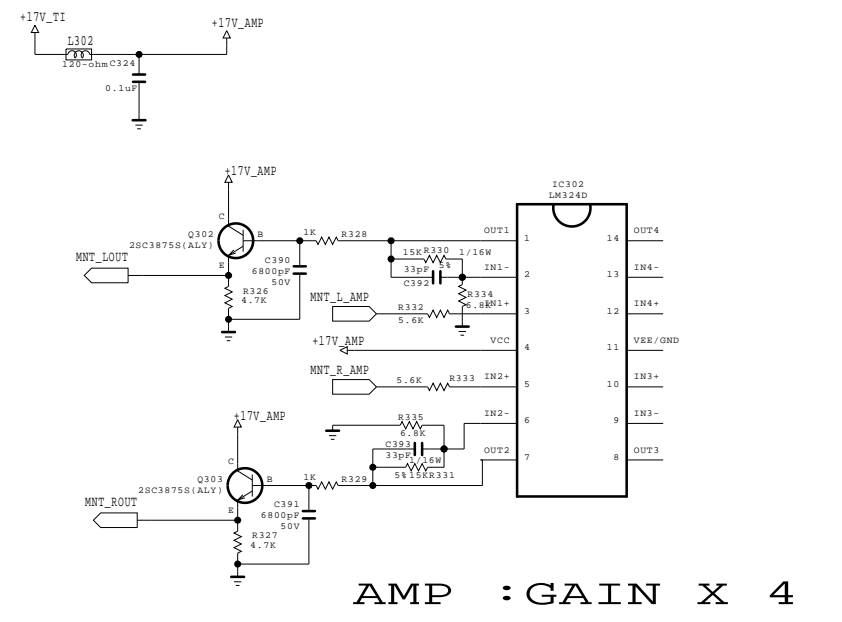

THE Δ SYMBOL MARK OF THIS SCHEMATIC DIAGRAM INCORPORATES SPECIAL FEATURES IMPORTANT FOR PROTECTION FROM X-RADIATION. FILRE AND ELECTRICAL SHOCK HAZARDS, WHEN SERVICING IF IS ESSENTIAL THAT ONLY MANUFACTURERS SPECIFIED PARTS BE USED FOR THE CRITICAL COMPONENTS IN THE Δ SYMBOL MARK OF THE SCHEMATIC.

SECRET
LGElectronics



MODEL	H6RR	DATE	2010/11/1
BLOCK	Tuner/Amp/DDR	SHEET	3 / 4

EAX64103901(BPR) H6 Revolution Circuit Diagram

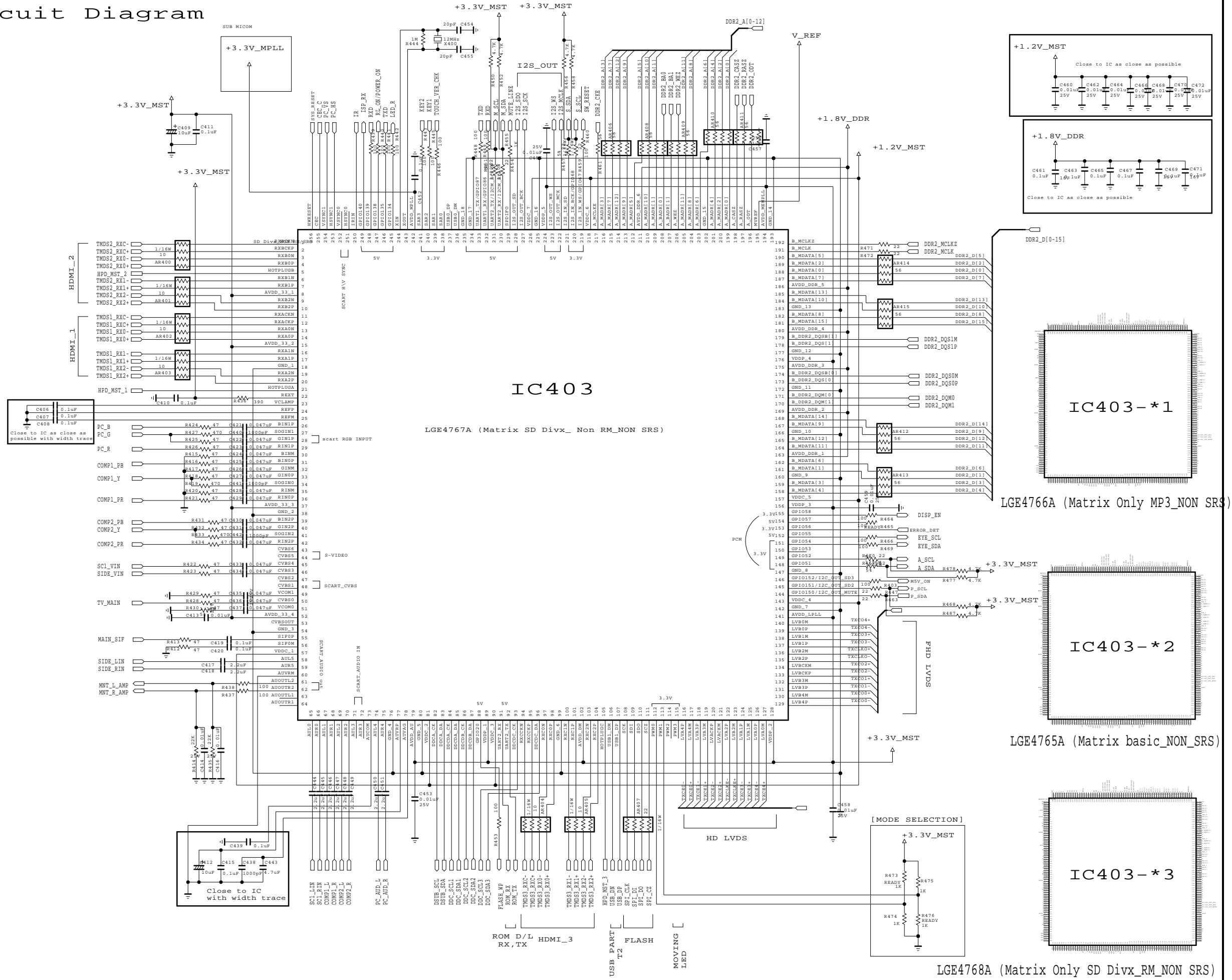
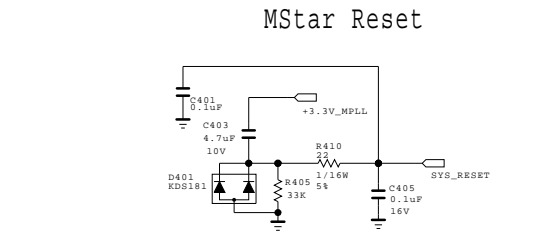
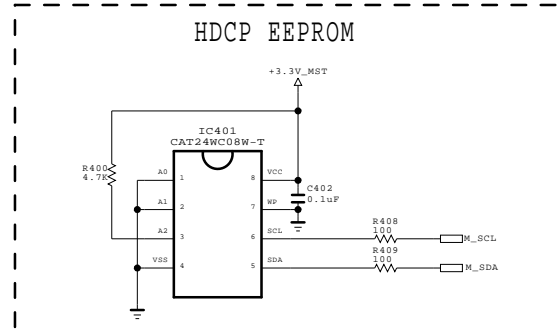
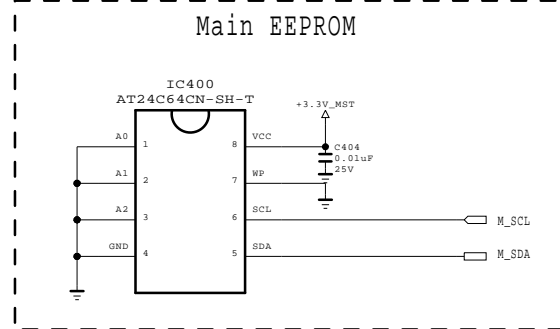
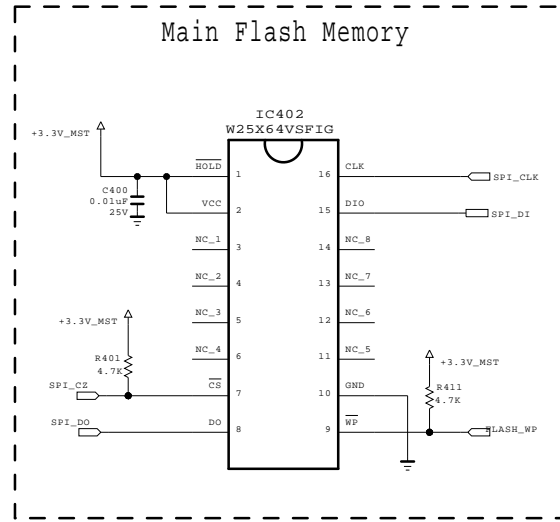

THE Δ SYMBOL MARK OF THIS SCHEMATIC DIAGRAM INCORPORATES SPECIAL FEATURES IMPORTANT FOR PROTECTION FROM X-RADIATION. FILRE AND ELECTRICAL SHOCK HAZARDS, WHEN SERVICING IF IS ESSENTIAL THAT ONLY MANUFACTURERS SPECIFIED PARTS BE USED FOR THE CRITICAL COMPONENTS IN THE Δ SYMBOL MARK OF THE SCHEMATIC.

SECRET
LGElectronics



MODEL	H6RR	DATE	2010/11/1
BLOCK	Main	SHEET	4 / 4



Repair Process

PDP TV	Symptom	A. Picture Problem	Making		
		No Picture/Sound OK	Revision		

First of all, Check whether all of cable between board was inserted properly or not.
(Main B/D ↔ Power B/D, Power B/D ↔ Y-sus B/D, Y-Sus B/D ↔ Z-Sus B/D, LVDS Cable, Speaker Cable, IR B/D Cable,,)

Check Module pattern by using "TILT" key on SVC R/C



<SVC R/C & Pattern>

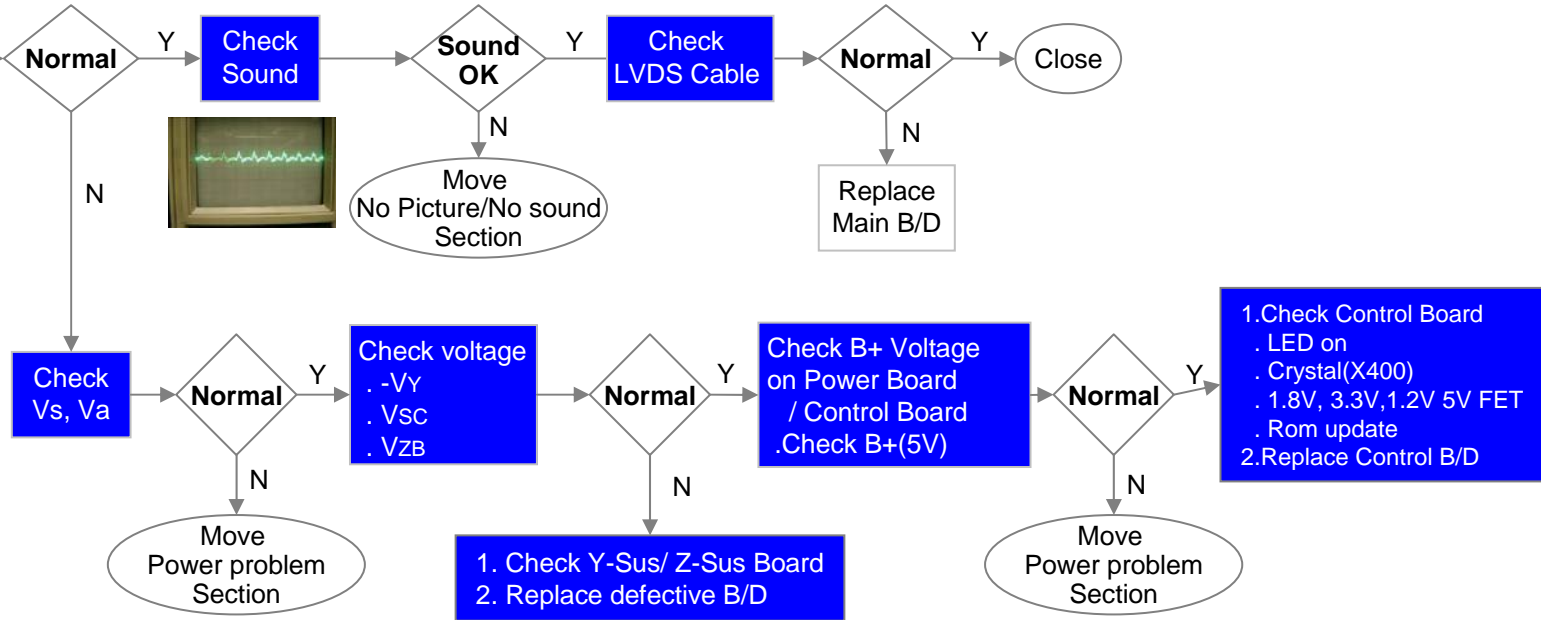

※ Refer to the Module label for each voltage

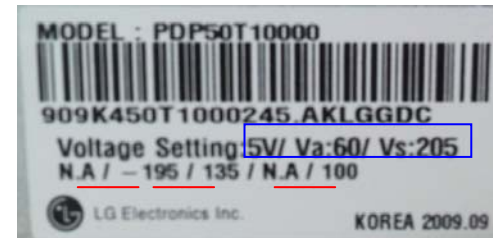
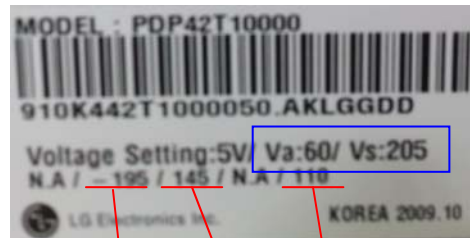

-Vy Vsc VzB

Repair Process

PDP TV	Symptom	A. Picture Problem	Making		
		No Picture/No Sound	Revision		

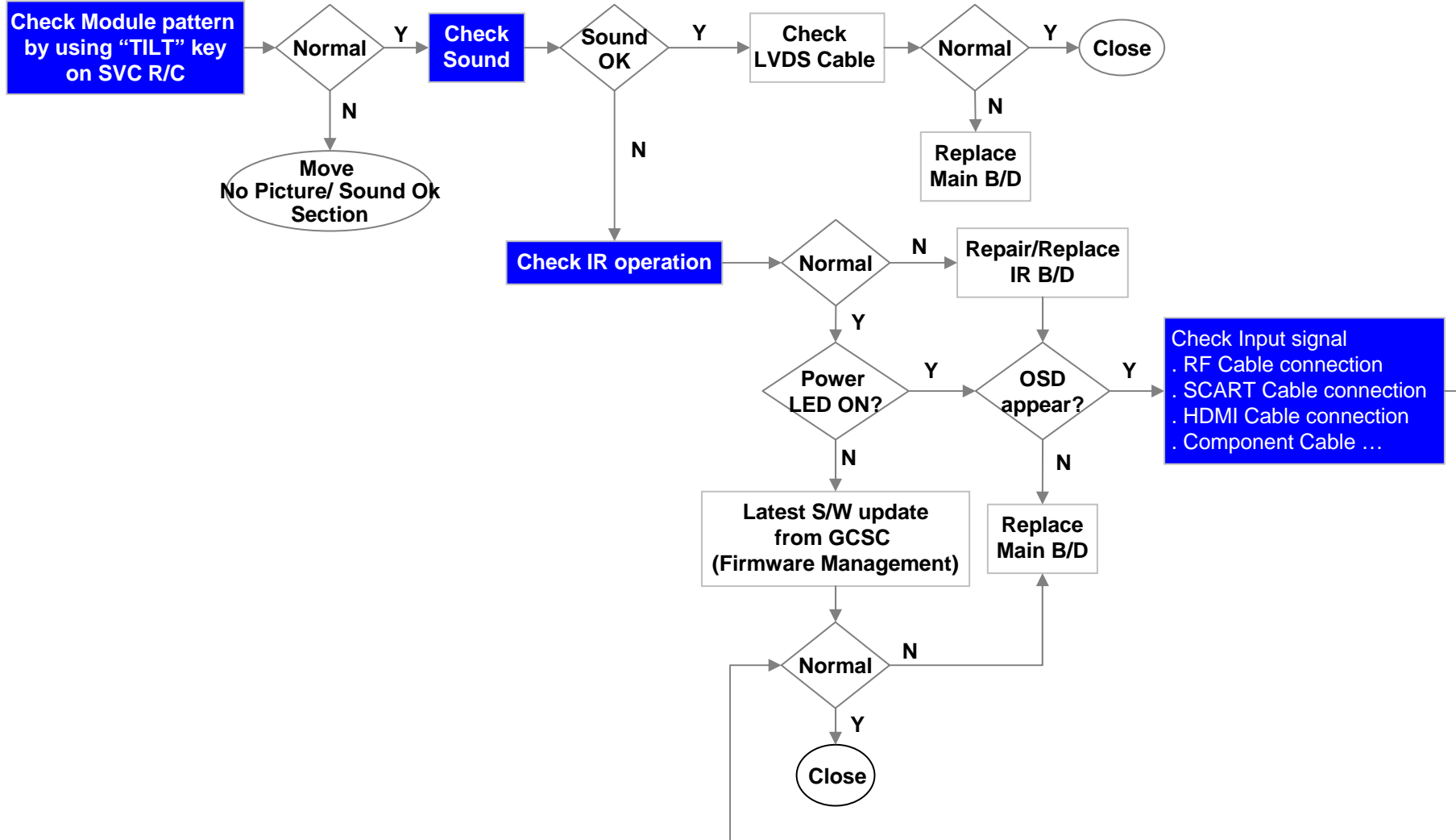

Repair Process

PDP TV	Symptom	A. Picture Problem	Making		
		Mal-discharge/Noise/dark picture	Revision		

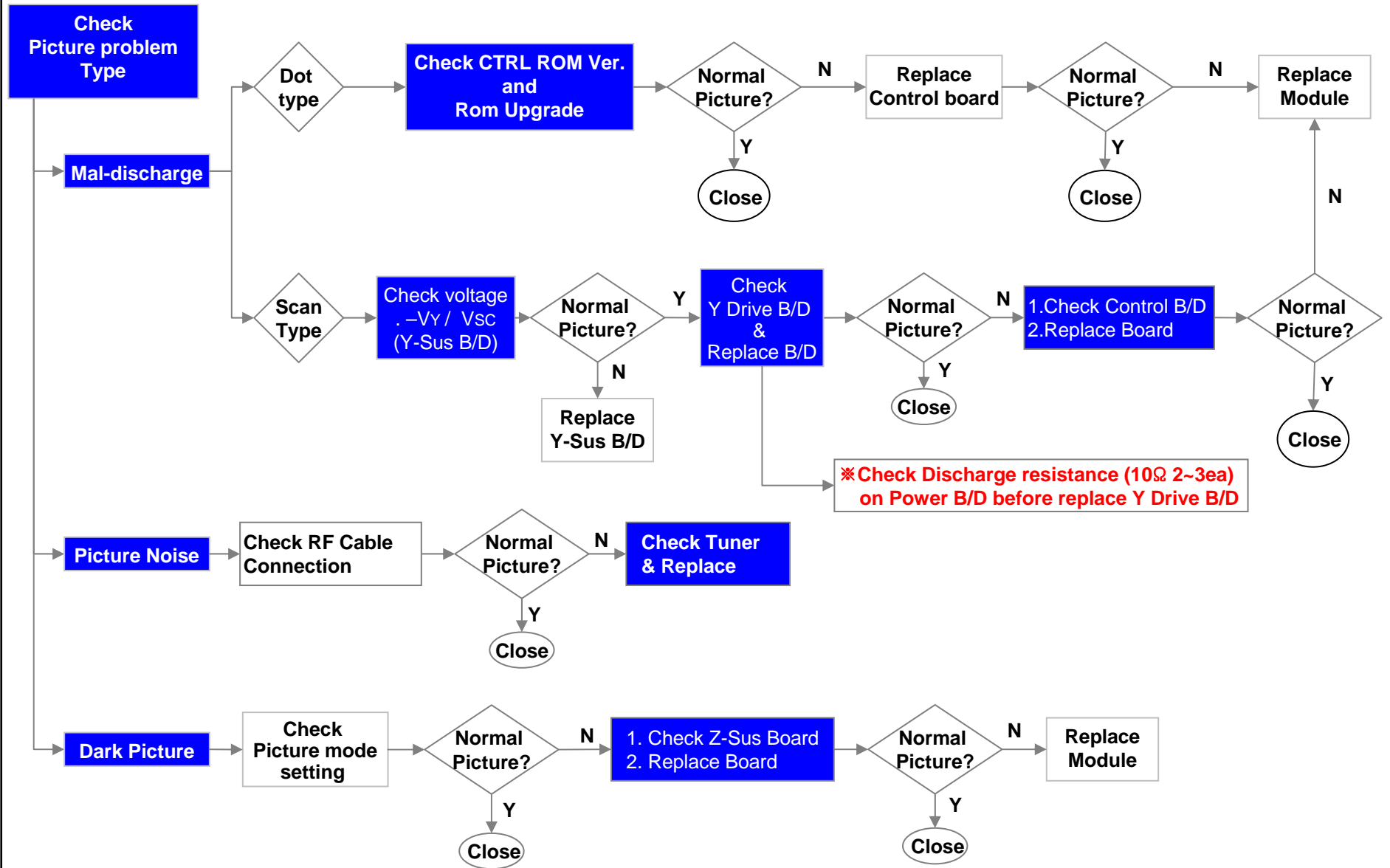

Repair Process

PDP TV	Symptom	A. Picture Problem	Making		
		Picture broken/Freezing	Revision		

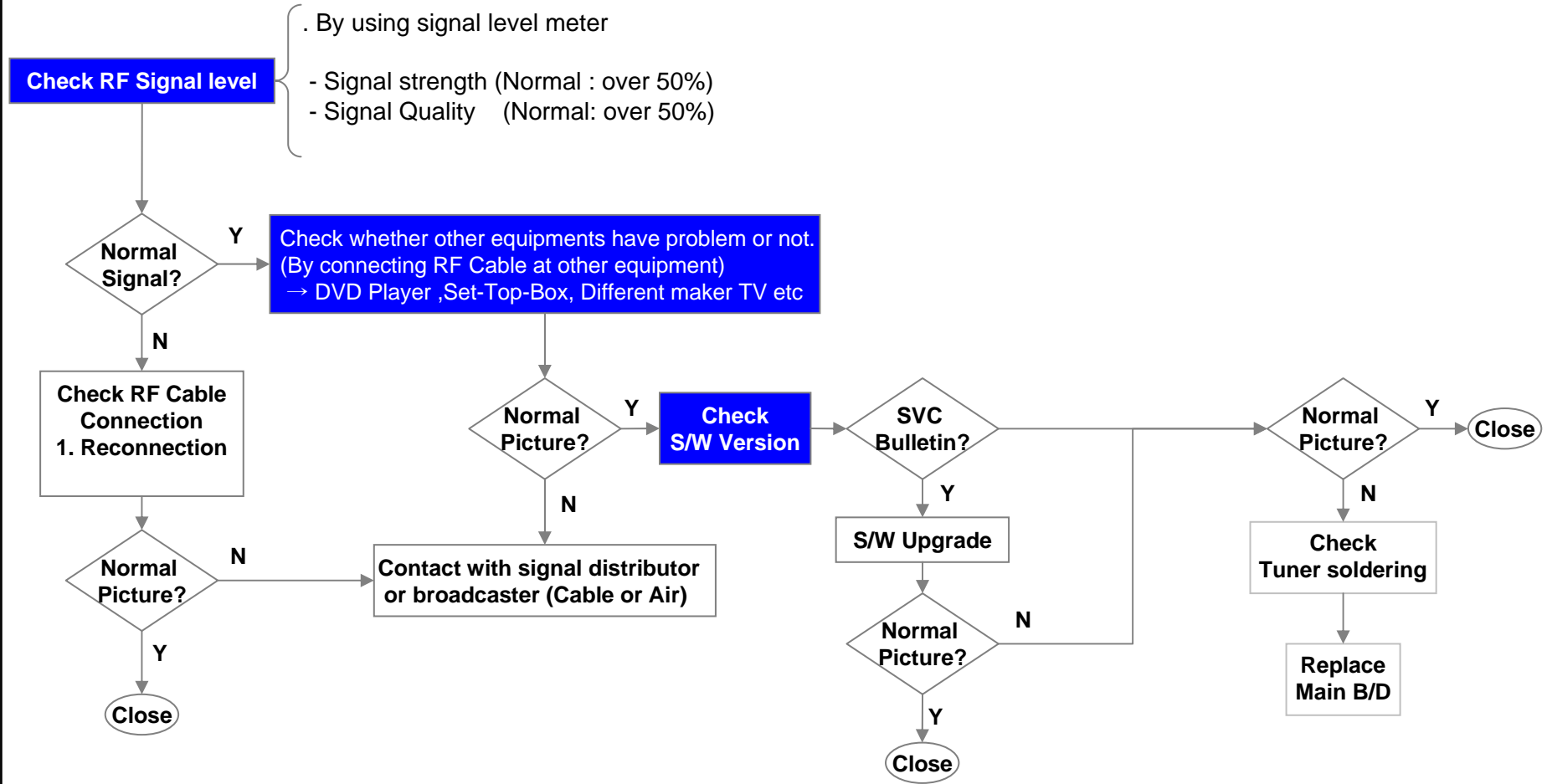

Repair Process

PDP TV	Symptom	A. Picture Problem	Making		
		Vertical bar/ Horizontal Bar	Revision		

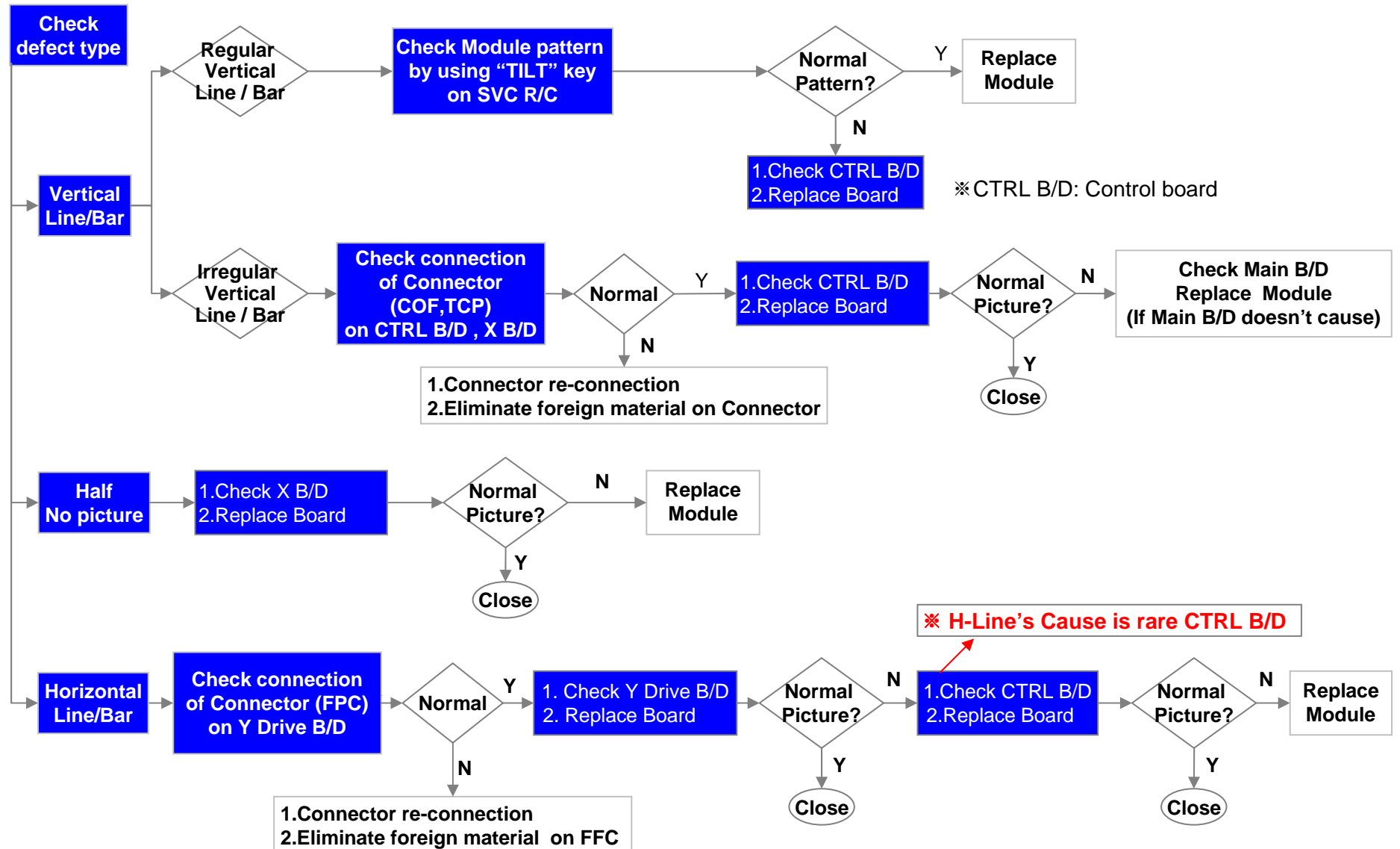

Repair Process

PDP TV	Symptom	B. Power Problem	Making		
		No Power (Not turn on)	Revision		

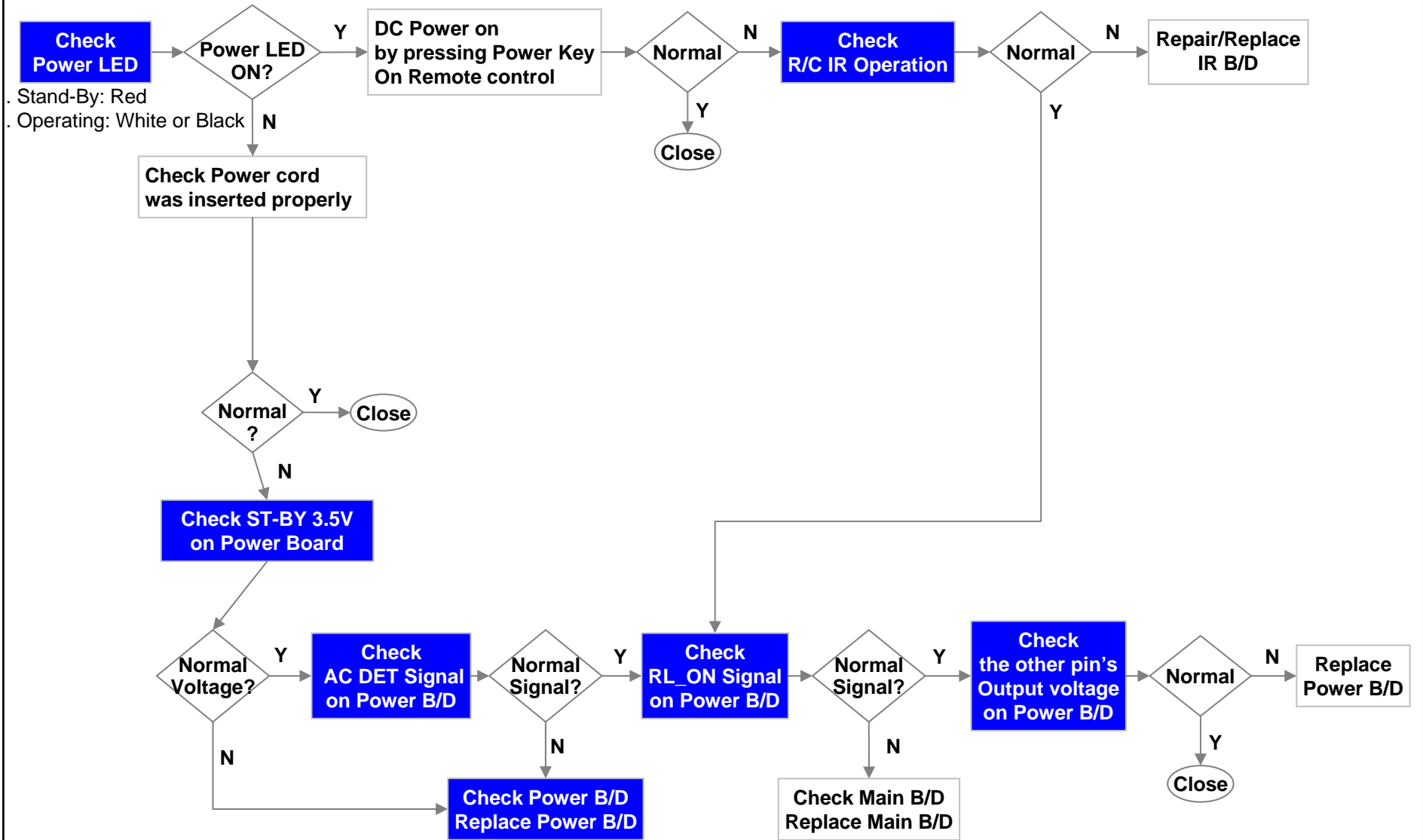

Repair Process

PDP TV	Symptom	B. Power Problem	Making		
		Turn off (Instant, under watching)	Revision		

※ To check Power B/D Protection

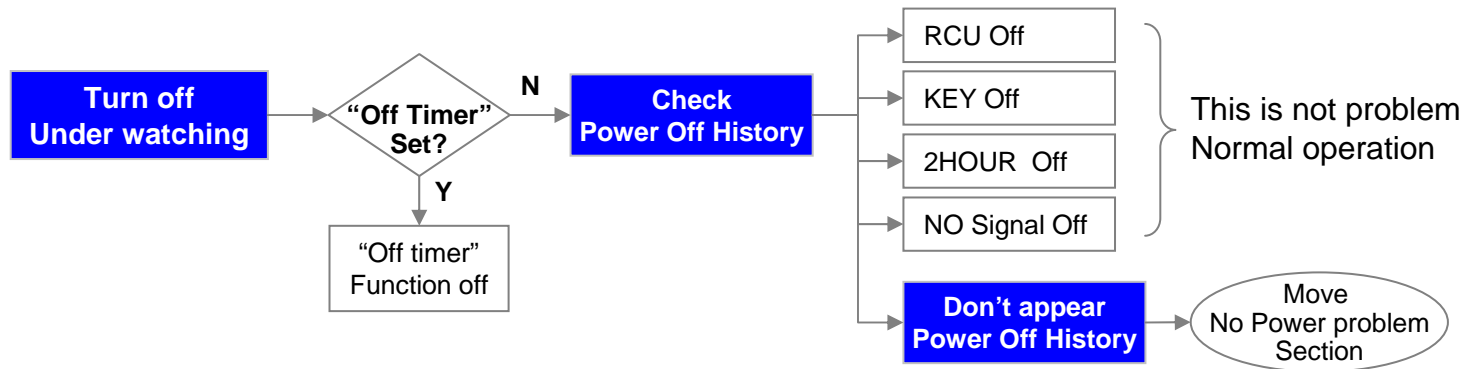
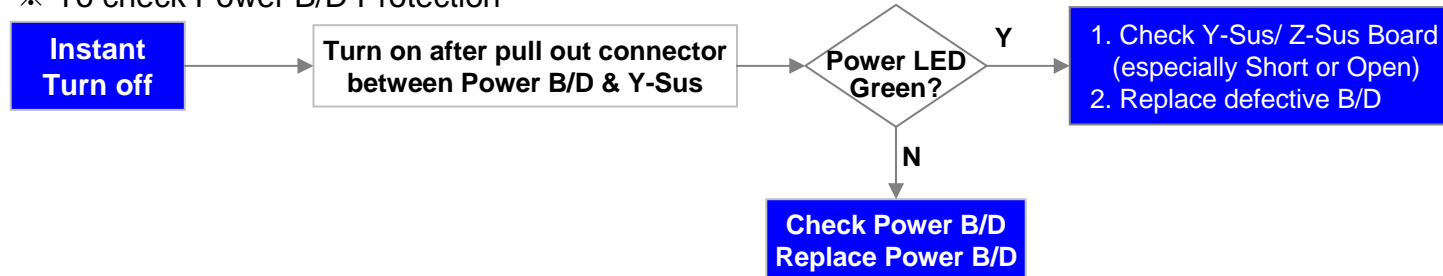

Repair Process

PDP TV	Symptom	C. Sound Problem	Making		
		No sound/ Sound distortion	Revision		

1.No sound(If HDMI Input only have no sound, upload EDID data)

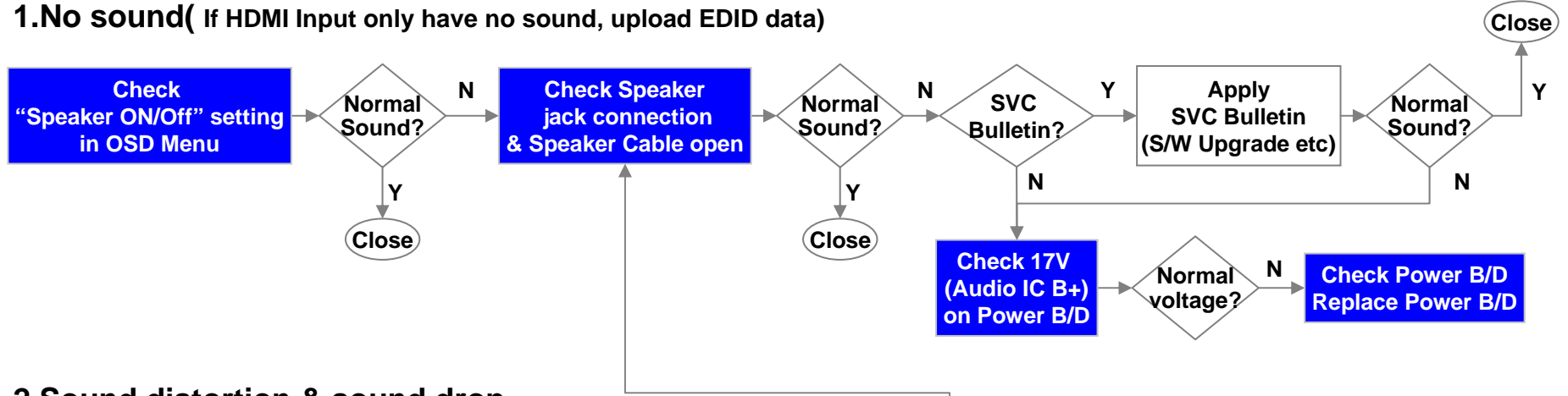

2.Sound distortion & sound drop

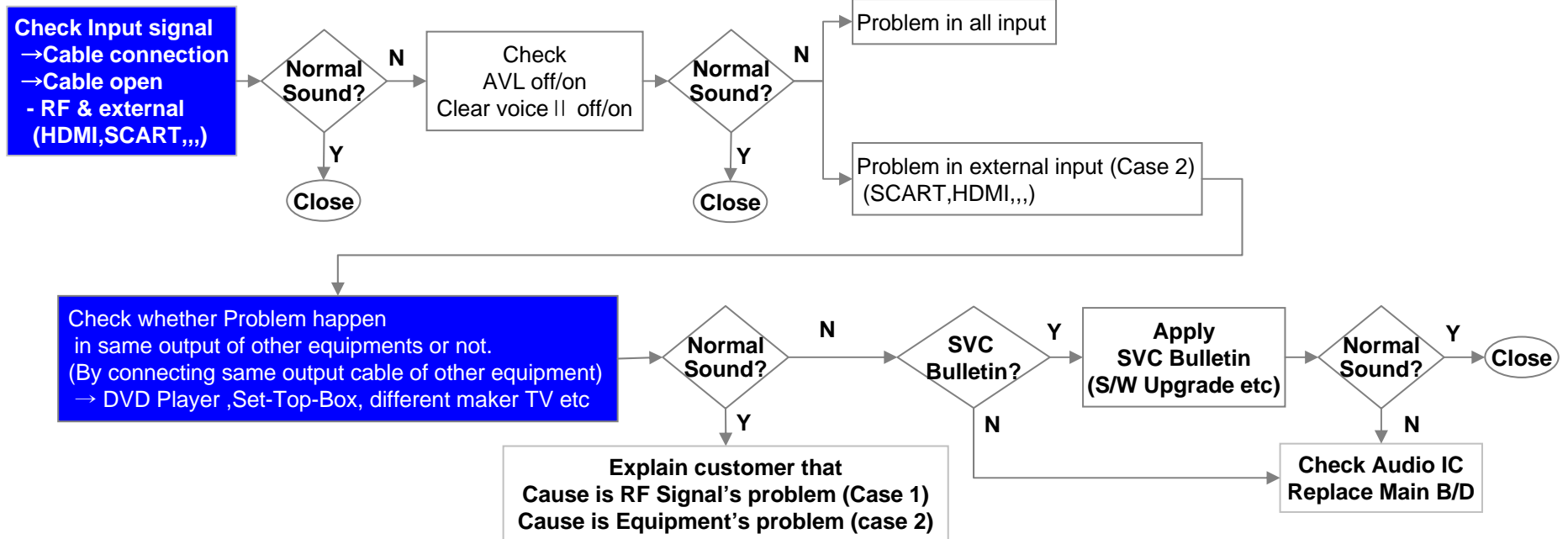

Repair Process

PDP TV	Symptom	D. General Function Problem	Making		
		Remote control	Revision		

1. Remote control (R/C) operating error

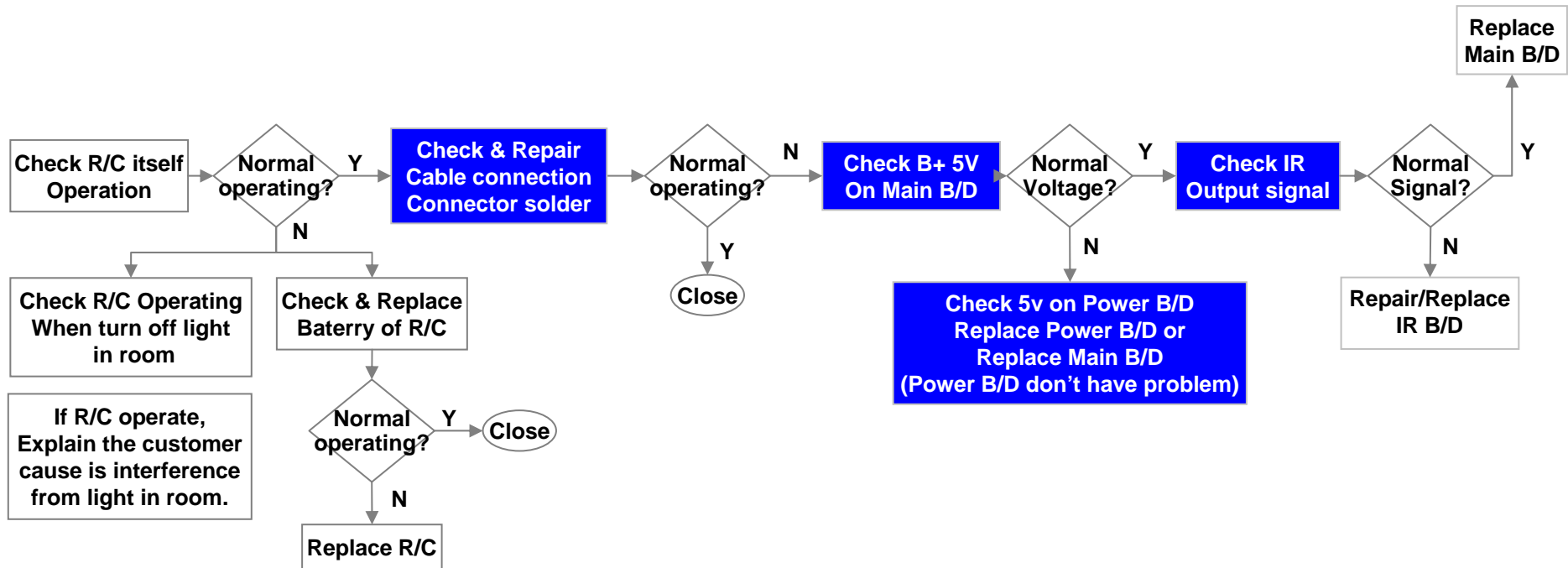

Repair Process-Reference data

PDP TV	Symptom	A. Picture Problem	Making		
	Item	Check Module pattern by Tilt key	Revision		

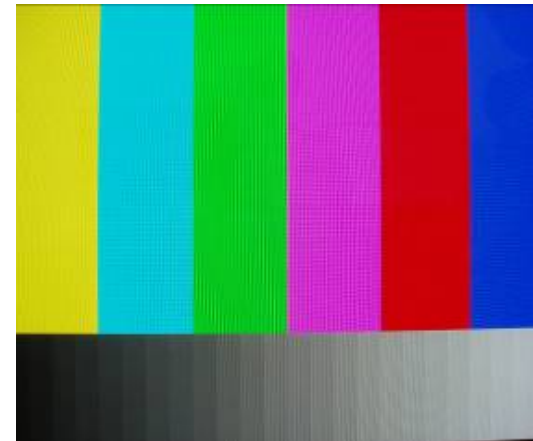
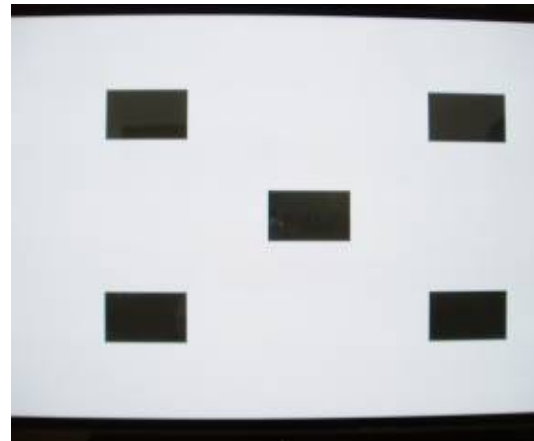

You can see 20 types patterns by using TILT Key on SVC Remote controller (except Old model)
< CHECK Item >

1. Dead pixel 2. Image sticking 3. Mal discharge 4. Module defect (V-Line/Bar, H-Line/Bar,,)
 5. In case of no picture, you can judge defect cause (Module or Main B/D)
- If patterns appear, defect cause is Main B/D

Repair Process-Reference data

PDP TV	Symptom	A. Picture Problem	Making		
		Control Board Checking Method(42G2/50G2)	Revision		

■ Checking Method

- ① Check input voltage(5V of P101) on Control B/D
- ② Check LED On
- ③ If LED light doesn't appear, check Crystal X101 output
- ④ Check 3.3V, 5V, 1.8V FET
- ⑤ Check MCM at VS_DA by using Multi meter

③ Check Crystal(X101)



Check oscillation of Crystal
(Normal: 100 MHz, 1.6v)

⑤ Check MCM



MCM Check point
(+)VS_DA / (-) GND
(Normal: 3.3V)

④ Check Crystal(X101)

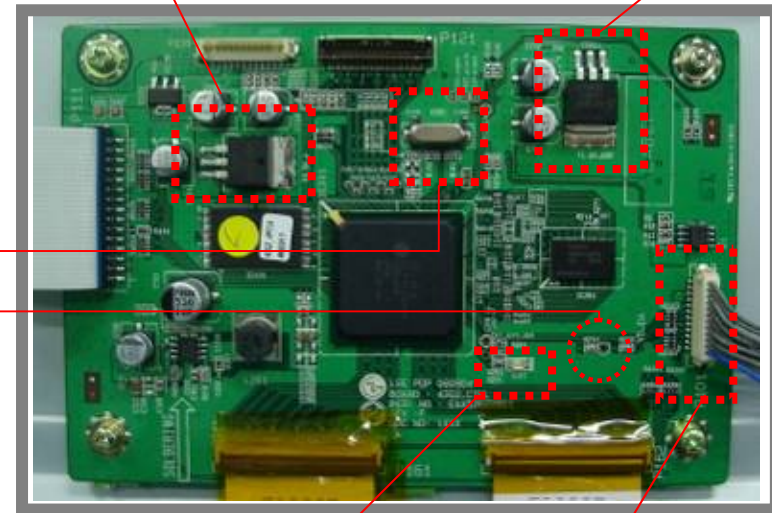
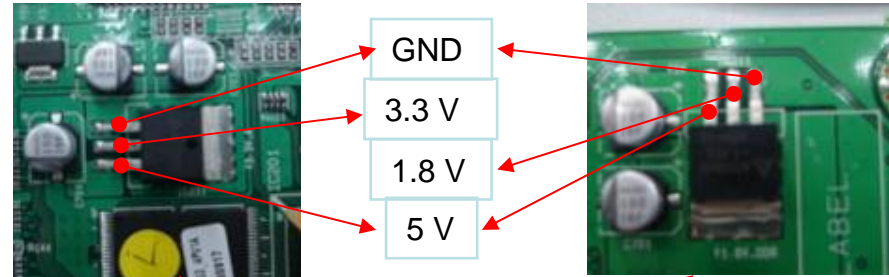

② Check LED On



① Check Input voltage

Repair Process-Reference data

PDP TV	Symptom	A. Picture Problem	Making		
		PDP Module Rom Ver. Checking method	Revision		

■ Check by using Rom Label on control board

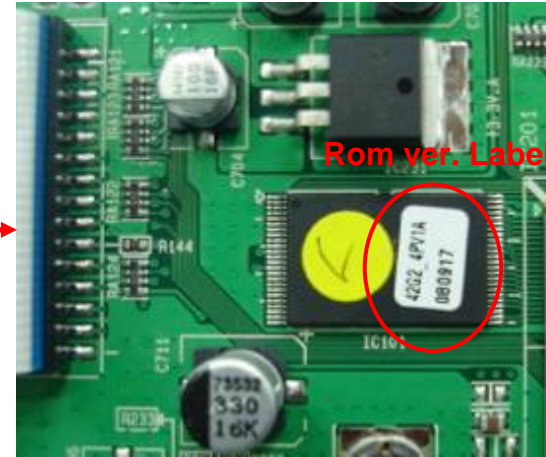
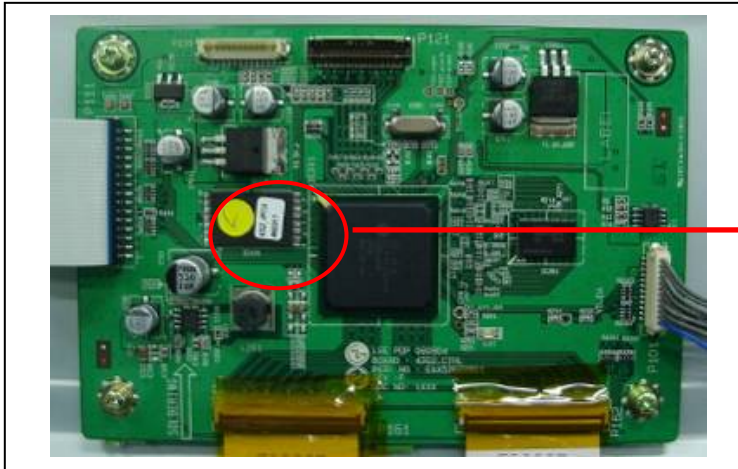

■ Check by using SVC Remocon

Press "In-start" → Press "0000"
 → Select Panel option → Pop up Module Rom ver.

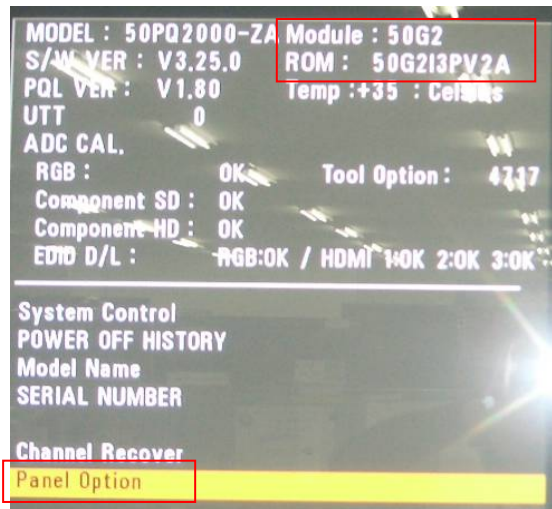

※ Refer to the Module Rom upgrade manual for Rom upgrade.

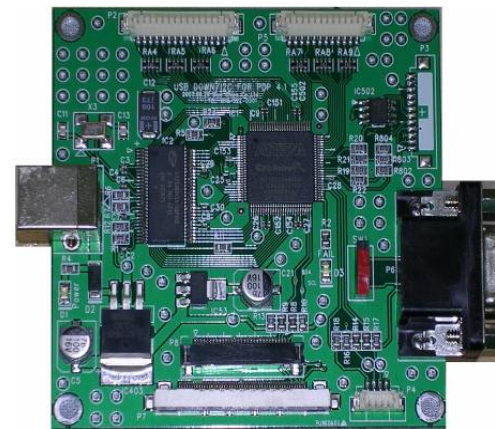



USB Type Jig

Repair Process-Reference data

PDP TV	Symptom	A. Picture Problem	Making		
		Defect type cause by PDP Module	Revision		

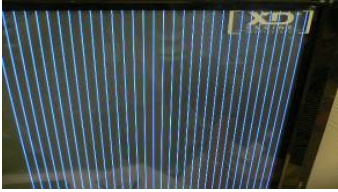
**First of all, Check whether all of cable between board was inserted properly or not.
Next, Check whether there is foreign material on connector.**

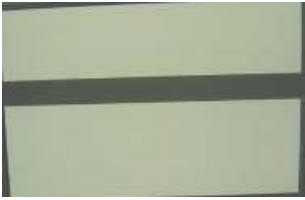
Symptom picture	defects description	To action
	Regular vertical lines	<ol style="list-style-type: none"> 1. Check connection (CTRL B/D, X B/D) 2. Check CTRL B/D 3. Replace CTRL B/D
	Vertical lines or Bar	<ol style="list-style-type: none"> 1. Check connection (CTRL B/D, X B/D) 2. Check CTRL B/D 3. Replace CTRL B/D
	Many irregular vertical lines	<ol style="list-style-type: none"> 1. Check connection (CTRL B/D, X B/D) 2. Check CTRL B/D 3. Replace CTRL B/D
	Horizontal Line or Bar	<ol style="list-style-type: none"> 1. Check connection (Y-Sus B/D ↔ Panel) 2. Check Y-Sus B/D 3. Replace Y-Sus B/D

Repair Process-Reference data

PDP TV	Symptom	A. Picture Problem	Making		
		Connector Type on PDP Module	Revision		

COF Type

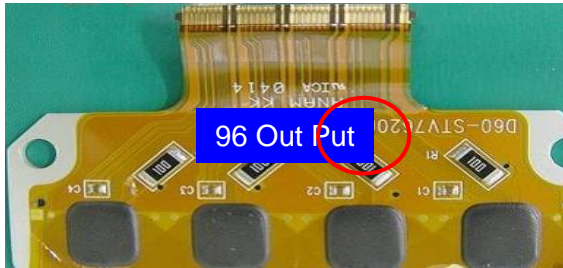

1. Check foreign & Connection status
2. Check bad soldering on Chip resistance

TCP Type

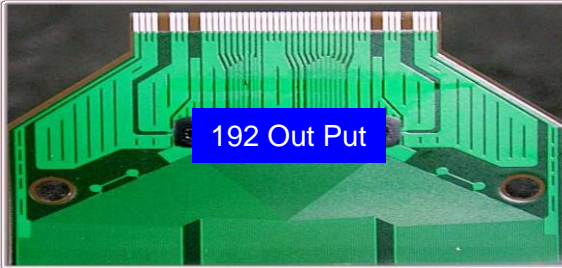

TCP (Tape Carrier Package) is film for IC connect with Electrode pattern (Direct Bonding) on X B/D

FPC Type



Connector to connect between Electrode PAD Of PANEL and Y Drive B/D,Z-Sus B/D

■ Defect symptom



Repair Process-Reference data

PDP TV	Symptom	B. Power Problem	Making		
		Check voltage on Power board	Revision		

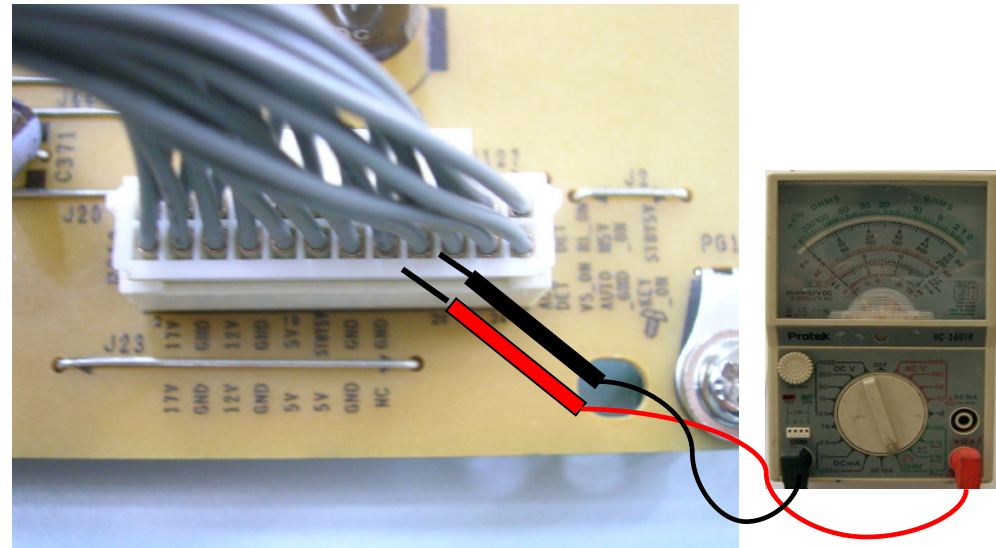
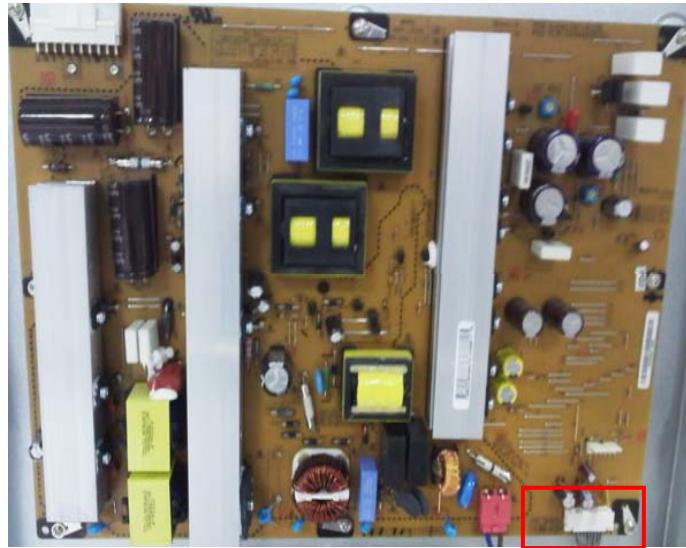

Pin Map
Power B/D ↔ Main B/D
(P813) (P1100)

P814			
1	17V	2	17V
3	GND	4	GND
5	5V	6	5V
7	5V	8	Error_DET
9	GND	10	GND
11	GND	12	GND
13	STBY	14	STBY
15	RL_ON	16	AC_DET
17	M_ON	18	AUTO_GND
Wafer	SMAW200-H18S2		

Checking Order

No.	Checking Point	Spec	Remark
14	STBY 5V	5V	
16	AC DET	High(3.3V~5V)	
8	Error_DET	5V	
15	RL_ON	High(3.3V~5V)	
17	M5_ON	High(3.3V~5V)	
6	Vs-ON	High(3.3V~5V)	
7	Check the other pin's output		